

DeltaV™ Flex.Connect Solutions for Siemens® Moore APACS+ & QUADLOG I/O

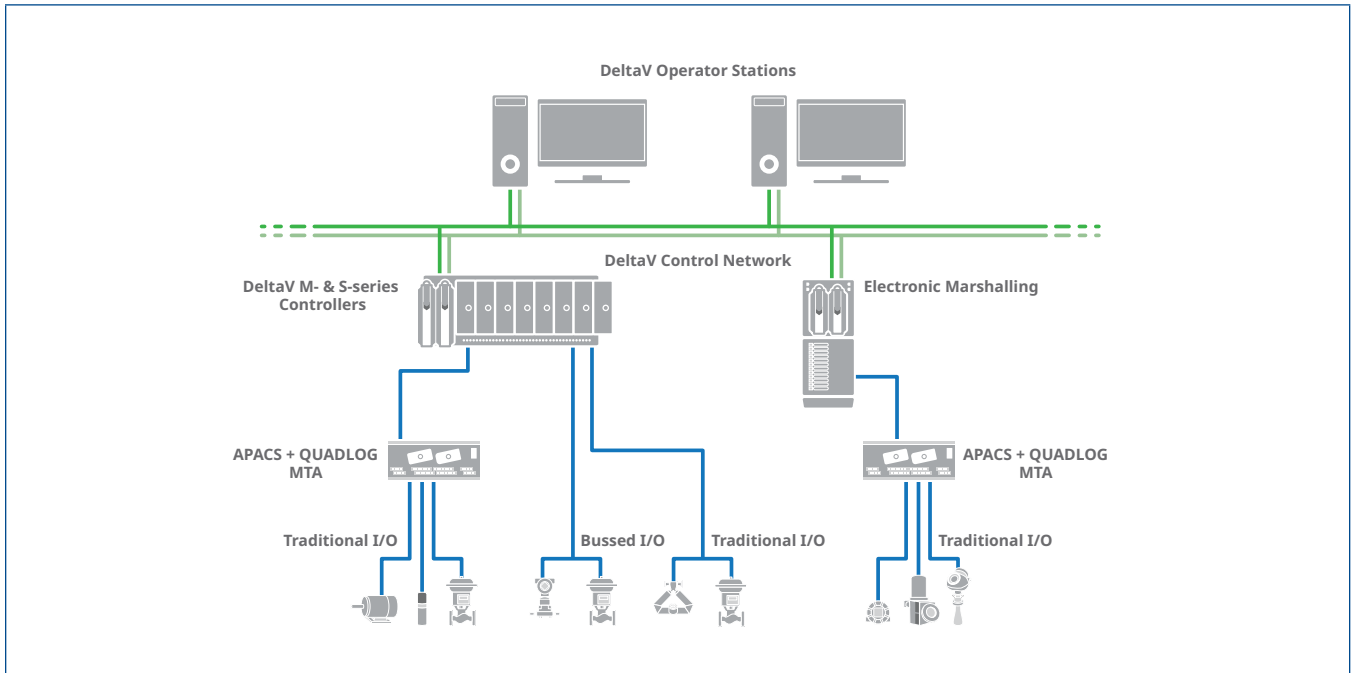

DeltaV™ Flex.Connect wiring solutions protect your wiring investment as you convert from APACS+ & QUADLOG to the DeltaV System.

- Reduce business risks by minimizing process downtime
- Save on installation costs
- Preserve HART® signals

Introduction

If concerns about downtime and wiring costs are preventing you from migrating your Siemens® Moore APACS+ & QUADLOG system to a new DeltaV™ system, then consider DeltaV Flex.Connect wiring solutions for APACS+ & QUADLOG I/O.

Benefits

Reduce business risks by minimizing process downtime.

This solution brings device signals to DeltaV I/O from existing APACS+ & QUADLOG I/O marshalling termination assemblies. Keeping device wires intact accelerates the new system startup, enabling you to rapidly resume production.

Save on installation costs. Eliminating new field wiring saves money and reduces the risk of errors. Time and materials savings are significant.

Preserve HART signals. Use HART® Pass-through for complete diagnostics at the DeltaV Operator Station.

Wiring Options

There are two options available for a cold cutover of the Siemens Moore APACS+ & QUADLOG I/O. Both of these solutions can be pre-wired to the DeltaV I/O terminal blocks and tested before the installation takes place.

Option #1: (Cables Only)

DeltaV Flex.Connect wiring solutions provide a direct connection from the Siemens Moore APACS+ & QUADLOG I/O marshalling termination assemblies (MTA) to the DeltaV CHARM terminal blocks and traditional I/O cards. Only the existing MTA is left in place for this solution. APACS+ & QUADLOG I/O marshalling termination assemblies have many different I/O types. Passive marshalling termination assemblies have been selected for the DeltaV Flex.Connect wiring solutions noted below. These are mostly cable only solutions with no signal conditioning requirements. There are twisted-pair cables available for analog I/O signals and straight-through cables available for discrete I/O signal applications.



Option #2: (Cables and Interface Adaptor Panels)

DeltaV Flex.Connect wiring solutions provide a direct connection from the Siemens Moore APACS+ & QUADLOG I/O marshalling termination assemblies (MTA) existing I/O cable in the MODULRAC to the DeltaV CHARM terminal blocks and traditional I/O cards. The existing MTA and I/O cable and MODULRAC (I/O card cage is removed) are left in place for this solution. APACS+ & QUADLOG I/O marshalling termination assemblies have many different I/O types. Passive marshalling termination assemblies have been selected for the DeltaV Flex.Connect wiring solutions noted below. These are mostly cable only solutions with no signal conditioning requirements. All cables for this option are twisted-pair.

Also, with this option, if there is enough depth in the cabinet, the new DeltaV Controller(s), power supply(s), 4 & 8-wide I/O carriers with I/O cards and terminal blocks can be installed on a special adaptor rack overtop the interface adaptors and I/O cables. This adaptor rack is bolted into the same location as the MODULRAC I/O card cage and also features a swing-down option where the DeltaV can be moved down to allow the maintenance staff to access the cables and interface adaptor panels.



Option #1: Product Description and Specifications

The Siemens Moore APACS+ & QUADLOG I/O marshalling termination assemblies (MTA) are left in place for this solution. There are twisted-pair cables available for analog I/O signals and straight-through cables available for discrete I/O signals.

Note: For the SAM/HFM MTAs, signal isolators are required for the AI signals, in addition to the cable solutions, due to the commoning of all the device field signal negatives.

Enhanced Analog Module (EAM)

Sixteen Analog Inputs or Analog Outputs or Discrete Inputs or Discrete Outputs connect to sixteen DeltaV AI/AO/DI/DO CHARMS – marshalling termination assembly model number 16190-1.

Resistance Temperature Module (RTM)

Sixteen RTD 3-wire Analog Inputs connect to sixteen DeltaV RTD CHARMS – marshalling termination assembly model number 16210-1.

Standard Analog Module (SAM)

Thirty-two Analog Inputs or Analog Outputs or Discrete Inputs or Discrete Outputs connect to thirty-two DeltaV AI/AO/DI/DO CHARMS – marshalling termination assembly model number 16160-x.

Option #2: Product Description and Specifications

The Siemens Moore APACS+ & QUADLOG I/O marshalling termination assemblies (MTA) and I/O cables are left in place for this solution. One common passive interface adaptor is available for connecting to the existing I/O cable in the back of the MODULRAC. There is an option available for mounting the new DeltaV system overtop the interface adaptors and I/O cables. For this option, all the cables are all twisted-pair.

Note: For the SAM/HFM MTAs, signal isolators are required for the AI signals, in addition to the cable and interface adaptors solutions, due to the commoning of all the device field signal negatives.

HART Fieldbus Module (HFM)

Sixteen Analog Inputs connect to sixteen DeltaV 4-20mA HART CHARMS – marshalling termination assembly model numbers 16191-1 and -21.

Voltage Input Module (VIM)

Sixteen*Thermocouple/mV Analog Inputs connect to sixteen DeltaV Thermocouple/mV CHARMS – marshalling termination assembly model number 16210-1.

Note: *Emerson recommends re-wiring Thermocouple signals directly to DeltaV AI-T/C solutions.

Input Discrete Module (IDM)

Thirty-two Contact Sense Discrete Inputs connect to thirty-two DeltaV DI 120 VAC Plus Isolated or 230 VAC Isolated CHARMS – marshalling termination assembly model numbers 16193-1 and -21.

Output Discrete Module (ODM)

Thirty-two Discrete Outputs connect to thirty-two DeltaV DO Isolated VAC CHARMS – marshalling termination assembly model numbers 16192-1 and -21.

Standard Discrete Module (SDM)

Thirty-two 24 VDC Discrete Inputs and Outputs connect to thirty-two DeltaV 24 VDC Isolated DI or DO CHARMS – marshalling termination assembly model number 16167-1.

Option #1: Ordering Information

For inquiries and ordering information, please contact your local Emerson sales office. Please specify the required cable lengths on your request. DeltaV Flex.Connect solutions for specific APACS+ / QUADLOG Marshalling Termination Assemblies (MTA) models are indicated in the following table:

(Note: DeltaV Flex.Connect solutions drawings are available upon request.)

Flex.Connect Solution #	APACS+ & QUADLOG MTA Types	APACS+ & QUADLOG MTA Signals	DeltaV™ CHARM Types	Flex.Connect Wiring Solutions Drawing Numbers
FC-S1-CBL-3-80	EAM-16190-1	16 AI / AO / DI / DO	AI 4-20mA, HART DI / DO 24 VDC	FC-S1-EAM
FC-S1-CBL-1-40	RTM-16210-1	16 AI (RTD) 3-wire	16 - RTD	FC-S1-RTM
FC-S1-CBL-4-80	SAM-16160-x (1)	32 AI / AO / DI / DO	AI / AO 4-20 mA , HART DI / DO 24 VDC	FC-S1-SAM
FC-S1-CBL-1-10	HFM-16191-2 & -21 (1)	16 AI	16 - AI 4-20 mA HART	FC-S1-HFM
FC-S1-CBL-1-30	VIM-16170-1	16 AI (*TC/mV)	16 - TC/mV	FC-S1-VIM
FC-S1-CBL-2-50	IDM-16193-1 & -21	32 DI 115/230 VAC	32 - DI 115/230 VAC Isolated	FC-S1-IDM
FC-S1-CBL-2-60	ODM-16192-1 & -21	32 DO 115/230 VAC	32 - DO VAC Isolated	FC-S1-ODM
FC-S1-CBL-2-70	SDM-16167-1	32 DI/DO 24 VDC	32 - 24 VDC Isolated DI/DO	FC-S1-SDM

(1) For these Siemens Moore APACS+ & QUADLOG I/O types, contact your local Emerson sales office to discuss solution options.

Note: *Emerson recommends re-wiring Thermocouple signals directly to DeltaV AI-T/C solutions.

Option #2: Ordering Information

For inquiries and ordering information, please contact your local Emerson sales office. Please specify the required cable lengths and the quantity of required interface & rack adaptors on your request. DeltaV Flex.Connect solutions for specific APACS+ / QUADLOG Marshalling Termination Assemblies (MTA) models are indicated below:

- Enhanced Analog Module (EAM) – P/N 16190-1
- Resistance Temperature Module (RTM) – P/N 16210-1
- Standard Analog Module (SAM) – P/N 16160-x
- HART Fieldbus Module (HFM) – P/Ns 16191-2 & -21
- Voltage Input Module (VIM) – P/N 16170-1
- Input Discrete Module (IDM) – P/Ns 16193-1 & -21
- Output Discrete Module (ODM) – P/Ns 16192-1 & -21
- Standard Discrete Module (SDM) – P/N 16167-1

Prerequisites

A preliminary site visit is required to survey installed control system architecture and electrical grounding practices, to document I/O models and numbers of each, and to review schedule constraints and turnaround objectives. Qualified Emerson engineers or technicians perform site reviews.

Services

For help in planning, justifying, or implementing your system migration, contact your local Emerson representative. Expert consultants are available to advise you on a variety of concerns, including safety system design, implementation and standards compliance, digital buses, wireless applications, control performance, and process optimization.

©2024, Emerson. All rights reserved.

The Emerson logo is a trademark and service mark of Emerson Electric Co. The DeltaV logo is a mark of one of the Emerson family of companies. All other marks are the property of their respective owners.

The contents of this publication are presented for informational purposes only, and while diligent efforts were made to ensure their accuracy, they are not to be construed as warranties or guarantees, express or implied, regarding the products or services described herein or their use or applicability. All sales are governed by our terms and conditions, which are available on request. We reserve the right to modify or improve the designs or specifications of our products at any time without notice.

Contact Us

 www.emerson.com/contactus