

# Rosemount™ 2460 System Hub

## for tank gauging systems



### Transfers tank gauging data to Rosemount TankMaster™, Host and DCS systems

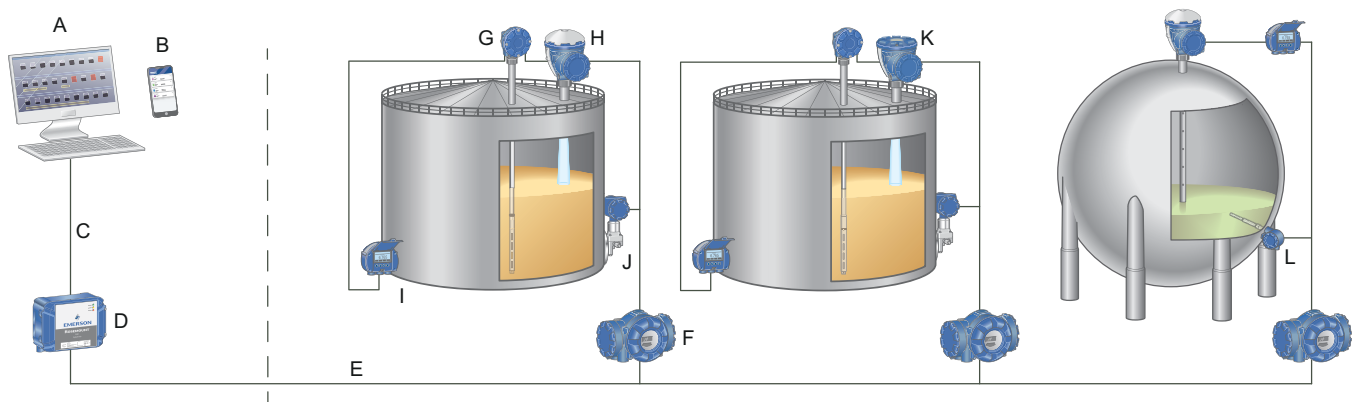
- Ensure fast data update rate
- Serves up to 64 tanks
- Benefit from scalable options for all system sizes
- Get real-time inventory calculations with API standard net volumes
- Get flexible and configurable multiple port connectivity
- Achieve instrument and system redundancy
- Enable other vendor emulation by bringing in data from gauges such as Enraf®, Varec®, and Sakura

# Efficient update of vital online tank data

The Rosemount 2460 System Hub is a data concentrator that continuously polls and stores data from field devices such as radar level gauges, pressure and temperature devices. Measured and calculated data from one or more tanks is communicated via the Rosemount 2410 Tank Hub to the system hub buffer memory. Whenever a request is received, the system hub can immediately send data from a group of tanks to a TankMaster PC or a host.

The system hub also supports connection of other tank gauging instruments such as TankRadar™ Pro and TankRadar Rex gauges. In addition, it can be used to connect devices from other vendors, such as Honeywell® Enraf, Whessoe, etc.

**Figure 1: Tank Gauging System Overview**



- A. Rosemount TankMaster Inventory Management
- B. Rosemount TankMaster Mobile Inventory Management
- C. Modbus® RTU/TCP
- D. Rosemount 2460 System Hub
- E. Tankbus
- F. Rosemount 2410 Tank Hub
- G. Rosemount 2240S Multi-input Temperature Transmitter with Rosemount 765 Multiple Spot Temperature and Water Level Sensor
- H. Rosemount 5900S Radar Level Gauge
- I. Rosemount 2230 Graphical Field Display
- J. Rosemount 3051S Pressure Transmitter
- K. Rosemount 5900C Radar Level Gauge
- L. Rosemount 644 Temperature Transmitter with Rosemount 65, 114C, or 214C Single Point Temperature Sensor

## Contents

Efficient update of vital online tank data.....	2
Ordering information.....	6
Specifications.....	14
Product certifications.....	20
Dimensional drawings.....	21

## Configurable multiple port connectivity

The Rosemount 2460 has eight slots for communication interface boards. These boards can be individually configured for communication with hosts or field devices. The Rosemount 2460 supports a number of host communication interface standards such as Ethernet, TRL2, RS485, and RS232. For field communication TRL2 and RS485 are supported, as well as other standards such as Enraf BPM and Digital Current Loop (Whessoe).

## Modbus TCP communication to host

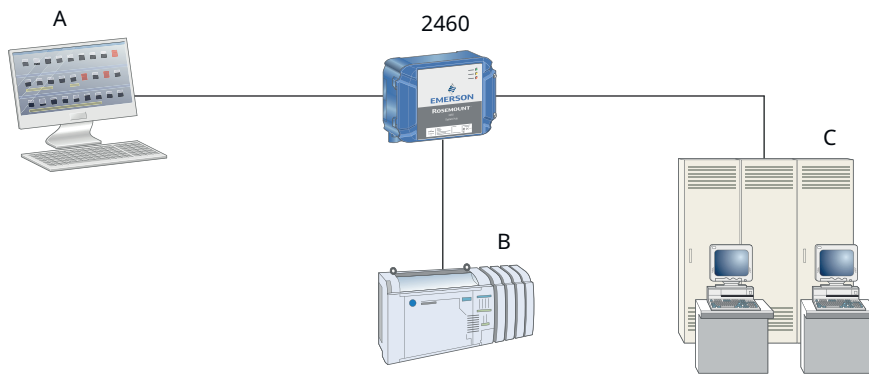
One of the system hub's three Ethernet ports is used for Modbus TCP connection to host systems. By simply connecting the system hub to the existing LAN network, communication over Ethernet is established:

- Easy access, no special converters required
- Fast communication
- No need for dedicated cabling
- Can be connected to TankMaster or other hosts

## User-defined Modbus mapping

The Rosemount 2460 can easily be integrated into existing hosts as it can be configured to match the existing value mapping of the current system. It provides flexibility when replacing legacy devices as it can be set up to match the old device without configuring the host system.

**Figure 2: User-Defined Modbus Mapping**



- A. TankMaster PC<sup>(1)</sup>
- B. Rosemount 2460 System Hub
- C. Existing legacy HMI<sup>(2)</sup>
- D. Existing DCS<sup>(2)</sup>

(1) Standard connection to Rosemount 2460.

(2) User-defined Modbus mapping set-up to match the configuration of the legacy data collector.

## Improved system reliability with redundancy

The system hub can provide redundancy for critical operations by using two identical devices.

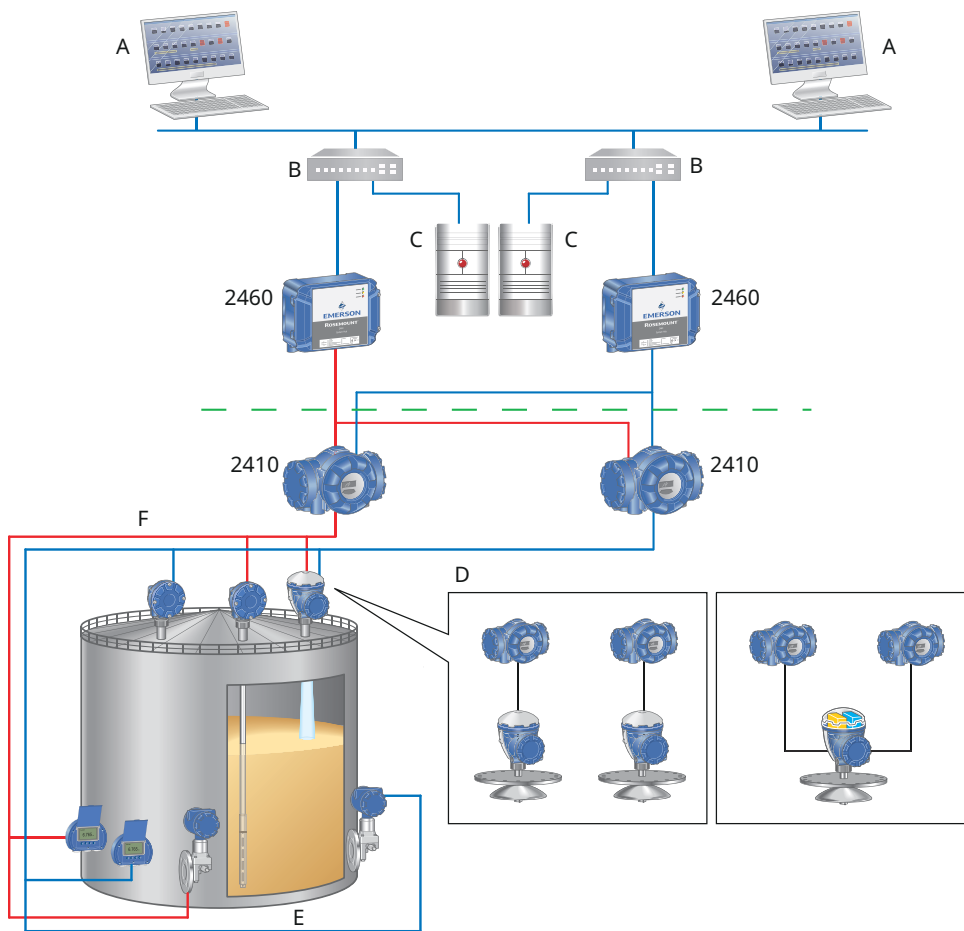
The primary system hub is in active mode and the other one is in passive mode. If the primary unit stops working properly the secondary unit is activated and a failure message is sent to TankMaster (or a DCS system).

Redundancy can be utilized for some or all equipment in the system from the control room to the field devices.

Redundancy is supported on field level as well by using two field devices connected to the same tank for hot redundancy of field values. It can be a Rosemount 5900 2-in-1, two separate Rosemount 5900 devices, or two separate devices of different types.

Field port redundancy is supported where two field ports can be connected in a ring network where one acts as a hot backup. All field ports are available for redundancy. It is also possible to use redundancy individually on ports 1-2, ports 3-4, or ports 5-6.

**Figure 3: Fully Redundant System**



- A. TankMaster client PCs
- B. Network switches
- C. TankMaster servers
- D. Alternatives for level redundancy:  
  - Two tank hubs and two Rosemount 5900S/5300/5408 Level Gauges
  - Two tank hubs and one Rosemount 5900S, 2-in-1 Level Gauges
- E. Pressure x 2
- F. Temperature x 2

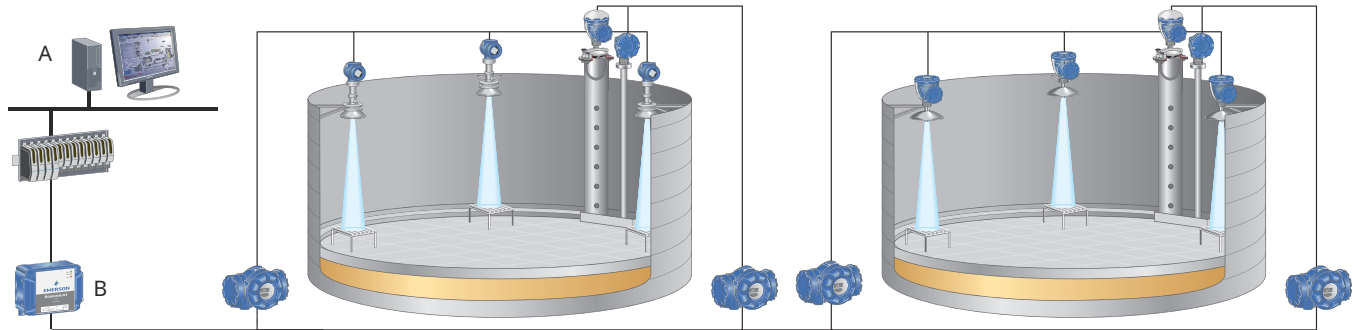
## Continuous automatic monitoring of floating roofs

The Rosemount 2460 monitors the condition of the floating tank roof to prevent the risk of a hazardous condition. The floating roof monitoring function in the system hub includes:

- Roof tilt detection
- Buoyancy calculations
- Status alerts

The system hub supports up to three shell-mounted tilt gauges at top of the tank with/without level reference gauges.

**Figure 4: Floating Roof System with Shell Mounted Radar Devices**



- A. DCS/Host
- B. Rosemount 2460 System Hub

The floating roof monitoring can easily be integrated to the current system at site, by connecting the system hub to the Modbus server and poll the system hub's input registers.

## Seamless integration of gauges from other vendors

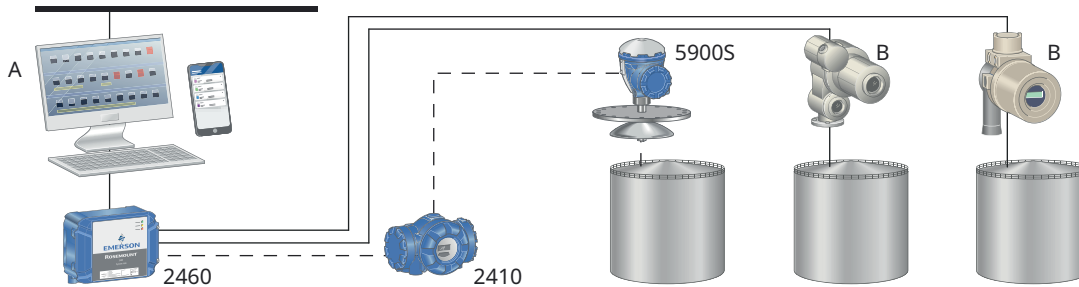
Replace your old tank management system with Rosemount TankMaster by connecting the system hub to the existing field devices, such as Enraf, Whessoe, or Varec.

Rosemount TankMaster can seamlessly replace an existing inventory management system, still being able to communicate with the field devices in use. This often enables a better update rate than before.

Emulation also enables the step-by-step modernization of a tank farm by replacing old field devices with Rosemount 5900 level gauges, temperature devices, and one or several tank hubs.

Any Modbus field device that communicates via RS485 Modbus RTU can be integrated into Rosemount 2460. Up to three device types can be defined.

**Figure 5: Replacing old Tank Monitoring software with Rosemount TankMaster**



- A. Rosemount TankMaster
- B. Float/servo gauges from other vendor in an existing system



## Rosemount 2460 System Hub



The Rosemount 2460 System Hub transfers real time tank gauging data from field devices to the Rosemount TankMaster Inventory Management Software and/or a Host/DCS system.

The system hub has eight configurable ports for host or field device communication. It supports system redundancy and emulation of other vendor devices.

[VIEW PRODUCT >](#)

### Required model components

#### Model

Code	Description
2460	System Hub

#### Capacity

Maximum number of tanks depends on selected field ports configuration. Depending on device type and application, the number of devices per tank, or number of tanks per device, may differ.

Code	Description
1	1-16 tanks
4	1-48 tanks
6	1-64 tanks

#### Firmware

Code	Description
S	Standard
1	Inventory calculation, 1-16 tanks
4	Inventory calculation, 1-48 tanks
6	Inventory calculation, 1-64 tanks

#### Redundancy/Remote access

Code	Description
0	None
R <sup>(1)</sup> (2)	Redundancy

(1) Dual Rosemount 2460 System Hub redundancy requires two system hubs with identical model codes. For redundant systems with emulation, consult factory for technical guidance.

(2) This option is required to be able to use field port redundancy and/or field device redundancy. Field port redundancy is only possible for TRL/2 and RS485 ports, where the same interface must be used on each pair. The capacity of the Rosemount 2460 is reduced when using field port redundancy.

## Modbus mapping

Code	Description
S	Standard
G <sup>(1)</sup>	User-defined Modbus mapping (Enables customized mapping for host communication.)

(1) When using Modbus TCP in combination with user-defined Modbus mapping, the same Modbus mapping will be used for all clients. In this case, TankMaster cannot be used.

## Port 1 Field communication (serial port)

See Table 1 for maximum number of devices connected to each field port.

Code	Description
R	TRL2 Modbus
E	Enraf Bi-phase Mark GPU
G	GPE (Digital Current Loop)
P	GPE (RS485)
H	Whessoe WM 550/660 (Digital Current Loop)
Y	Whessoe WM 660 (RS485)
L <sup>(1)(2)</sup>	L&J Tankway
V <sup>(1)(2)</sup>	Varec Mark/Space
U <sup>(3)</sup>	Sakura V1, MDP, BBB
T	Tokyo Keiso, TIC
4	RS485 Modbus

(1) Not supported for redundant system hubs (Redundancy option code R).

(2) External power supply is required for powering the bus.

(3) Only one protocol can be used per port.

## Port 2 Field communication (serial port)

See Table 1 for maximum number of devices connected to each field port.

Code	Description
0 <sup>(1)</sup>	None
R	TRL2 Modbus
E	Enraf Bi-phase Mark GPU
G	GPE (Digital Current Loop)
P	GPE (RS485)
H	Whessoe WM 550/660 (Digital Current Loop)
Y	Whessoe WM 660 (RS485)
L <sup>(2)(3)</sup>	L&J Tankway
V <sup>(2)(3)</sup>	Varec Mark/Space
U <sup>(4)</sup>	Sakura V1, MDP, BBB
T	Tokyo Keiso, TIC
4	RS485 Modbus

(1) Empty ports will not be enabled for use. To activate an empty port after delivery, a port upgrade must be ordered.

(2) Not supported for redundant system hubs (Redundancy option code R).

(3) External power supply is required for powering the bus.



(4) *Only one protocol can be used per port.*

### Port 3 Field communication (serial port)

See [Table 1](#) for maximum number of devices connected to each field port.

Code	Description
0 <sup>(1)</sup>	None
R	TRL2 Modbus
E	Enraf Bi-phase Mark GPU
G	GPE (Digital Current Loop)
P	GPE (RS485)
H	Whessoe WM 550/660 (Digital Current Loop)
Y	Whessoe WM 660 (RS485)
L <sup>(2)(3)</sup>	L&J Tankway
V <sup>(2)(3)</sup>	Varec Mark/Space
U <sup>(4)</sup>	Sakura V1, MDP, BBB
T	Tokyo Keiso, TIC
4	RS485 Modbus

(1) *Empty ports will not be enabled for use. To activate an empty port after delivery, a port upgrade must be ordered.*

(2) *Not supported for redundant system hubs (Redundancy option code R).*

(3) *External power supply is required for powering the bus.*

(4) *Only one protocol can be used per port.*

### Port 4 Field communication (serial port)

See [Table 1](#) for maximum number of devices connected to each field port.

Code	Description
0 <sup>(1)</sup>	None
R	TRL2 Modbus
E	Enraf Bi-phase Mark GPU
G	GPE (Digital Current Loop)
P	GPE (RS485)
H	Whessoe WM 550/660 (Digital Current Loop)
Y	Whessoe WM 660 (RS485)
L <sup>(2)(3)</sup>	L&J Tankway
V <sup>(2)(3)</sup>	Varec Mark/Space
U <sup>(4)</sup>	Sakura V1, MDP, BBB
T	Tokyo Keiso, TIC
4	RS485 Modbus

(1) *Empty ports will not be enabled for use. To activate an empty port after delivery, a port upgrade must be ordered.*

(2) *Not supported for redundant system hubs (Redundancy option code R).*

(3) *External power supply is required for powering the bus.*

(4) *Only one protocol can be used per port.*

**Port 5 Field or host communication (serial port)**

See [Table 1](#) for maximum number of devices connected to each field port.

Code	Description
00 <sup>(1)</sup>	None
FR	TRL2 Modbus, field communication
FE	Enraf Bi-phase Mark GPU, field communication
FG	GPE (Digital Current Loop), field communication
FP	GPE (RS485), field communication
FH	Whessoe WM 550/660 (Digital Current Loop), field communication
FY	Whessoe WM 660 (RS485), field communication
FL <sup>(2)(3)</sup>	L&J Tankway, field communication
FV <sup>(2) (3)</sup>	Varec Mark/Space, field communication
FU <sup>(4)</sup>	Sakura V1, MDP, BBB
FT	Tokyo Keiso, TIC
F4	RS485 Modbus (Fieldbus)
H8 <sup>(5)</sup>	Enraf CIU 858 emulation (RS485)
HR	TRL2 Modbus, host communication
H4	RS485 Modbus, host communication

(1) Empty ports will not be enabled for use. To activate an empty port after delivery, a port upgrade must be ordered.

(2) Not supported for redundant system hubs (Redundancy option code R).

(3) External power supply is required for powering the bus.

(4) Only one protocol can be used per port.

(5) Emulation of Enraf CIU 858 and configuration via Enraf FlexConn for connection to existing host system or service/configuration tool.

**Port 6 Field communication (serial port)**

See [Table 1](#) for maximum number of devices connected to each field port.

Code	Description
00 <sup>(1)</sup>	None
FR	TRL2 Modbus, field communication
FE	Enraf Bi-phase Mark GPU, field communication
FG	GPE (Digital Current Loop), field communication
FP	GPE (RS485), field communication
FH	Whessoe WM 550/660 (Digital Current Loop), field communication
FY	Whessoe WM 660 (RS485), field communication
FL <sup>(2)(3)</sup>	L&J Tankway, field communication
FV <sup>(2)(3)</sup>	Varec Mark/Space, field communication
FU <sup>(4)</sup>	Sakura V1, MDP, BBB
FT	Tokyo Keiso, TIC
F4	RS485 Modbus (Fieldbus)
H8 <sup>(5)</sup>	Enraf CIU 858 emulation (RS485)
HR	TRL2 Modbus, host communication

Code	Description
H4	RS485 Modbus, host communication

- (1) Empty ports will not be enabled for use. To activate an empty port after delivery, a port upgrade must be ordered.
- (2) Not supported for redundant system hubs (Redundancy option code R).
- (3) External power supply is required for powering the bus.
- (4) Only one protocol can be used per port.
- (5) Emulation of Enraf CIU 858 and configuration via Enraf FlexConn for connection to existing host system or service/configuration tool.

**Port 7 Host communication (serial port)**

Code	Description
00 <sup>(1)</sup>	None
TR	TRL2 Modbus communication to TankMaster
T2	RS232 Modbus communication to TankMaster
T4	RS485 Modbus communication to TankMaster
HE <sup>(2)</sup>	Enraf CIU 858 emulation (RS232)
H8 <sup>(2)</sup>	Enraf CIU 858 emulation (RS485)
HR	TRL2 Modbus communication to host/DCS
H2	RS232 Modbus communication to host/DCS
H4	RS485 Modbus communication to host/DCS

- (1) Empty ports will not be enabled for use. To activate an empty port after delivery, a port upgrade must be ordered.
- (2) Emulation of Enraf CIU 858 and configuration via Enraf FlexConn for connection to existing host system or service/configuration tool.

**Port 8 Host communication (serial port)**

Code	Description
TR	TRL2 Modbus communication to TankMaster
T2	RS232 Modbus communication to TankMaster
T4	RS485 Modbus communication to TankMaster

**OPC host communication (Ethernet)**

Code	Description
00	None

**Modbus TCP host communication**

Code	Description
00	None
MT	TankMaster TCP connection. Two TankMaster clients can connect.
MV	TankMaster TCP connection + 1 Modbus TCP client
M1 <sup>(1)(2)</sup>	1 Modbus TCP client
M5 <sup>(1)(2)</sup>	1-5 Modbus TCP clients

- (1) A redundant TankMaster system requires two clients when TankMaster is connected via Modbus TCP.
- (2) When using Modbus TCP in combination with user-defined Modbus mapping, the same Modbus mapping will be used for all clients. In this case, TankMaster cannot be used.

**Power supply**

Code	Description
P	100-250 Vac 50/60 Hz, 24-48 Vdc

**Custody transfer type approval**

Requires Rosemount 5900S Radar Level Gauge and Rosemount 2410 Tank Hub with corresponding Custody transfer type approval.

Code	Description
R	OIML R85 edition 2008
A	CMI (Czech Republic)
C	PTB Eich (Germany)
I	Ministero (Italy)
L	LNE (France)
N	NMi (The Netherlands)
O	ONML (Algeria)
T	ANM (Tunisia)
0	None

**Housing**

Code	Description
A	Aluminum (polyurethane-covered), IP 65

**Cable/conduit connections**

Code	Description
G	Metal cable glands (M20 x1.5 and M25 x1.5) <ul style="list-style-type: none"> <li>▪ 2 pcs M25 plugs</li> <li>▪ 7 pcs M20 plugs</li> <li>▪ 2 pcs M25 glands</li> <li>▪ 9 pcs M20 glands</li> </ul>
1	NPT adapters (½ -14 NPT and ¾ -14 NPT) <p>Includes:</p> <ul style="list-style-type: none"> <li>▪ 2 pcs M25 plugs</li> <li>▪ 7 pcs M20 plugs</li> <li>▪ 2 pcs ¾-14 NPT adapters</li> <li>▪ 9 pcs ½-14 NPT adapters</li> </ul>
2	Metal plugs (M20 x 1.5 and M25 x1.5) <p>Includes:</p> <ul style="list-style-type: none"> <li>▪ 2 pcs M25 plugs</li> <li>▪ 7 pcs M20 plugs</li> </ul>

**Extra**

Code	Description
0	None

## Additional options

### Floating roof monitoring

Code	Description
FR	Floating roof monitoring

### Tag plate

Code	Description
ST	Engraved SST tag plate

### Conformance certificate

Code	Description
Q1	Printed copy of certificate of conformance

### Extended warranty

Standard warranty is 18 months from delivery.

Code	Description
WR3	3-year limited warranty
WR5	5-year limited warranty

# Specifications

## Communication/configuration specifications

### Number of tanks

Each Rosemount 2460 can be configured for up to 64 tanks. The actual number of tanks depends on the electrical interface and field port configuration. For more information, see [Table 1](#).

Note that each Rosemount 5900S Radar Level Gauge with 2-in-1 functionality corresponds to two tanks.

### Number of devices per field port

[Table 1](#) lists the maximum number of devices that can be connected to each Rosemount 2460 field port. Examples of devices are Rosemount 2410, Rosemount TankRadar Pro, and legacy devices, such as Rosemount TankRadar Rex and Rosemount TankRadar TRL2.

**Table 1: Number of Devices**

Interface	Maximum number of devices connected to each field port
RS485 <sup>(1)</sup>	16
TRL2 <sup>(2)</sup>	8
Enraf BPM	10
Digital Current Loop 0-20 mA (DCL) <sup>(3)</sup>	10 <sup>(4)</sup>
L&J	10 <sup>(5)</sup>
Varec	10 <sup>(5)</sup>

- (1) Devices such as E+H NRF590 Tank Side Monitor (TSM), devices using TSM Modbus mapping, Whessoe, GPE, SI-6290/7000, Wärtsilä 1146, and user-defined Modbus devices are supported.
- (2) Devices such as Rosemount 2410 Tank Hub, Rosemount TankRadar Rex, Rosemount TankRadar Pro, TRL2 gauges, and DAU are supported.
- (3) Devices such as Whessoe and GPE are supported.
- (4) Up to 32 devices are supported when using external power.
- (5) In certain situations, more than 10 devices may work. Contact Emerson Automation Solutions/Tank Gauging Service Department for advice.

### Number of ports

**Table 2: Number of Interface Ports**

Interface	Number of ports
Modem <sup>(1)</sup>	8
Ethernet <sup>(2)</sup>	3
USB <sup>(2)</sup>	1
SD <sup>(2)</sup>	1

- (1) For more information, see [Table 4](#) and [Table 3](#).
- (2) For more information, see [Table 6](#).

Modem ports can be configured for either field or host communication according to the model code. For more information, see [Table 5](#).

### Hosts

See [Table 4](#) and [Table 5](#).

### Rosemount 2160/2165 emulation

Host protocol, supporting the Rosemount 2160/2165 Field Communication Unit input register mapping. Enables the replacement of Rosemount 2160/2165 without re-programming the host. The maximum number of tanks is reduced to 32 when using 2160 emulation.

### Digital communication protocols

**Table 3: Serial Field Communication Ports (1-6)**

Supported devices	Protocol	Electrical interface	Baud rate	Port
Rosemount 2410, TankRadar Rex gauges (with SDAU), IDAU, TankRadar Pro, and TankRadar TRL2 gauges	Modbus RTU	TRL2	4800	1-6
Rosemount 2410		RS485 (2-wire)	150-38400	
Enraf 811, 813, 854, 873, 877, 894, 970, 971, 973, and TOI-B <sup>(1)</sup>	GPU	Enraf Bi-phase Mark	1200/2400	
GPE 31422, 31423	GPE	20 mA Digital Current Loop	150-2400	
		RS485	150-38400	
Whessoe 1315, 1143	WM 550	20 mA Digital Current Loop	150-2400	
	WM 660	20 mA Digital Current Loop	150-2400	
		RS485	150-38400	
L&J 1500 XL, MCG 2000, L&J MCG 1600	L&J Tankway	L&J Tankway	300-4800	
Varec 1800, 1900	Varec Mark/Space	Varec Mark/Space	70/250	
E+H NRF590 Tank Side Monitor	Modbus	RS485	150-38400	
User-defined Modbus devices <sup>(2)</sup>				
LTD (Level, Temperature, Density) SI 6290/7000				
LTD (Level, Temperature, Density) Whessoe/Wärtsilä 1146				
Tokyo Keiso	Tokyo Keiso	Tokyo Keiso	2400	
Sakura	Sakura V1 Sakura MDP	Sakura	2400	

(1) Enraf 990 uses TOI-B for measurement data.

(2) Fully configurable up to three device types.

**Table 4: Host Communication Ports (5-8)**

Supported devices	Protocol	Electrical interface	Baud rate	Port
TankMaster	Modbus RTU	TRL2	4800	5-8
		RS485 (2-wire)	150-38400	5-8 <sup>(1)</sup>
		RS485 4-wire)		7-8 <sup>(1)</sup>
		RS232		7-8
	Modbus TCP	Ethernet	N/A	Eth1
Other hosts (DCS, SCADA etc.)	Modbus RTU	TRL2	4800	5-7
		RS485 (2-wire)	150-38400	5-7 <sup>(1)</sup>
		RS485 (4-wire)		7 <sup>(1)</sup>
		RS232		7

**Table 4: Host Communication Ports (5-8) (continued)**

Supported devices	Protocol	Electrical interface	Baud rate	Port
Enraf CIU 858 emulation <sup>(2)</sup>	GPU	RS485 (2-wire)	150-38400	5-7 <sup>(1)</sup>
		RS485 (4-wire)		7 <sup>(1)</sup>
		RS232		7

(1) Configurable termination by hardware switch.

(2) One Rosemount 2460 can replace multiple Enraf CIU 858 devices by replying to more than one separate addresses.

**Table 5: Port Configuration Options**

Ports	1	2	3	4	5	6	7	8
Alternative 6+2 (standard)	Field Port	Field Port	Field Port	Field Port	Field Port	Field Port	Host Port	Host Port
Alternative 5+3	Field Port	Field Port	Field Port	Field Port	Field Port	Host Port	Host Port	Host Port
Alternative 4+4	Field Port	Field Port	Field Port	Field Port	Host Port	Host Port	Host Port	Host Port

**Table 6: Additional Interfaces**

Electrical interface	Description
Ethernet 1 (ETH 1) <sup>(1)(2)</sup>	Modbus TCP connection to host system
Ethernet 2 (ETH 2) <sup>(2)</sup>	Connected to redundant system hub
Ethernet 3 (ETH 3) <sup>(2)</sup>	Used for accessing the web interface via a web browser for advanced configuration and service
USB 2.0 <sup>(3)</sup>	USB memory stick for logging diagnostic data
SD <sup>(3)</sup>	SD card for logging diagnostic data

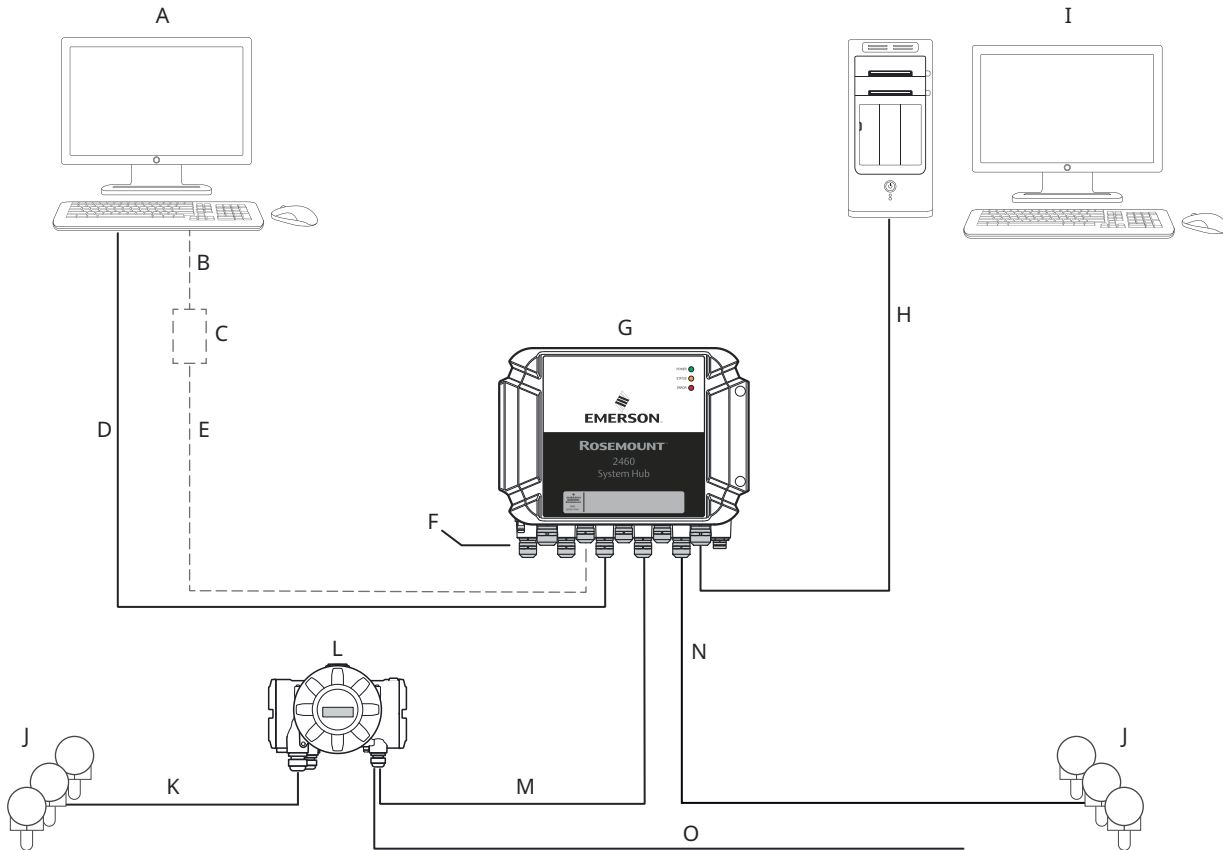
(1) When connecting the system hub to the local LAN network, make sure the connection is secure to prevent unauthorized access.

(2) CAT 5 or 6 cable is recommended.

(3) FAT32 file system.

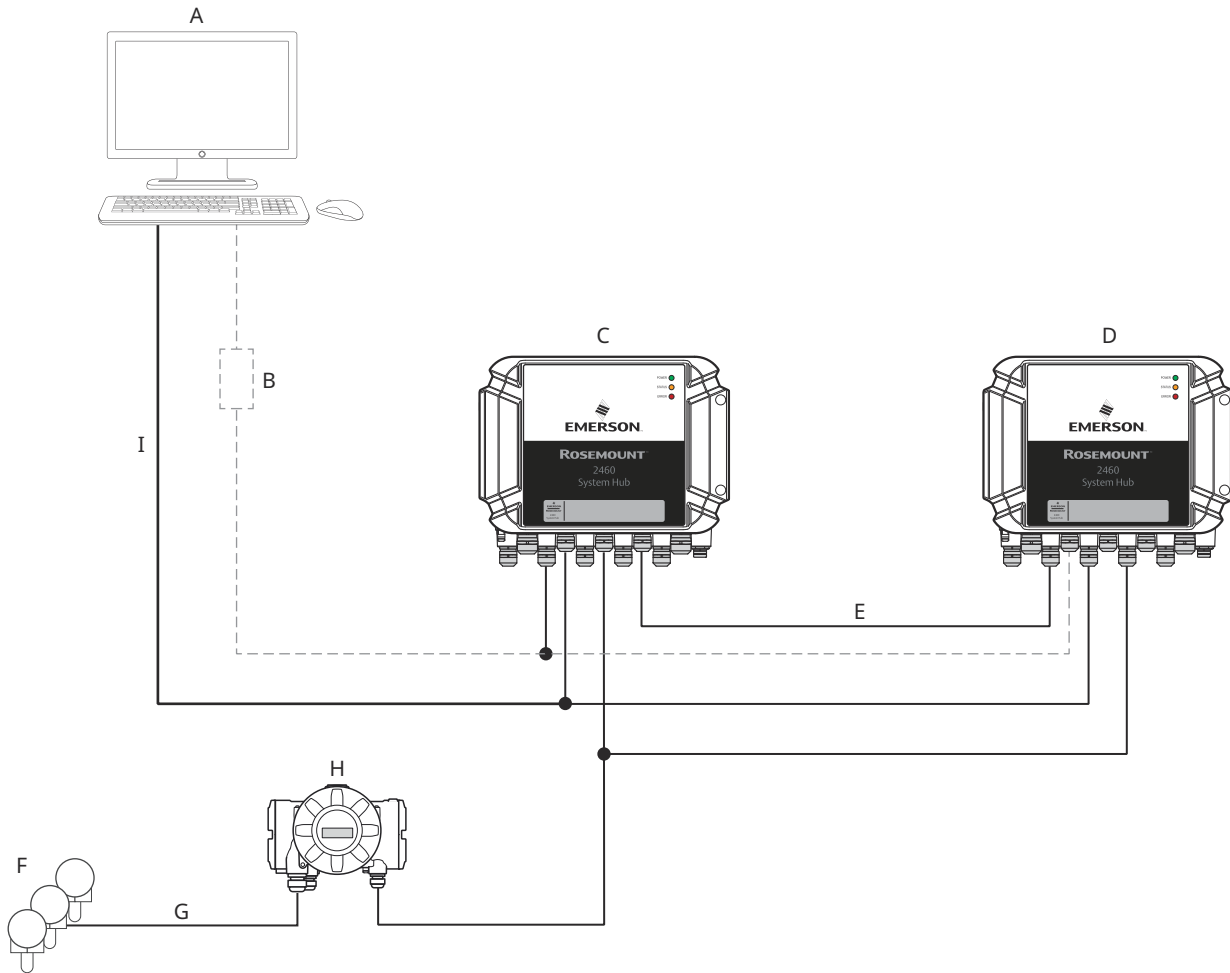


**Figure 8: Typical Configuration of a Rosemount 2460 System Hub**



- A. TankMaster™
- B. USB, RS232
- C. Modem
- D. Ethernet (Modbus® TCP), RS232, RS485
- E. TRL2, RS485
- F. Host and Field ports
- G. Rosemount 2460 System Hub
- H. Ethernet (Modbus® TCP), TRL2, RS232, RS485
- I. Other hosts
- J. Field devices
- K. Tankbus
- L. Rosemount 2410 Tank Hub
- M. Primary bus: TRL2, RS485
- N. TRL2, RS485, other vendors
- O. Secondary bus: Enraf®, Whessoe and others, HART® 4-20 mA analog output/input

Figure 9: Typical Redundant Configuration



- A. TankMaster
- B. Modem
- C. Rosemount 2460 System Hub, primary
- D. Rosemount 2460 System Hub, secondary
- E. Redundancy control signal
- F. Field devices
- G. Tankbus
- H. Rosemount 2410 Tank Hub
- I. Ethernet (Modbus TCP), RS232, RS485

## Electrical specifications

### Power supply

24-48 VDC (-15%, +10%)

100-250 VAC (-15%, +10%), 50/60 Hz ( $\pm 2\%$ )

### Power consumption

Maximum 20 W

### Cable entries

Nine M20 x 1.5 (female thread)

Two M25 x 1.5 (female thread)

### Electrical interface

See [Table 4](#), [Table 3](#) and [Table 6](#).

### Cable size

Power: 0.75 to 2.1 mm<sup>2</sup> (18-14 AWG)

Bus: 0.5 to 2.5 mm<sup>2</sup> (20-14 AWG) depending on communication interface

### Built-in mains fuses

T1.6 A

### Backup battery

3V CR 1632 lithium

## Mechanical specifications

### Housing material

Polyurethane-covered die-cast aluminum

### Installation

Wall mounted by four screws. For more information, see [Dimensional drawings](#).

### Weight

7 kg (15 lbs)

## Environmental specifications

### Temperature limits

**Ambient temperature**

-40 to 70 °C (-40 to 158 °F)

**Storage temperature**

-40 to 80 °C (-40 to 176 °F)

### Humidity limits

0-100% relative humidity

### Ingress protection

IP 65

## Additional specifications

### Metrology sealing possibility

Yes

### Write protection

Yes, via software configuration and/or hardware switch.

### Transient/built-in lightning protection

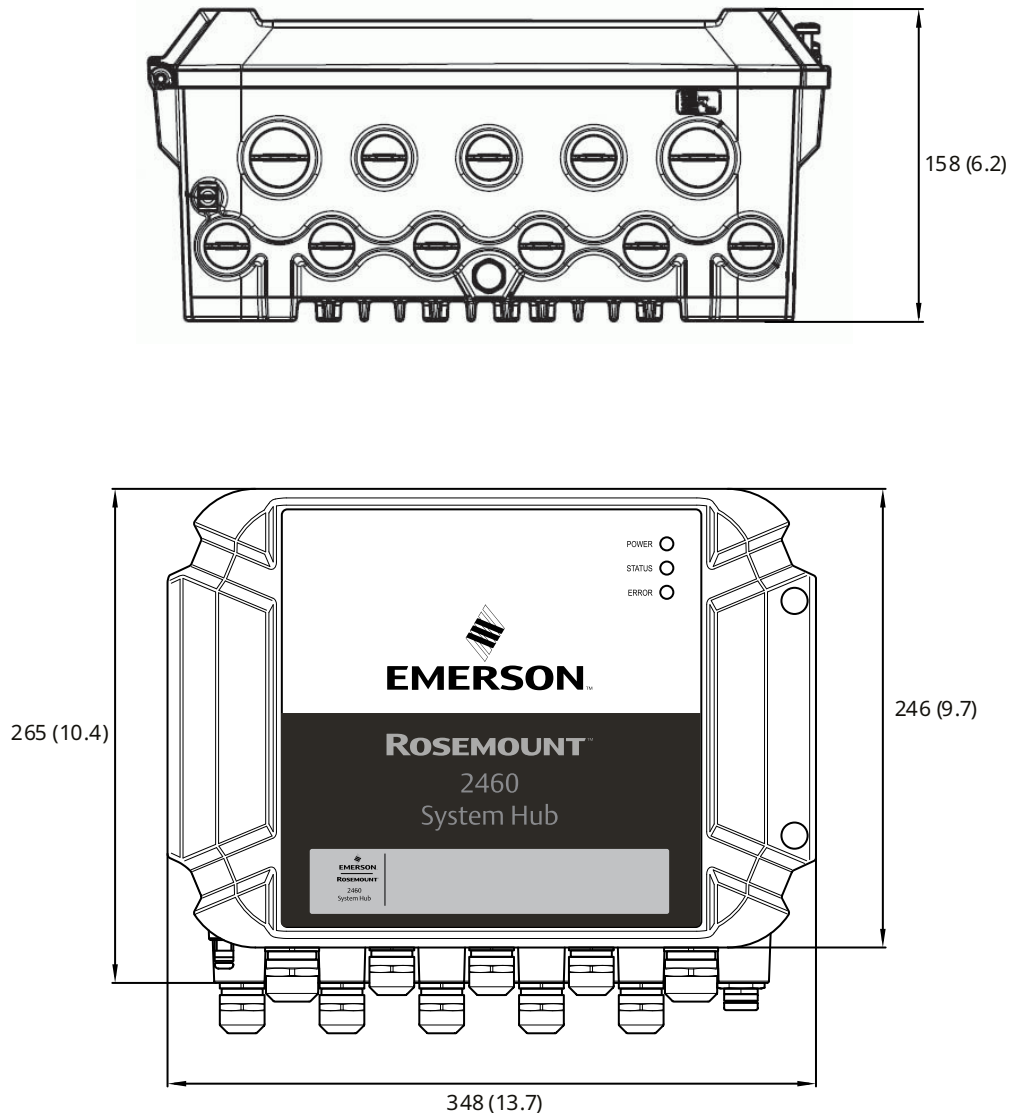
The field data ports are in accordance with IEC 61000-4-5, level 1kV line to ground.

## Product certifications

See the Rosemount 2460 [Product Certifications](#) document for detailed information on the existing approvals and certifications.

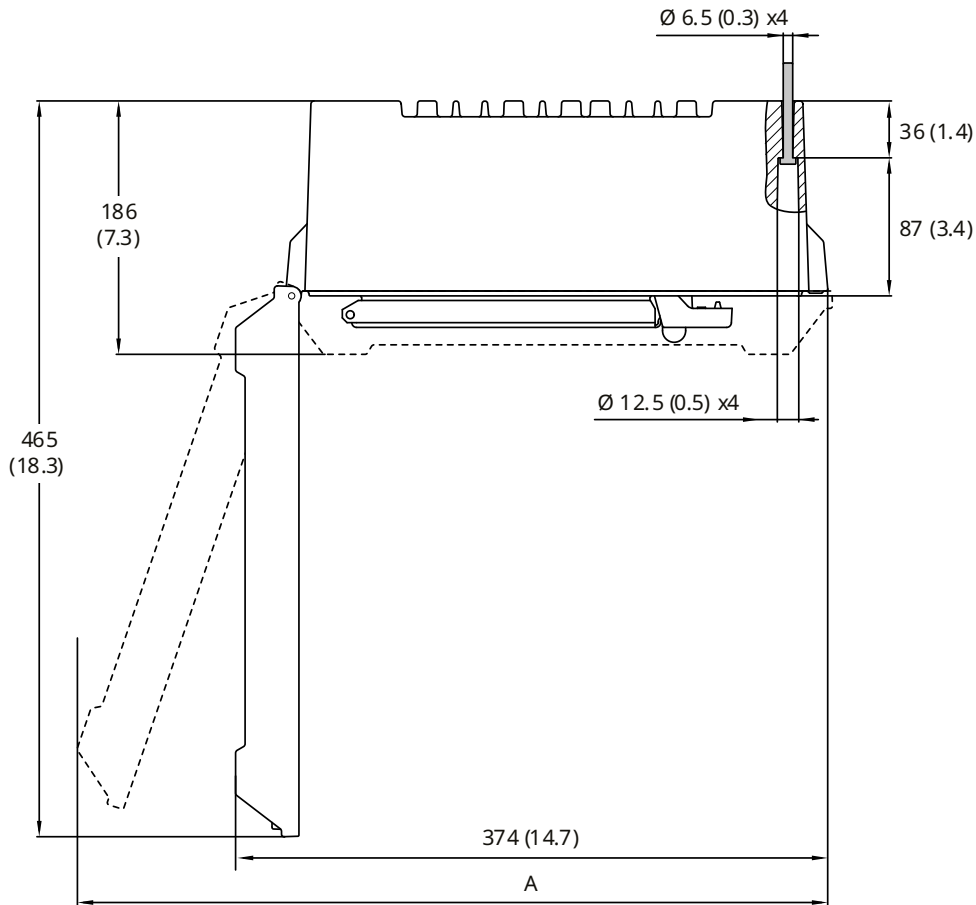
# Dimensional drawings

Figure 10: Rosemount 2460 System Hub



Dimensions are in millimeters (inches).

Figure 11: Rosemount 2460 System Hub



A. 474 (18.7) with lid maximum open

Dimensions are in millimeters (inches).



For more information: [Emerson.com/global](https://emerson.com/global)

©2024 Emerson. All rights reserved.

Emerson Terms and Conditions of Sale are available upon request. The Emerson logo is a trademark and service mark of Emerson Electric Co. Rosemount is a mark of one of the Emerson family of companies. All other marks are the property of their respective owners.

**ROSEMOUNT™**

