

Rosemount™ 2230 Graphical Field Display

for tank gauging systems



Presents real time tank gauging data, such as level, temperature, pressure, and total observed volume, available in nine languages and several view options

- Install in hazardous areas
- Initiate proof-test of a Rosemount 5900 Radar Level Gauge
- Obtain excellent readability with back-lit display
- Get legal custody transfer read-out
- Benefit from a 2-wire, low voltage Tankbus for easy and safe installation

Tank data where you need it

The Rosemount 2230 Graphical Field Display presents inventory tank gauging data such as level, temperature, and pressure. This intrinsically safe field display is designed for tough environments and can be installed in hazardous (Ex) locations. It provides all tank data directly in the field.

Rosemount 2230 displays data from devices connected to a Rosemount 2410 Tank Hub for as many as 10 tanks. Up to three field displays can be connected to a tank hub. The display is powered by the FISCO Tankbus. Wiring can be daisy-chained via the Rosemount 2230 terminals to other devices on the Tankbus. The field display has a built-in Tankbus terminator, which can be connected if required.

- The field display is approved for legal custody transfer
- Use the Rosemount 2230 to initiate a pre-configured proof test of a Rosemount 5900 gauge⁽¹⁾

Figure 1: Tank Gauging System Overview

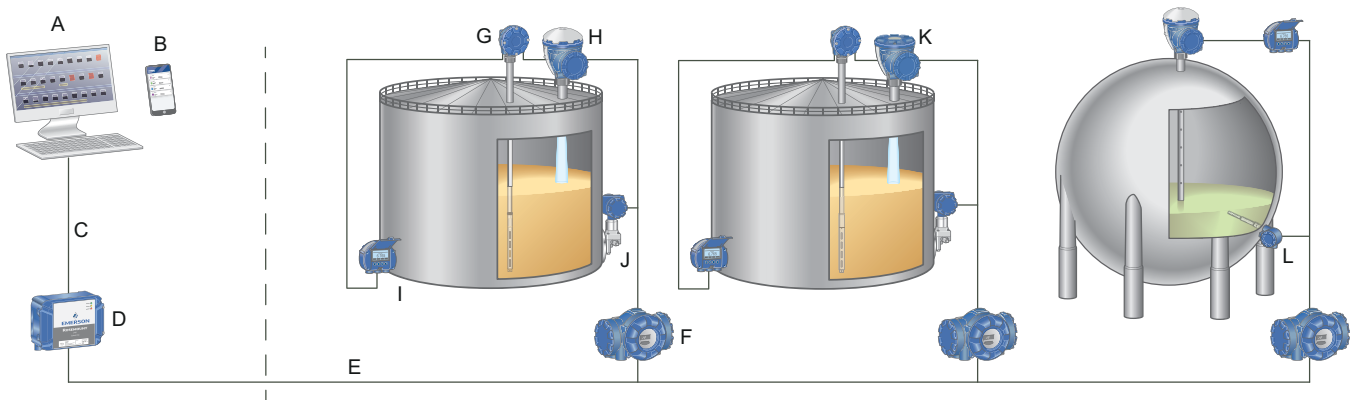

- A. Rosemount TankMaster Inventory Management
- B. Rosemount TankMaster Mobile Inventory Management
- C. Modbus® RTU/TCP
- D. Rosemount 2460 System Hub
- E. Tankbus
- F. Rosemount 2410 Tank Hub
- G. Rosemount 2240S Multi-input Temperature Transmitter with Rosemount 765 Multiple Spot Temperature and Water Level Sensor
- H. Rosemount 5900S Radar Level Gauge
- I. Rosemount 2230 Graphical Field Display
- J. Rosemount 3051S Pressure Transmitter
- K. Rosemount 5900C Radar Level Gauge
- L. Rosemount 644 Temperature Transmitter with Rosemount 65, 114C, or 214C Single Point Temperature Sensor

Contents

Tank data where you need it.....	2
Ordering information.....	4
Specifications.....	8
Product certifications.....	12
Dimensional drawings.....	13

(1) Requires that Rosemount 2230/5900 are connected to a Rosemount 2410 system.

Various installation possibilities for the easy-to-use field display

Rosemount 2230 is a back-lit user friendly display with excellent readability. The four softkeys allow you to navigate through the different menus. The field display can be installed either on the tank roof, or at the foot of the tank, for a flexible and convenient read-out of tank data.

- The field display is designed to be mounted on a wall or a pipe, using the same mounting arrangement as for other Rosemount Tank Gauging System units.
- A hinged lid protects the LCD display from sunlight exposure.

Figure 2: Rosemount 2230 Graphical Field Display

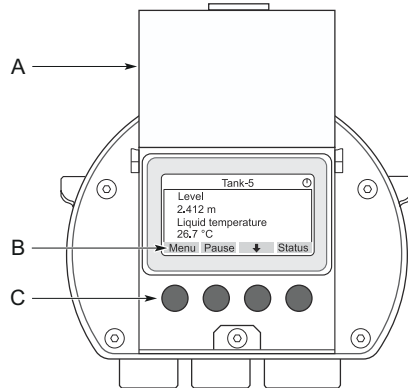

- A. *Weather protection lid*
- B. *Menu*
- C. *Softkeys*

Access information when you need it with asset tags

Newly shipped devices include a unique QR code asset tag that enables you to access serialized information directly from the device. With this capability, you can:

- Access device drawings, diagrams, technical documentation, and troubleshooting information in your MyEmerson account
- Improve mean time to repair and maintain efficiency
- Ensure confidence that you have located the correct device
- Eliminate the time-consuming process of locating and transcribing nameplates to view asset information

Ordering information

Model codes

Model codes contain the details related to each product. Exact model codes will vary; an example of a typical model code is shown in [Figure 3](#).

Figure 3: Model Code Example

<u>2230 EFS I5 RA 1 P</u>	<u>WR3 ST</u>
1	2

1. Required model components (choices available on most)
2. Additional options (variety of features and functions that may be added to products)

Rosemount 2230 Graphical Field Display



The Rosemount 2230 Graphical Field Display presents tank gauging data such as level, temperature, pressure, and total observed volume. It provides all tank data directly in the field, and offers different view options.

This back-lit user-friendly display is designed for tough environments and can be installed in hazardous (Ex) areas, on the tank roof or at the foot of the tank. It is approved for legal custody transfer.

[VIEW PRODUCT >](#)

Required model components

Model

Code	Description
2230	Graphical Field Display

Default language

Code	Description
E	English
S	Spanish
G	German
F	French
P	Portuguese
I	Italian
C	Chinese
J	Japanese
R	Russian

Tankbus: Power and communication

Code	Description
F	Bus powered 2-wire FOUNDATION™ Fieldbus (IEC 61158)

Firmware

Code	Description
S	Standard

Hazardous location certification

Code	Description
I1	ATEX Intrinsic Safety

Code	Description
I2	INMETRO Intrinsic Safety (Brazil)
I3	China Intrinsic Safety
I4	Japan Intrinsic Safety
I5	FM-US Intrinsic Safety
I6	FM-Canada Intrinsic Safety
I7	IECEx Intrinsic Safety
IM	Technical Regulations Customs Union (EAC) Intrinsic Safety
IP ⁽¹⁾	KC Intrinsic Safety (South Korea)
IW	CCOE/PESO Intrinsic Safety (India)
NA	None

(1) Requires Custody transfer type approval code R or 0.

Custody transfer type approval

Requires Rosemount 5900S Radar Level Gauge and Rosemount 2410 Tank Hub with corresponding Custody transfer type approval.

Code	Description
R	OIML R 85 edition 2008
C	PTB Eich (Germany)
K ⁽¹⁾	GOST (Kazakhstan)
L	LNE (France)
N	NMi (The Netherlands)
O	ONML (Algeria)
S ⁽¹⁾	GOST (Russia)
T	ANM (Tunisia)
0	None

(1) Requires Hazardous location certification code IM.

Housing

Code	Description
A	Standard enclosure (polyurethane-covered aluminium), IP 66/67

Cable/conduit connections

Code	Description
1	½-14 NPT, female thread (includes 1 plug)
2	M20 x 1.5 adapters, female thread (includes 2 adapters and 1 plug)
G ⁽¹⁾	Metal cable glands (½-14 NPT) (includes 2 glands and 1 plug)
E	eurofast® male connector (includes 1 connector and 1 plug)
M	minifast® male connector (includes 1 connector and 1 plug)

(1) Minimum temperature -20 °C (-4 °F). ATEX/IECEx Exe approved.

Mechanical installation

Code	Description
W	Installation kit for wall mounting
P	Installation kit for wall and pipe mounting (1-2 in. vertical and horizontal pipes)

Additional options**Tag plate**

Code	Description
ST	Engraved SST tag plate (tag shall be submitted with order)

Extended product warranty

Rosemount extended warranties have a limited warranty of three or five years from date of shipment.

Code	Description
WR3	3-year limited warranty
WR5	5-year limited warranty

Specifications

General

Material selection

Emerson provides a variety of Rosemount products with various product options and configurations, including materials of construction that can be expected to perform well in a wide range of applications. The Rosemount product information presented is intended as a guide for the purchaser to make an appropriate selection for the application. It is the purchaser's sole responsibility to make a careful analysis of all process parameters (such as all chemical components, temperature, pressure, flow rate, abrasives, contaminants, etc.), when specifying product, materials, options, and components for the particular application. Emerson is not in a position to evaluate or guarantee the compatibility of the process fluid or other process parameters with the product, options, configuration, or materials of construction selected.

Toggle time

The time each value or set of values are displayed: 2-30 s.

Language selection possibilities

English, French, German, Spanish, Italian, Chinese, Portuguese, Japanese, and Russian.

Variables to display

Level, ullage, level rate, signal strength, free water level (FWL), vapor pressure, liquid pressure, air pressure, ambient temperature, vapor average temperature, liquid average temperature, tank temperature, 1-16 spot temperature, observed density, reference density, flow rate, volume (TOV), mass, free water volume (FWV), net standard volume (NSV), middle pressure, tank height, delta level, bargraph level, and bargraph ullage.

Units to display

- Level, free water level, and ullage: meter, millimeter, feet, or imperial 1/16
- Level rate: meter/second, meter/hour, feet/second, or feet/hour
- Flow rate: meter³/hour, liter/minute, barrel/hour, UK gallon/hour, or US gallon/hour
- Total Observed Volume (TOV): meter³, liter, barrel, UK gallon, or US gallon
- Temperature: °F, °C, or °K.
- Pressure: psi, psiA, psiG, bar, barA, barG, atm, Pa, kPa, kPaA, kPaG or kg/cm²
- Density: kg/m³, kg/liter, or °API
- Signal strength: mV
- Mass: kg, tonne (metric, short, long), pound

View options

- Select View: "Single Value", "Two Values", or "Four Values". The single value view presents large 25-mm (1-in.) digits
- Options: Units, tanks (all/default/custom), variables to display, toggle time, and display language
- Service: To adjust LCD contrast, show custody transfer view, make a factory reset, or activate an LCD test feature

Electric

Power supply

Input voltage U_i for FOUNDATION™ Fieldbus:

- 9.0 to 17.5 VDC in FISCO applications
- 9.0 to 30 VDC in Entity applications

Bus current draw

30 mA

Display type

Back-lit LCD monochrome display, 128x64 pixels.

Start-up time

5 seconds

Update rate

New values to display once every two seconds

Response time

< 0.5 seconds from released button to new image

Cable entry (connection/glands)

Two ½ - 14 NPT entries for cable glands or conduits. A metal plug to seal unused port is included in the delivery.

Optional:

- M20×1.5 conduit/cable adapters
- Cable glands in metal (½ - 14 NPT)
- 4-pin male eurofast connector or A size Mini 4-pin male minifast connector

Tankbus cabling

AWG 0.5-1.5 mm² (22-16), shielded twisted pairs.

Built-in Tankbus terminator

Yes (to be connected if required)

FOUNDATION™ Fieldbus characteristics

Polarity sensitive

No

Quiescent current draw

30 mA

Lift-off minimum voltage

9.0 VDC

Device capacitance / inductanceSee [Product Certifications](#)**FOUNDATION Fieldbus class (basic or Link Master)**

Link Master (LAS)

Number of available VCRs

Maximum 38. Client and server=20, Publisher=20, Subscribers=20, Source=2, Sink=0.

Links

Maximum 32

Minimum slot time / maximum response delay / minimum intermessage delay

8/5/8

Blocks and execution time

Block	Execution time
1 Resource	N/A
3 Transducer (Main, Register, Display)	N/A
4 Multiple Analog Output (MAO)	15 ms

For more information, see the FOUNDATION™ Fieldbus Blocks [Manual](#).**Instantiation**

No

Conforming FOUNDATION™ Fieldbus

ITK 6

Field Diagnostics support (NAMUR 107)

Yes

Action support wizards

Write protect device, factory reset - device configuration, reset statistics, start/stop alerts simulation, restart communication

Advanced diagnostics

Software, memory/database, electronics, internal communication, configuration, model code, internal temperature, MAO fault state

Mechanical

Housing material

Polyurethane-coated die-cast aluminum

Dimensions (width x height x depth)

150 x 120 x 78 mm (5.9 x 4.7 x 3.1 in.)

Weight

1.3 kg (2.9 lbs)

Environment

Ambient temperature

-20 to 70 °C (-4 to 158 °F)

Storage temperature

-30 to 85 °C (-22 to 185 °F)

Humidity

0-100% relative humidity, non-condensing.

Ingress protection

IP 66 and 67 (NEMA® 4)

Metrology sealing possibility

Yes

Write protect switch

Yes

Transient / built-in lightning protection

According to IEC 61000-4-5, level 1 kV line to ground.

Complies with IEEE 587 Category B transient protection and IEEE 472 surge protection.

Installation and configuration

The Rosemount 2230 Graphical Field Display can be installed either on the tank roof or at the foot of the tank for a flexible and convenient read-out of tank data.

Cabling can be daisy-chained via the Rosemount 2230 terminals to other devices on the Tankbus. A terminator is required at each end of the Tankbus to ensure the fieldbus network will have proper signal levels. Generally, one terminator is at the fieldbus power supply and the other is in the last device in the network.

Rosemount 2230 has a built-in terminator which can be connected if required.

The Rosemount 2230 display can be installed on a wall or a 33.4-60.3 mm (1-2 in.) diameter pipe. It is important to provide space for opening the lid. The hinged lid protects the LCD display from sunlight exposure.

Configuration is done locally via the device's graphical menu and built-in buttons or remotely by using the TankMaster WinSetup software.

For more information, see the Rosemount 2230 [Reference Manual](#) or the Rosemount TankMaster [System Configuration Manual](#).

Product certifications

See the Rosemount 2230 [Product Certifications](#) document for detailed information on the existing approvals and certifications.

European Directive and UKCA Regulations Information

The most recent revision of the EU/UK Declaration of Conformity can be found at [Emerson.com/Rosemount](https://emerson.com/rosemount).

Ordinary location certification

As standard, the transmitter has been examined and tested to determine that the design meets the basic electrical, mechanical, and fire protection requirements by a nationally recognized test laboratory (NRTL) as accredited by the Federal Occupational Safety and Health Administration (OSHA).

Installing equipment in North America

The US National Electrical Code® (NEC) and the Canadian Electrical Code (CEC) permit the use of Division marked equipment in Zones and Zone marked equipment in Divisions. The markings must be suitable for the area classification, gas, and temperature class. This information is clearly defined in the respective codes.

Dimensional drawings

Figure 4: Rosemount 2230 Graphical Field Display

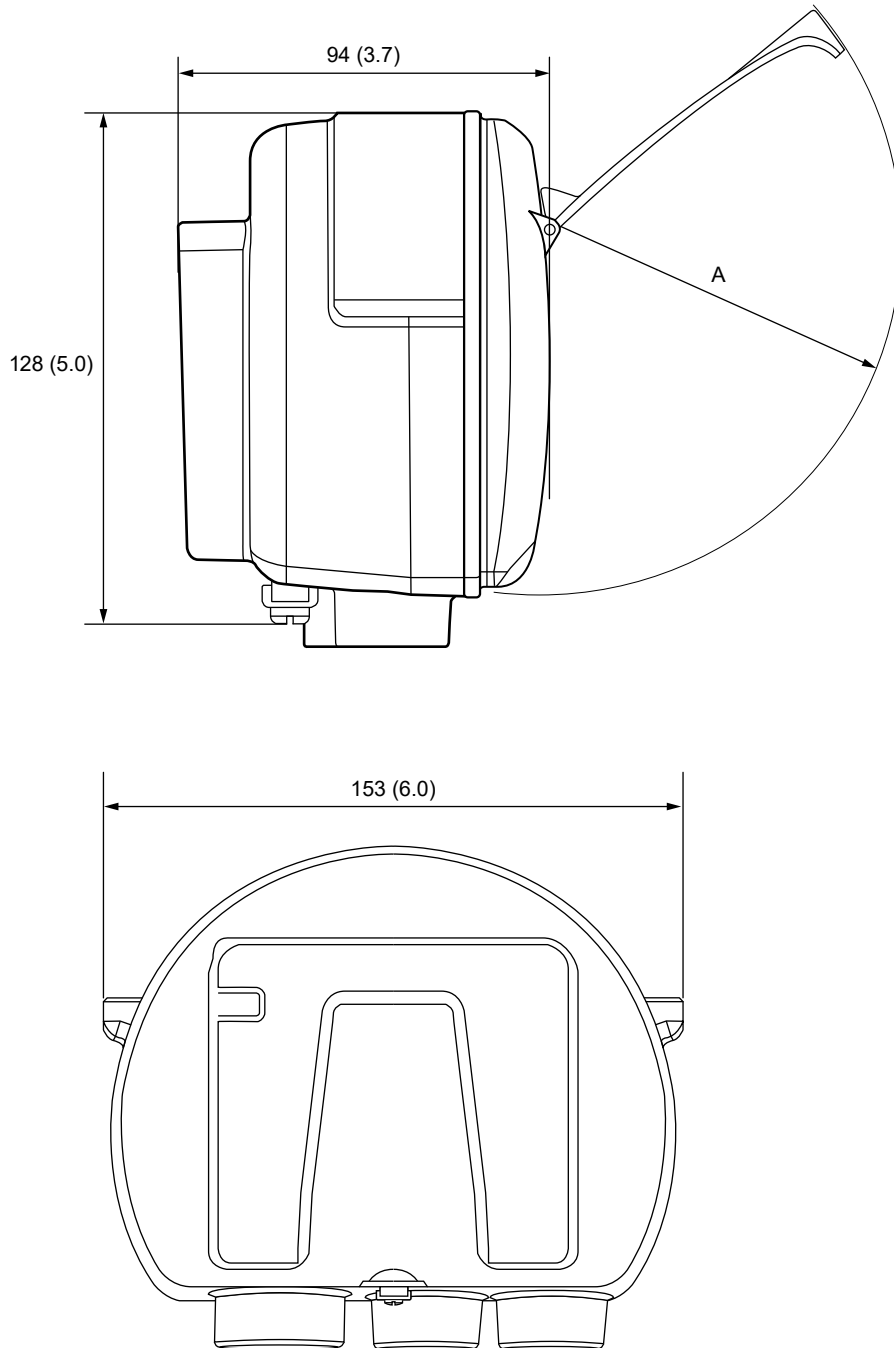

A. Radius 93 mm (3.7 in.)

Dimensions are in millimeters (inches).

©2024 Emerson. All rights reserved.

Emerson Terms and Conditions of Sale are available upon request. The Emerson logo is a trademark and service mark of Emerson Electric Co. Rosemount is a mark of one of the Emerson family of companies. All other marks are the property of their respective owners.

ROSEMOUNT™

