

DeltaV™ Electronic Marshalling

- I/O anywhere you need it
- Single channel granularity
- Reduces installed cost of system
- Fully redundant architecture
- Field-mounted capable hardware
- Plug and play I/O

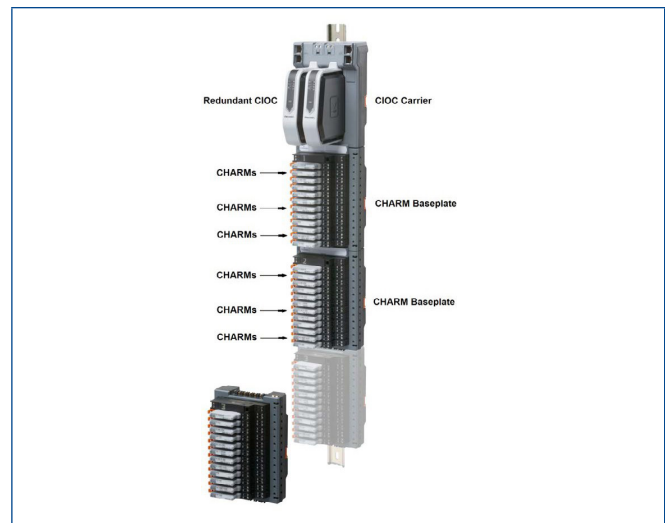

The DeltaV™ CHARM I/O Card (CIOC) with CHARMs.

Introduction

DeltaV™ Electronic Marshalling delivers a new level of control system I/O performance with unprecedented flexibility and ease of use. The CHARM I/O card (CIOC) supports up to 96 individually configurable channels and is designed specifically for multi-core home run cables in centrally located marshalling cabinets. It can also be installed in field junction boxes to further reduce system design and installation costs. All communications are completely redundant from the channel (CHARM) to the DeltaV controller.

Benefits

I/O anywhere you need it: DeltaV CIOC provides an unprecedented flexibility in control system I/O topology. Using standard Ethernet infrastructure hardware you can add I/O anywhere you need it. From a local I/O cabinet to remote enclosures miles away, simply install the hardware and connect it to the DeltaV control network. Each I/O card can serve I/O signals to any four controllers in the system with 50-ms updates for fast, reliable control.

Single channel granularity: The CHARM I/O architecture allows each individual channel to be characterized for the requirements of the field device. Any instrument signal can be wired to any terminal block. The channel is then electronically marshalled by installing the appropriate CHARM and assigning the channel to one of four controllers. Home run multi-core instrument cables can be landed in order on a series of CHARM terminal blocks without concern for signal types.

Reduces installed cost of system: DeltaV Electronic Marshalling helps reduce overall system costs by eliminating internal cabinet cross wiring, reducing overall footprint, simplifying I/O channel assignments, and reducing Factory Authorized Testing activities. Electronic Marshalling provides separation between I&E hardware installation schedules and control strategy development. Wiring can begin earlier knowing any late changes can be done without lifting a wire. Separation of the controller and I/O allows more efficient cabinet designs and accommodates late scope changes you can add I/O anywhere. Adding additional control capacity does not require re-wiring I/O. Simply assign the control modules and their I/O signals to the new controller, without lifting a wire.

Fully redundant communications: The CIOC architecture is fully redundant. It starts with the two I/O cards on a carrier. The carrier has redundant communication modules for primary and secondary network connections. There are two 24V DC input power connections. The carrier connects to the CHARMS baseplates and provides redundant power and communication buses to the CHARMS. Everything is redundant down to the individual channel.

Field-mounted capable hardware: All components of the CIOC are rated for installation in Class 1/Div 2 or Zone 2 hazardous locations. The extended operating temperature ranges and G3 environment rating allows them to be installed in field-mounted junction boxes. This further reduces the footprint required in central equipment rooms, as well as reduces the overall wiring infrastructure of traditional multi-core instrumentation cable.

Plug and Play I/O: The DeltaV CIOC has been designed for ease of use, both in physical installation and its software tools. Components snap together with secure DIN-rail latches and interlocking carrier connectors. Attach a series of 96 I/O channels to a DIN-rail in a matter of minutes. Insert the CHARMS and auto sense the node to create the I/O definition automatically in your DeltaV configuration database. CHARMS use a self keying system to automatically set a channel for a specific CHARM type. Users cannot mistakenly insert a CHARM into the wrong terminal block. Assign all, one or any number of channels to a controller with a simple click or drag and drop.



CHARM and Terminal Block.

Field power is provided through a redundant 24V DC bus to each CHARM, with up to 100 mA per CHARM. Higher current Channels can be powered through integrated power injection bus local to each CHARM Baseplate.

Product Description

Electronic Marshalling hardware includes:

- CHARM I/O Carrier (DIN rail-mounted and supports redundant pair of CHARM I/O Cards, redundant 24 V DC power connectivity, and redundant Ethernet communication modules).
- CHARM I/O Card (CIOC) provides communication between CHARMS and the Ethernet I/O network to M-series, S-series, and PK Controllers. The CIOC has Achilles Communications Certification Level 1 and the redesigned CIOC2 has more computing power and Achilles Communications Certification Level 2. The CIOC2 is a drop-in replacement for the CIOC (v13.3.1 or later is required).
- CHARM Base plate (DIN rail-mounted with interleaving power and bus connectors. Supports 12 CHARMS and their terminal blocks, as well as connection for injected field power).
- CHARM Terminal Block (removable terminal block providing terminal connections to field wiring and physical latch for CHARM).
- CHARMS (Characterization Module for each field signal. Provides basic analog to digital conversion and signal isolation to the redundant communication bus).
- Cable Extenders that provide flexibility in carrier mounting.
- I/O bus termination (provides bus terminations for redundant I/O bus).
- Labeling features for baseplate and channel identification.



CHARM I/O Card (CIOC) with CHARMs.

The CIOC carrier is mounted to the top of a vertical DIN rail and up to eight CHARM Baseplates are mounted below it, snapping easily to the DIN rail as they are connected to each other. The bus termination assembly is attached at the bottom. A standard DIN-rail lock is used to keep the entire assembly in place.

A pair of CIOCs installs on the carrier and communicates over a redundant Ethernet network with up to four controllers, allowing great flexibility and ease of system expansion. Communication modules are available for copper and fiberoptic media.

Each baseplate is ordered with 12 terminal blocks: standard terminal blocks, fused injected power terminal blocks, or relay output terminal blocks.

Electronic Marshalling eliminates the need to partition the I/O wiring to specific channels based on signal type. Simply connect field signal multi-cores in an orderly fashion as desired. Install the appropriate CHARM to complete the field circuit and the signal is ready to be used by any one of four controllers. No cross-wiring required.

Each CHARM acts as a circuit protection device and field wiring disconnect. Signals are inherently current-limited to protect against wiring faults to ground. Each CHARM provides surge protection to meet industry standards in the area of EMC. Under extreme overvoltage conditions due to incorrect field wiring, the CHARM will act as a fuse to protect adjacent channels. Signal faults are thus isolated to the single CHARM.

CHARMs can be partially ejected to a locked position that disconnects the field wiring from the system to perform field maintenance actions or to remove power to a field device. Activating the CHARM latch ejects the CHARM to the detent position. Closing the latch locks the CHARM in place and isolates the field wiring for field work.



CHARM Latch Mechanism.

Baseplate extenders and cables provide great flexibility to the CHARM installation in existing cabinets or in custom enclosures. Cables are redundant, each carrying 24V DC field power, 6.3V DC CHARM power, and one of the communication busses.

Bus termination provides added robustness for the communication bus and is installed at the end of the physical bus.

Label features are available to identify channel usage and Baseplate identification to help with maintenance.

CHARMs can be added to any existing baseplate position and autosensed online. Additional CIOCs can be added online.

CHARM Types

A variety of analog and discrete CHARMs are available to meet your specific requirements. The following CHARMs are available starting with v11.3.1:

- AI 4-20 mA HART
- RTD
- Thermocouple / mV
- AI 0-10V DC Isolated
- AO 4-20 mA HART
- DI NAMUR
- DI 24V DC low-side sense (dry contact)
- DI 24V DC Isolated
- DO 24V DC High Side
- DO 100mA Energy Limited
- DO 24V DC Isolated
- 24V DC Power
- DI 120V AC Isolated
- DI 120V AC Isolated Plus
- DI 230V AC Isolated
- DO V AC Isolated

All CHARMs have a bi-color power/integrity LED that indicates the health of the CHARM. The indications provide clear, actionable instruction to the maintenance personnel.

- Green Solid: Normal Operation
- Green Blink: Normal awaiting configuration
- Red Blink: Fault detected on wiring
- Red Solid: Internal Fault detected

Discrete CHARMs have a yellow LED to indicate the state of the field signal. (On = circuit is energized)

All CHARMs meet ISA 71.04-1985 severity level G3 (harsh) corrosion specifications.

24V DC based discrete input CHARMs support pulse counters with a maximum frequency of 10 KHz.

I/O Terminal Block Options

- There are six different I/O terminal blocks available to meet the wiring needs of field signals
- Standard Terminal Block
- Fused-Injected-Power Terminal Block
- 3-wire DI Fused Injected-Power Terminal Block
- Relay Output Terminal Block
- Thermocouple / mV Terminal Block
- 3-wire AI Fused Injected Power Terminal Block

The Standard Terminal block can be used with all CHARM types. For traditional wiring of field instrumentation, the CHARMs provide loop power through the internally distributed 24V DC field power. Refer to specific CHARM specifications for wiring information.

The Fused-Injected-Power Terminal block, the **3-wire DI Fused-Injected-Power Terminal block**, and the **3-wire AI Fused Injected Terminal block** includes a 2A field replaceable fuse. The **3-wire DI Fused-Injected-Power Terminal block** is designed to be used with all isolated discrete Input CHARM types, while the **Fused Injected Power Terminal block** is designed to work with all Isolated discrete Output CHARM types, the **3-wire AI Fused Injected Power Terminal block** is used with AI 4-20mA HART CHARM type creating a system-powered circuit that can deliver up to 1 amp (DC) to the field.

Each baseplate has a local power bus that can be connected to 24V DC or 120/230V AC through the injected power input terminals, located on the Address Plug terminal block. Both, the fused-injected power Terminal Block, the 3-wire DI fused- injected power Terminal Block, and the 3-wire AI Fused Injected Terminal block connect to this power bus to provide system power to the field circuit through the isolated CHARM. You can combine isolated and system powered circuits on the same baseplate, however, all system powered channels on a baseplate share the same power source.

The **Relay Output Terminal Block** is designed for high output current applications and requires the DO 24V DC High-side CHARM to drive the relay coil. The Relay Output Term blocks provide a normally open and normally closed contact with the following ratings:

- 28.8V DC at 5 A switching current
- 48V DC at 0.4 A switching current
- 110V DC at 0.2 A switching current
- 250V AC at 5 A switching current

The **Thermocouple / mV Terminal Block** is specially designed for the usage with the Thermocouple / mV CHARM. The Thermocouple / mV Terminal Block has fixed key positions to prevent a mismatch in the field and can only be ordered as an Assembly with the Thermocouple / mV CHARM.

The **3-wire AI Fused Injected Power Terminal Block** is designed for 3 wire analog transmitters and can be used with the AI 4-20mA HART CHARM. The field power is supplied from the injected power bus on the baseplate, but the power is not removed from the field device when the AI CHARM is removed from the baseplate. There is a Green LED on the terminal block that indicated power is supplied to the field and the 2A fuse also functions as a means to disconnect power from the field device. Although this terminal block was introduced in 2017, it is backwards compatible to any version of DeltaV with Electronic Marshalling.

Although any signal type can be installed in any location on the CHARM baseplates, it is recommended that AC voltage circuits be separated from low voltage signals to comply with safety recommendations and to mitigate induced noise in the signals. Standard Terminal blocks, Fused Injected Power terminal blocks and Relay Output Blocks can be used on the same carrier, typically, to allow the use of DO 24V DC isolated CHARMS on higher wattage and 3-wire devices alongside of standard 24V DC instrumentation signals or relay contacts.

CHARM Keying Posts

The Terminal Blocks contain keying posts that are automatically set and locked to the unique position of the installed CHARM. The keys prevent the insertion of an incorrect CHARM during maintenance activities. They are shipped in a neutral position and are set when a CHARM is inserted. If needed, the keys can be manually reset to allow a channel to be re-tasked for a different signal type.

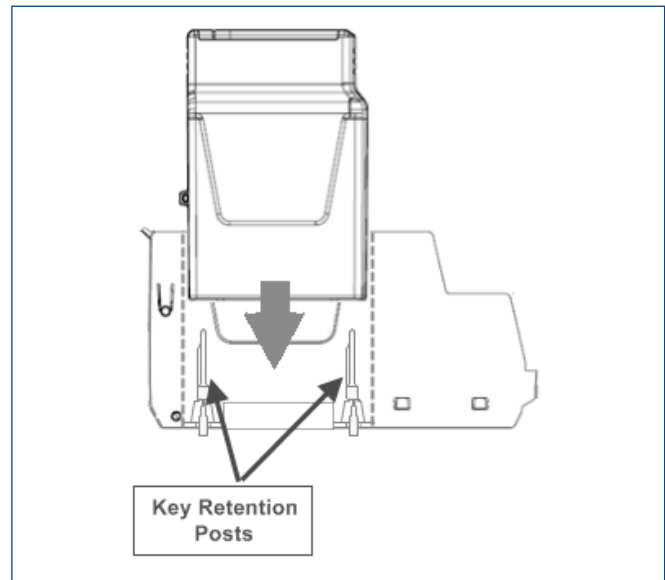

CHARM Standard Terminal block.

The keying mechanism consists of two keying posts that rotate and lock into the terminal block base. Each CHARM type is assigned a unique key setting.

ASCO Numatics 580 CHARM Node

The 580 CHARM node enables Easy solenoid valve integration into DeltaV with Electronic Marshalling. The new 580 CHARM node connects directly to the CIOC via redundant CHARM Baseplate extender cables. DeltaV can autosense the I/O as DO Solenoid Valve CHARMS the same way as any other CHARM is autosensed in DeltaV.

Benefits of the new 580 CHARM Node include:

- Redundant communications and power connections to pneumatic valve manifolds.
- Eliminates the need for additional dedicated networks like Profibus-DP and simplifies system I/O mapping.
- Expands the Electronic Marshalling I/O offering to include ASCO Numatics pilot valve manifolds, enhancing the concept of: "I/O Anywhere".
- Reduces programming and commissioning time dramatically.



ASCO Numatics 580 CHARM Node.

Hardware Specifications

Common Environmental Specifications (all components)	
Operating Temperature*	-40 to 70°C (-40 to 158°F)**
Storage Temperature	-40 to 85°C (-40 to 185°F)
Relative Humidity	5 to 95%, non-condensing
Protection Rating	IP 20
Airborne Contaminants	ISA-S71.04-1985 Airborne Contaminants Class G3 Conformal coating
Shock	10 g ½-sine wave for 11 ms
Vibration	1 mm peak-to-peak from 2 to 13.2 Hz, 0.7 g from 13.2 to 150 Hz

*Operating any electronics at the higher end of its temperature range for long periods of time will shorten its expected lifetime, see **Effects of Heat and Airflow Inside an Enclosure White Paper** for more information.

**When used with copper Ethernet I/O Ports (Copper IOP). When used with the fiberoptic I/O Ports (fiberoptic IOP), the operating temperature range is limited to -40 to 60°C (-40 to 140°F).

**When used with all CHARM Types except the DI 120 V AC Isolated Plus CHARM. When used with the DI 120 V AC Isolated Plus CHARM, the operating temperature range is limited to -40 to 60°C (-40 to 140°F).

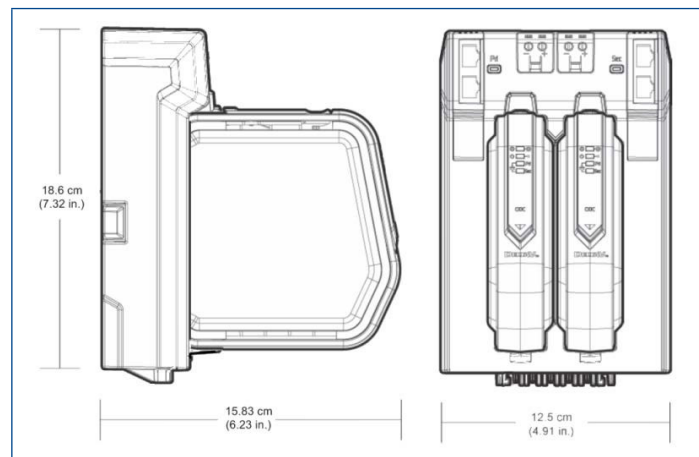

CHARM I/O Card and Carrier.

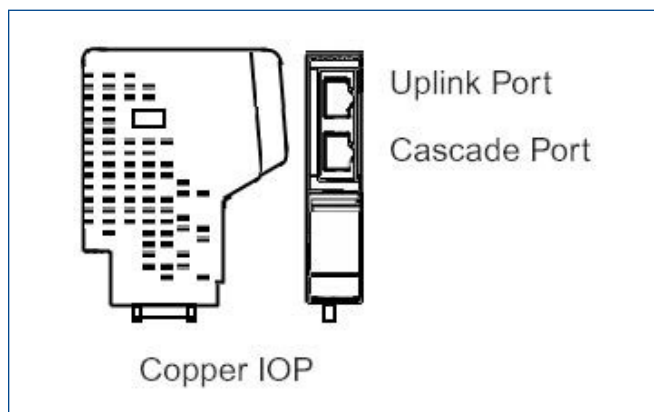

Operating Temperature -40 to 70°C (-40 to 158°F).

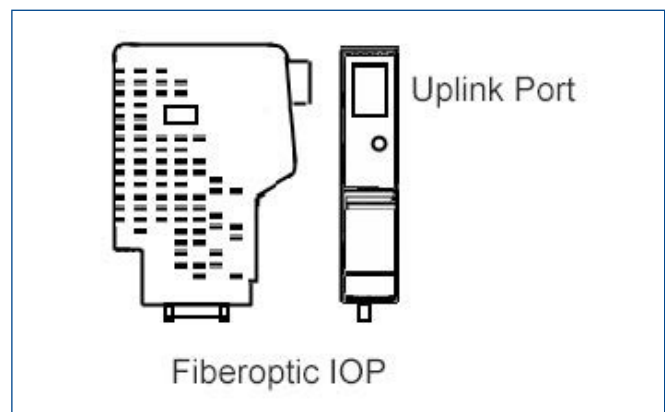

Operating Temperature -40 to 60°C (-40 to 140°F).

CIOC Carrier Ethernet Communication Modules

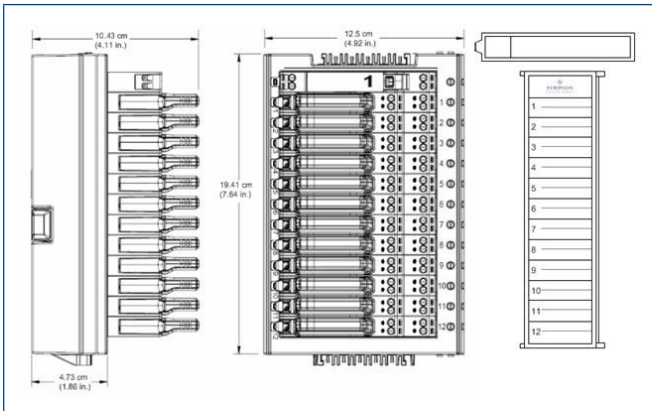

CHARM Baseplate with Identifier, CHARMs and Label Plates. Depth with DI 120V AC Isolated CHARMs will increase from 10.43 to 14.75cm.

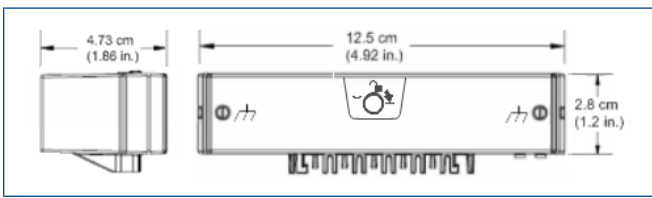

CHARM Baseplate Terminator, Top.

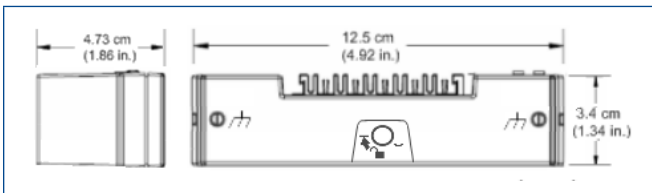

CHARM Baseplate Terminator, Bottom.

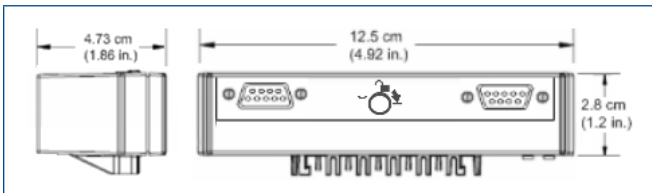

CHARM Baseplate Extender, Top.

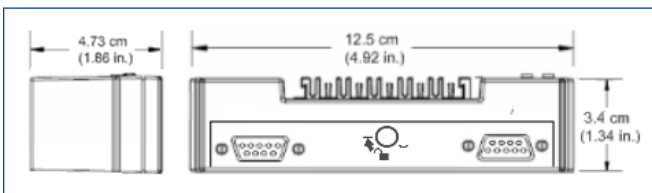

CHARM Baseplate Extender, Bottom.

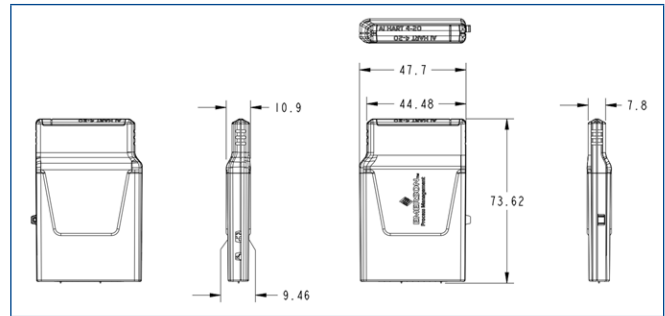

CHARMs.

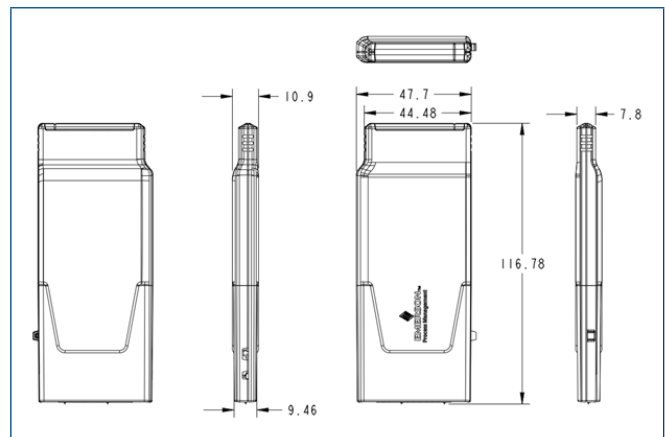

DI 120V AC Isolated Plus CHARMs.

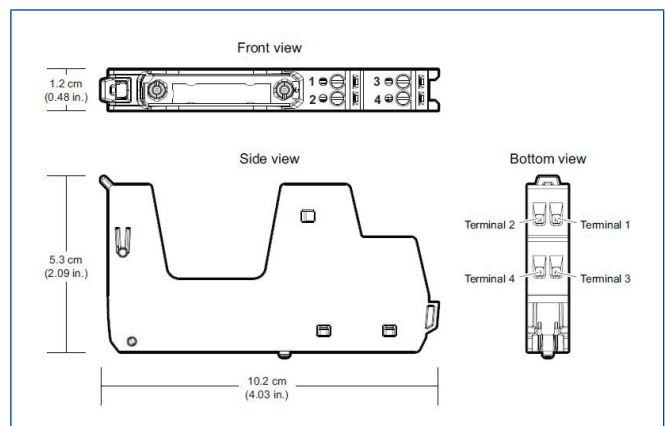

CHARM Standard Terminal Block.

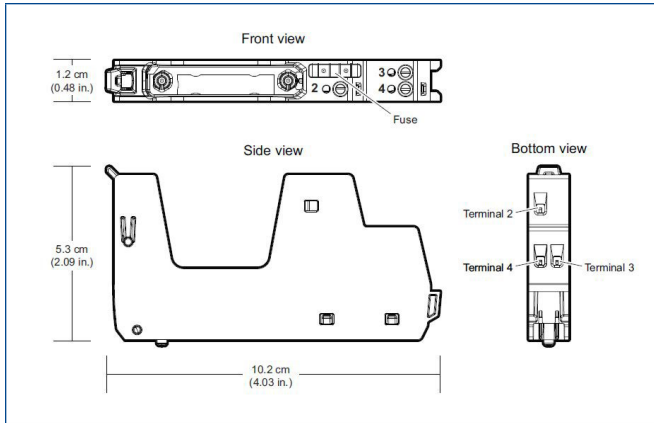

CHARM 3-wire DI Fused-Injected-Power Terminal Block.

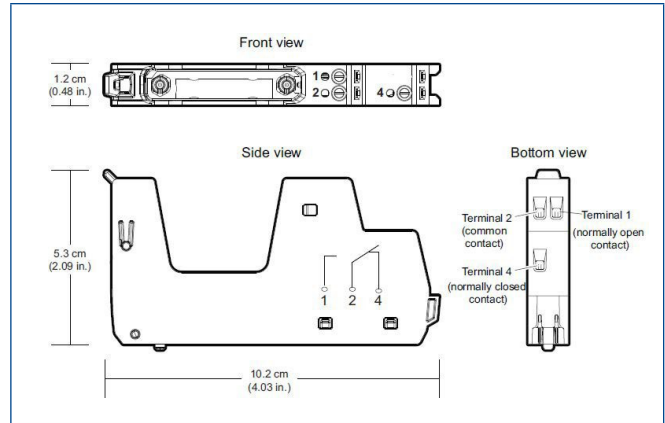

CHARM Relay Output Terminal Block.

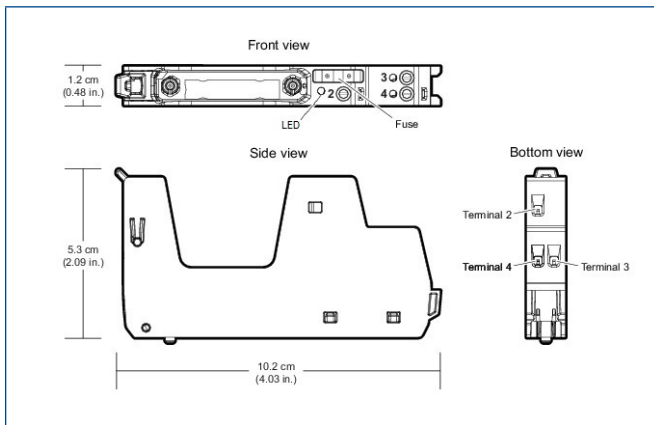

CHARM 3-wire AI Fused Injected Power Terminal Block.

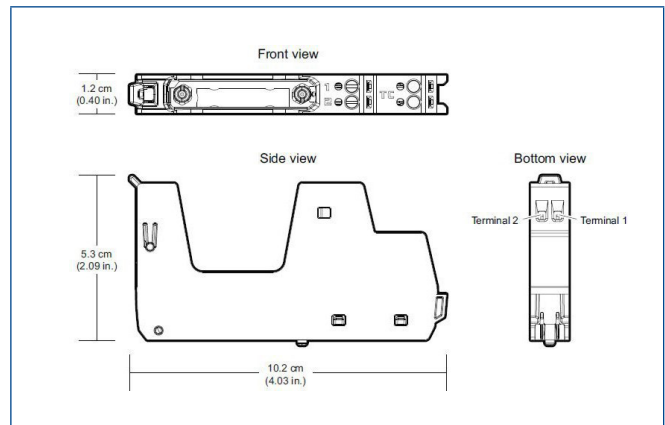

CHARM Thermocouple / mV Terminal Block.

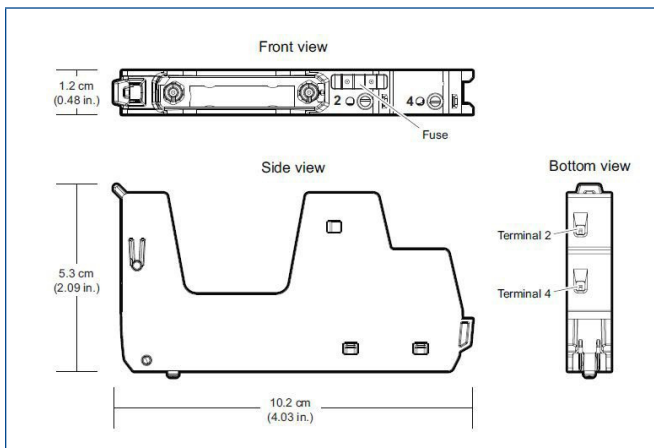

CHARM Fused Injected-Power Terminal Block.

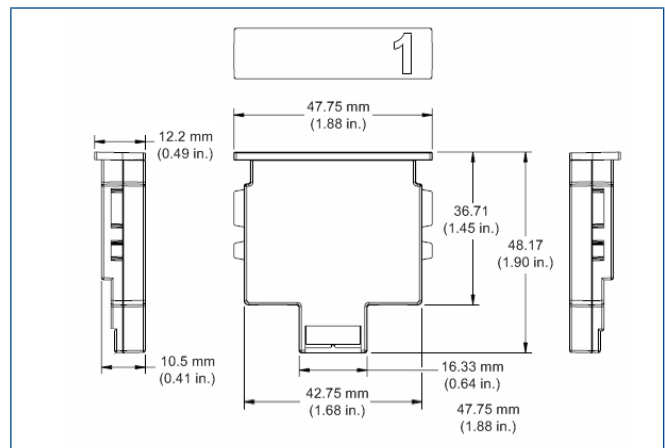

Address Plug.

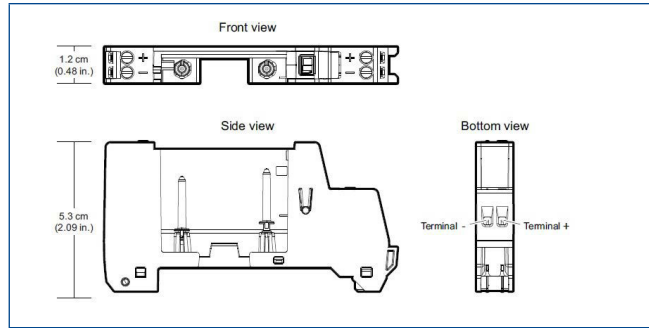

Address Plug Terminal Block.

CHARM I/O Card Hardware

Specifications for CHARM I/O Card Carrier	
Number of I/O Cards per Carrier	2 (redundant pair)
Input Power (Redundant)	+24V DC ±10% at 12 A maximum
Redundant Ethernet connections via replaceable IOPs	Fiberoptic: 100BASE-FX with MTRJ connectors; cable should have MTRJ Female connector <ul style="list-style-type: none"> ■ Full duplex operation; ■ Multimode - 2 km nominal distance. Copper twisted pair: 10/100BASE-TX with RJ45 connectors; ■ Full duplex operation ■ 100 m distance
Mounting	DIN rail Latch to vertical T-type rail
Specifications for CHARM I/O Card (CIOC) and CHARM I/O Card 2 (CIOC2)	
Number of I/O Channels	96 Channels, individually defined signal types
Number of I/O Clients	4 (Controllers)
Number of CIOCs per Controller	16
Number of CIOCs per System	300
I/O Update Rates	50ms, 100ms, 250ms, 500ms
CIOC Power (24 V DC)	0.28 A per redundant CIOC node 0.32A per redundant CIOC2 node (includes two cards and two communication modules) (individual CHARM power requirements are in addition)
CIOC Heat Dissipation	8 Watts max. per redundant CIOC node 9 Watts max. per redundant CIOC2 node <ul style="list-style-type: none"> ■ 2.0 Watts per CIOC ■ 2.5 Watts per CIOC2 ■ 1.34 Watts per Copper Ethernet I/O Communication Port ■ 2.0 Watts per Fiberoptic I/O Communication Port
CIOC output to CHARMS	6.3V DC redundant power, at 3.25 A maximum*

Fuse Protection (internal)	Internal Non-replaceable Fuse
Mounting	2-wide CHARM I/O Carrier
Communication	Redundant Ethernet connections through CHARM I/O Carrier
Network Addressing	Auto Assigned during commissioning

*Actual CIOC Output to CHARMS is dependent on number of installed CHARMS.

LED Indicators	
Green – Power	Indicates DC power is applied
Red – Error	Indicates an error condition
Green – Active/Standby	Indicates operating mode of each CIOC
Yellow Flashing – Pri./Sec. CN	Indicates valid control network communication

CHARM Baseplate	
Number of Channels per Baseplate	12
Number of Base Plates per CIOC	8
Addressing	One Address Plug (1 through 8)
Terminal Blocks	<ul style="list-style-type: none"> ■ Standard Terminal Block ■ Fused -Injected -Power Terminal Block ■ 3-wire DI Fused Injected Power Terminal Block ■ 3-wire AI Fused Injected Power Terminal Block ■ Relay Output Terminal Block ■ Thermocouple / mV Terminal Block
Shield Connections	1 Screw Cage terminal per channel, plus 1 for cable shield 0.32 – 2.5 mm ² / 22 – 14 AWG Gold plated connectors for shield continuity
Wire Strip Length	7 – 9 mm / 0.28 – 0.36 in
Mounting	DIN rail latch to T-type rail
Specifications for Baseplate Termination, Top and Bottom	
Shield Drain Wire Connections	2 Screw Cage Terminals 0.32 – 2.5 mm ² / 22 – 14 AWG
Wire Strip Length	7 – 9 mm / 0.28 – 0.36 in.

Specifications for Baseplate Extenders, Top and Bottom	
Primary Bus Connection	9-pin D-shell, Primary RS-485 communications bus Primary 24V DC field power Primary CHARM power
Secondary Bus Connection	9-pin D-shell, Secondary RS-485 communications bus Secondary 24V DC field power Secondary CHARM power
Specifications for Extender Cables	
Maximum Bus Length	A maximum of four extender pairs can be used and only one extender pair can exceed 0.5 meters (1.64 feet).
Available Cable Lengths	2 m, 1 m, 0.5 m (6.7 ft, 3.3 ft, 1.6 ft)
Specifications for Standard Terminal Block	
Number of Connections	4 Screw Cage terminals 0.32 – 2.5 mm ² / 22 – 14 AWG
Strip Length	7 – 9 mm / 0.28 – 0.36 in.
Maximum Current	2 A max. at 250V AC max.
Color	Black
Specifications for 3-wire DI Fused Injected-Power Terminal Block	
Number of Connections	3 Screw Cage terminals 0.32 – 2.5 mm ² / 22 – 14 AWG
Strip Length	7 – 9 mm / 0.28 – 0.36 in
Maximum Current	1 A max. at 250V AC max.*
Field Replaceable Fuse	2 A
Color	Black
Specifications for 3-wire AI Fused Injected Power Terminal Block	
Number of Connections	3 Screw Cage terminals 0.32 – 2.5 mm ² / 22 – 14 AWG
Strip Length	7 – 9 mm / 0.28 – 0.36 in
Maximum Current	30mA max. at 30V DC max. (screw terminal #2) 1 A max. at 30V DC max. (screw terminals #3 and #4)*
Field Replaceable Fuse	2 A
Color	Black
LED Indicator	Green – Power going to field

Specifications for Fused Injected-Power Terminal Block	
Number of Connections	2 Screw Cage terminals 0.32 – 2.5 mm ² / 22 – 14 AWG
Strip Length	7 – 9 mm / 0.28 – 0.36 in
Maximum Current	1 A max. at 250V AC max.*
Field Replaceable Fuse	2 A
Color	Black
Specifications for Relay Output Terminal Block	
Number of Connections	3 Screw Cage terminals 0.32 – 2.5 mm ² / 22 – 14 AWG
Strip Length	7 - 9 mm / 0.28 – 0.36 in.
Maximum Current	5 A at 28.8V DC / 0.4 A at 48V DC / 0.2A at 110V DC/5 A at 250V AC
Color	Black
Specifications for Thermocouple / mV Terminal Block	
Number of Connections	2 Screw Cage terminals 0.32 – 2.5 mm ² / 22 – 14 AWG
Strip Length	7 – 9 mm / 0.28 – 0.36 in
Color	Black
Specifications for Address Plug Terminal Block	
Number of Connections	2 sets of 2 connections Screw Cage terminals 0.32 – 2.5 mm ² / 22 – 14 AWG
Strip Length	7 – 9 mm / 0.28 – 0.36 in
Maximum Current	10 A max. at 250V AC max.**
Color	Black

*Actual Current draw is determined by type of CHARM and associated field devices.

**Actual Current draw through the Address Block Terminal Block is determined by the combined current draws through Injected-Power Terminal blocks on each CHARM Baseplate.

Analog Input 4-20 mA HART CHARM

Specifications for AI 4-20 mA HART CHARM	
Sensor Types	4-20 mA with or without HART 0-20 mA Supports 2-wire and 4-wire device types directly Supports 3-wire device powered through the 3-wire AI Fused Injected Power Terminal Block or the 24V DC Power CHARM
Nominal Signal Range (Span)	4-20 mA, (0-20 mA optional)
Full Signal Range	0 to 24 mA
Input Impedance	250 Ω ±1%
Field Power (2-wire)	15.0V at 20 mA @ 24V DC input
Accuracy Over Temperature Range	0.1% of span (0-60°C) 0.25% of span (over -40 -70°C)
Repeatability	0.05% of span
Resolution	16 bit A/D converter
Calibration	None required
DC/50/60 Hz Common Mode Rejection	N/A
Field Circuit Protection	<ul style="list-style-type: none"> ■ 30 mA Current Limiting circuit ■ Field wiring disconnect
CHARM Power Req.	36 mA max @ 24V DC for two wire configuration 12 mA max @ 24V DC for three and four wire configuration
CHARM Heat Dissipation	0.33 W
HART Support	HART v7 pass-through for AMS HART v7 variable and device status available to control
HART Data Update Rates	Update rates are faster than every second dependent on HART communication loading and device type

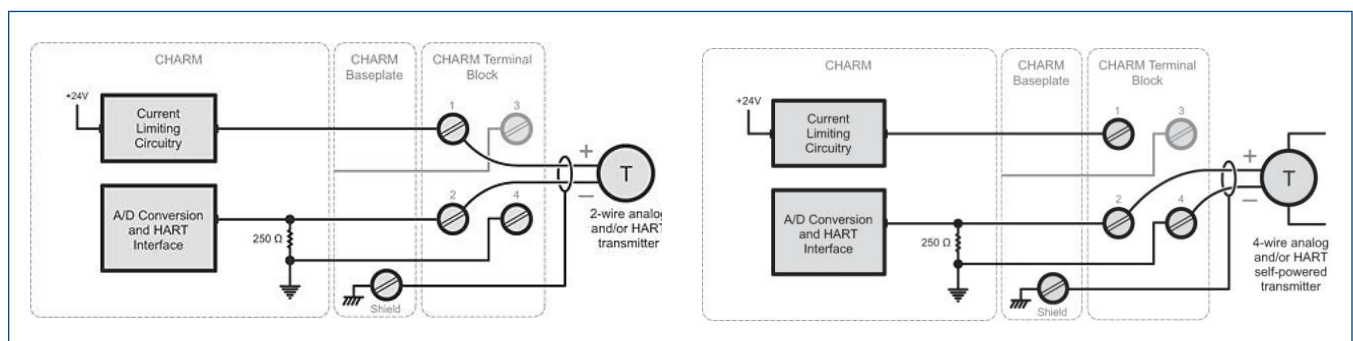

Simplified Circuit and Connection Diagrams for AI HART CHARM 0/4 to 20 mA Two-Wire and Four-Wire transmitters.

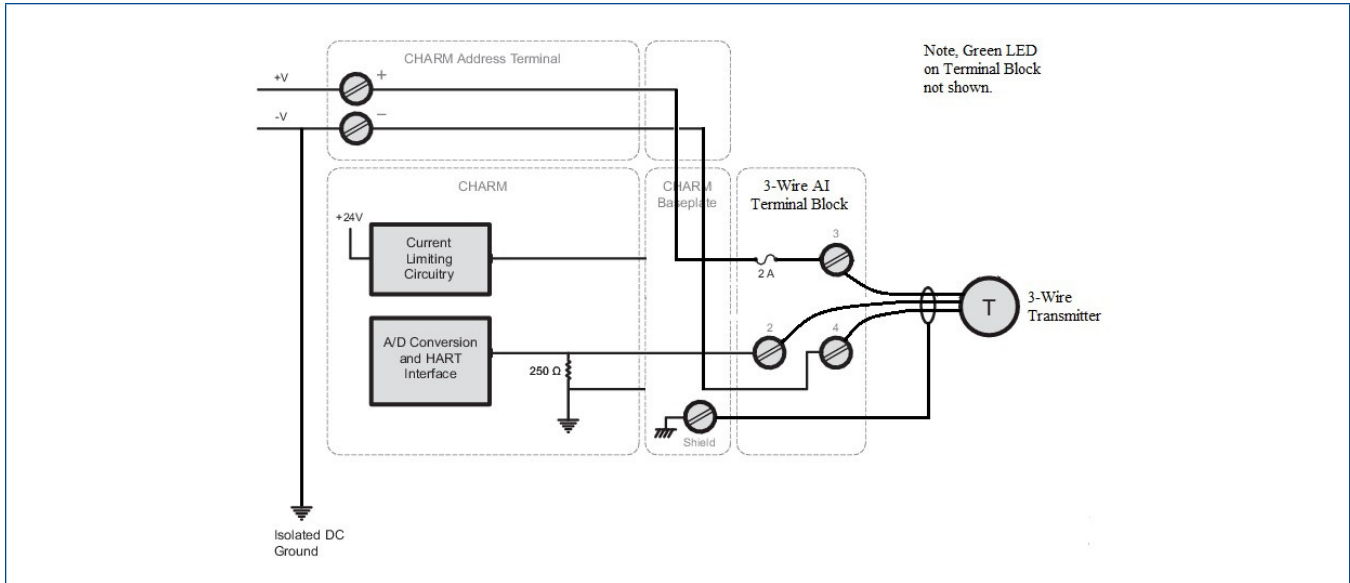

Simplified Circuit and Connection Diagrams for AI HART CHARM 0/ 4 to 20 mA with 3-wire AI Fused Injected Power Terminal Block.

RTD Input CHARM

Specifications for RTD Input CHARM	
Sensor Types	RTD input (Types listed in Table)
Sensor Configuration	2 wire, 3 wire, or 4 wire
Full Scale Signal Range	See Table next page below
Accuracy	See Table next page below
Repeatability	0.05% of span
Resolution	24 bit A/D converter / Depends upon the sensor type
Calibration	None required
Sensor Excitation Current	0.5 mA in 2-wire and 4 wire configurations 0.25 mA in 3-wire
DC/50/60 Hz Common Mode Rejection	90dB typical
Isolation	Each sensor galvanically isolated and factory tested to 1000V DC
Open Sensor Detection	Yes
CHARM Power Req.	22 mA max @ 24V DC
CHARM Heat Dissipation	0.30 W

RTD, ohms Sensor Type Specifications				
Sensor Type	Operating Range	25° Reference Accuracy	Temperature Drift	Resolution
Pt100	-200 to 850°C	± 0.25°C	± 0.02°C/°C	~0.02°C
Pt200	-200 to 850°C	± 0.25°C	± 0.02°C/°C	~0.02°C
Pt500	-200 to 850°C	± 0.25°C	± 0.02°C/°C	~0.02°C
Pt1000	-200 to 260°C	± 0.25°C	± 0.02°C/°C	~0.01°C
Ni120	-80 to 260°C	± 0.15°C	± 0.01°C/°C	~0.01°C
Ni100	-80 to 260°C	± 0.20°C	± 0.01°C/°C	~0.01°C
Ni200	-80 to 260°C	± 0.20°C	± 0.01°C/°C	~0.01°C
Ni500	-80 to 260°C	± 0.20°C	± 0.01°C/°C	~0.01°C
Ni1000	-80 to 140°C	± 0.20°C	± 0.01°C/°C	~0.01°C
Cu10	-200 to 260°C	± 0.25°C	± 0.02°C/°C	~0.01°C
Resistance/User Defined*	0 to 2,000 Ω	± 0.25 Ω	± 0.03 Ω/°C	~0.031 Ω

*The Callendar-Van Dusen linearization equation can be used with user defined Pt RTDs. Refer to Recommended I/O Practices in DeltaV Books online for usage information.

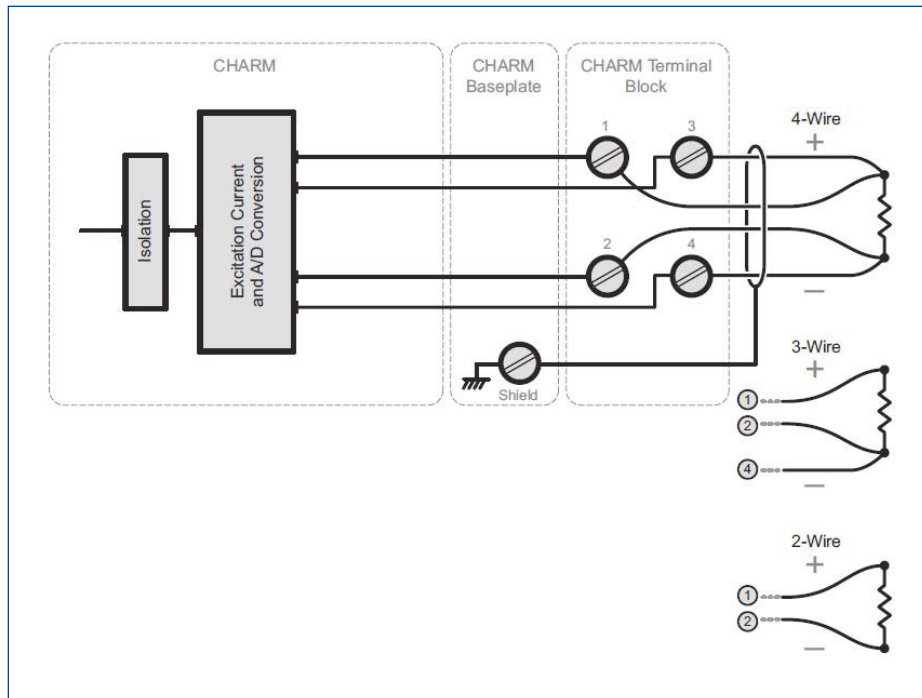

Simplified Circuit and Connection Diagrams for RTD CHARM.

Thermocouple/mV Input CHARM

Specifications for Thermocouple/mV Input CHARM	
Sensor Types	B, E, J, K, N, R, S, T, uncharacterized
<ul style="list-style-type: none"> ■ Thermocouple ■ mV 	Low level voltage source (± 20 mV, ± 50 mV, and ± 100 mV)
Full Scale Signal Range	See Table next page
Accuracy	See Table next page
Repeatability	0.05% of span
Resolution	24-bit A/D converter / Depends upon the sensor type
Calibration	None required
Cold junction Compensation (CJC)	
<ul style="list-style-type: none"> ■ Accuracy ■ Range 	$\pm 1.0^{\circ}\text{C}$ -40 to 85°C
DC/50/60 Hz Common Mode Rejection	90dB
Isolation	Each sensor galvanically isolated and factory tested to 1000V DC
Open Sensor Detection	Yes
CHARM Power Req.	22 mA max @ 24V DC
CHARM Heat Dissipation	0.30 W
Open Sensor Detection Current	45 nA

Sensor Type Specifications					
Sensor Type	25° Reference Accuracy ¹	Temperature Drift	Nominal Resolution	Full Scale	Operating Range
B	$\pm 0.8^{\circ}\text{C}$	$\pm 0.06^{\circ}\text{C}/^{\circ}\text{C}$	$\sim 0.024^{\circ}\text{C}$	0 to 1820°C	250 to 1820°C
E	$\pm 0.4^{\circ}\text{C}$	$\pm 0.03^{\circ}\text{C}/^{\circ}\text{C}$	$\sim 0.018^{\circ}\text{C}$	-270 to 1000°C	-200 to 1000°C
J	$\pm 0.6^{\circ}\text{C}$	$\pm 0.04^{\circ}\text{C}/^{\circ}\text{C}$	$\sim 0.022^{\circ}\text{C}$	-210 to 1200°C	-210 to 1200°C
K	$\pm 0.4^{\circ}\text{C}$	$\pm 0.03^{\circ}\text{C}/^{\circ}\text{C}$	$\sim 0.025^{\circ}\text{C}$	-270 to 1372°C	-200 to 1372°C
N	$\pm 0.6^{\circ}\text{C}$	$\pm 0.04^{\circ}\text{C}/^{\circ}\text{C}$	$\sim 0.024^{\circ}\text{C}$	-270 to 1300°C	-200 to 1300°C
R	$\pm 0.8^{\circ}\text{C}$	$\pm 0.05^{\circ}\text{C}/^{\circ}\text{C}$	$\sim 0.028^{\circ}\text{C}$	-50 to 1768°C	-50 to 1768°C
S	$\pm 0.8^{\circ}\text{C}$	$\pm 0.05^{\circ}\text{C}/^{\circ}\text{C}$	$\sim 0.028^{\circ}\text{C}$	-50 to 1768°C	-50 to 1768°C
T	$\pm 0.5^{\circ}\text{C}$	$\pm 0.02^{\circ}\text{C}/^{\circ}\text{C}$	$\sim 0.01^{\circ}\text{C}$	-270 to 400°C	-250 to 400°C
± 100 mV	0.025 mV	± 0.002 mV/ $^{\circ}\text{C}$	~ 0.0031 mV	-100 to 100 mV	-100 to 100 mV
± 50 mV	0.020 mV	± 0.001 mV/ $^{\circ}\text{C}$	~ 0.0015 mV	-50 to 50 mV	-50 to 50 mV
± 20 mV	0.010 mV	± 0.0005 mV/ $^{\circ}\text{C}$	~ 0.0006 mV	-20 to 20 mV	-20 to 20 mV

¹Total error is made up of the 25 C reference accuracy value, plus the CJC accuracy value, plus the (1 x R) open sensor error, plus the sensor accuracy value.

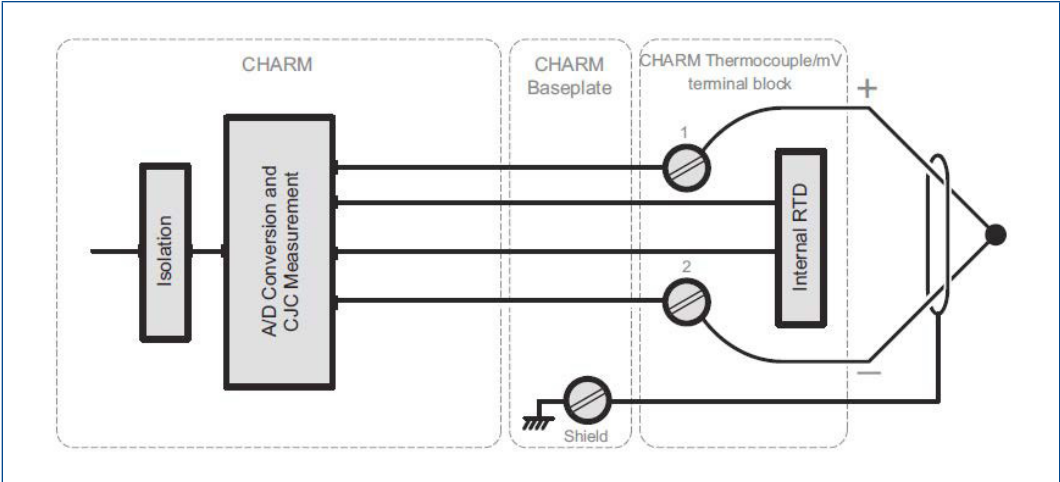

Simplified Circuit and Connection Diagram for Thermocouple/mV CHARM with Thermocouple/mV Terminal Block.

Analog Input 0-10V DC Isolated CHARM

Specifications for AI 0-10V DC Isolated CHARM	
Sensor Types	Voltage device
Full Scale Signal Range	See Table below
Accuracy	See Table below
Input Impedance	10 MΩ
Repeatability	0.05% of span
Resolution	24-bit A/D converter / Refer to the following table
Calibration	None required
Common Mode Rejection	90dB at 50/60 Hz
Isolation	Input channel galvanically isolated and factory tested to 1000V DC
CHARM Power Req.	22 mA max @ 24V DC
CHARM Heat Dissipation	0.40 W

Isolated Input Voltage Sensor Type Specifications				
Sensor Type	Sensor Range	25° Reference Accuracy	Temperature Drift	Nominal Resolution
0 to 5 V	0 to 5 V	±0.005 V	±0.0005 V/ °C	0.00008 V
0 to 10 V	0 to 10 V	±0.010 V	±0.001 V/ °C	0.00015 V
1 to 5 V	1 to 5 V	±0.005 V	±0.0005 V/ °C	0.00006 V
1 V	-1 to +1 V	±0.0025 V	±0.0002 V/ °C	0.00003 V
5 V	-5 to +5 V	±0.005 V	±0.0005 V/ °C	0.00015 V
10 V	-10 to +10 V	±0.010 V	±0.001 V/ °C	0.00030 V

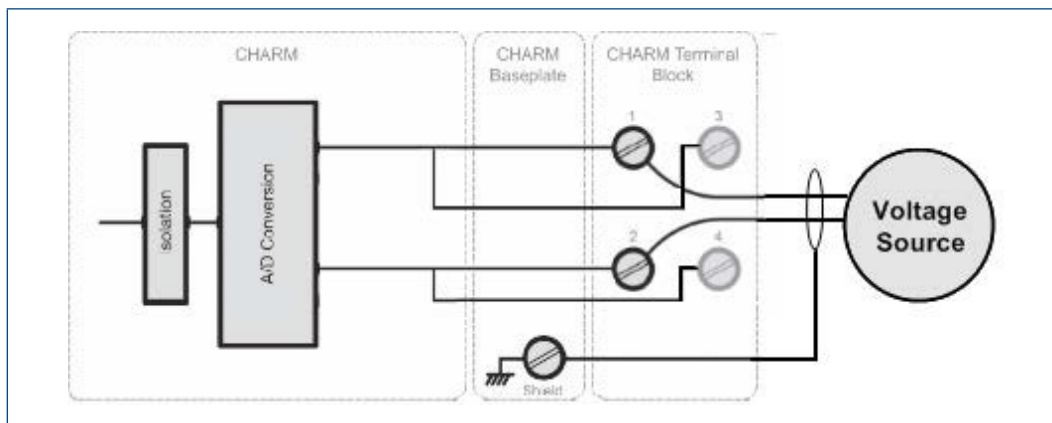

Simplified Circuit and Connection Diagram for Isolated Voltage CHARM.

Note: Installing a 250 Ω range resistor across terminals 3 and 4 converts a 4-20 mA field signal to 1-5V input signal.

Analog Output 4-20 mA HART CHARM

Specifications for AO 4-20 mA HART CHARM	
Sensor Types	4 to 20 mA with or without HART 0 to 20 mA
Nominal Signal Range (Span)	4 to 20 mA, (0 to 20 mA option)
Full Signal Range	0 to 24 mA
Accuracy Over Temperature Range	0.25% of span (0 to 60°C) 0.5% of span (-40 to 70°C)
Resolution	16-bit D/A converter
Calibration	None required
Available Field Power	20 mA at 15V DC supply into 750 Ω load
Field Circuit Protection	<ul style="list-style-type: none"> ■ 24 mA Current Limiting Circuit ■ Field wiring disconnect
CHARM Power Req.	42 mA max @ 24V DC
CHARM Heat Dissipation	0.48 W
HART Support	HART v7 pass-through for AMS HART v7 variable and device status available to control
HART Data Update Rates	Update rates are faster than every second dependent on HART communication loading and device type

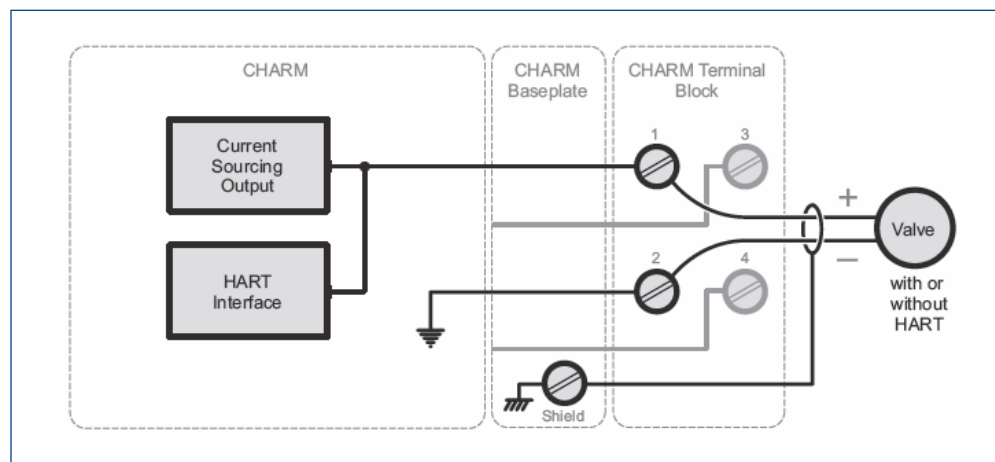

Simplified Circuit and Connection Diagram for HART AO CHARM 0/ 4 to 20 mA.

Discrete Input NAMUR CHARM

Specifications for DI NAMUR CHARM	
Sensor Types	NAMUR Sensors, Dry Contacts, Dry contact with end of line resistance
Detection Level for On	> 2.1 mA (<4 kΩ)
Detection Level for Off	< 1.2 mA (>9 kΩ)
Channel Impedance	1.5 KΩ (approximate)
Wetting Voltage*	12 Volts (± 5%)
Fault detection capable with NAMUR sensor or with an optional field resistor pack** as shown on Option 2 in diagram below (Option 1 in diagram below is not fault detection capable)	<ul style="list-style-type: none"> ■ Guaranteed short circuit: <100 Ω ■ Guaranteed good status: 400 Ω to 40 kΩ ■ Guaranteed open circuit: >75 kΩ
Configurable Channel Types: <ul style="list-style-type: none"> ■ Discrete Input ■ Pulse Count 	Dry contact or discrete state sensor changing <2 Hz Pulse train 0.1 Hz to 10 KHz, 50 μsec min pulse width
Field Circuit Protection	<ul style="list-style-type: none"> ■ 8 mA Current Limiting Circuit ■ Field Wiring Disconnect
CHARM Power Req.	28 mA max @ 24V DC
CHARM Heat Dissipation	0.51 W

*User must ensure that the instrument connected to the CHARM will operate at 12V DC. Not all NAMUR devices operate at 12V DC.

**VS6904 End of Line Resistance Module can be used for option 2, see DeltaV SIS Conditioning Components PDS for more info.

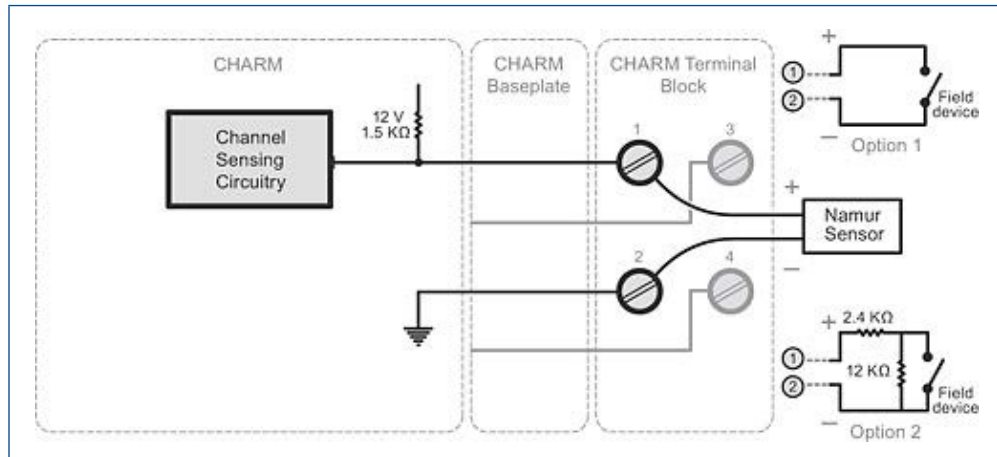

Simplified Circuit and Connection Diagram for DI NAMUR CHARM.

Discrete Input 24 V DC Low-side Sense (dry contact) CHARM

Specifications for DI 24 V DC low-side sense (dry contact) CHARM	
Sensor Types	24V DC Dry Contacts
Detection Level for On	>2.25 mA (<5.3 kΩ)
Detection Level for Off	<1.75 mA (>8.2 kΩ)
Channel Impedance	4.8 kΩ
Wetting Voltage	22.5Volts (± 5%), current limited to 12.5 mA nominal
Fault detection capable with an optional field resistor pack* as shown on Option 1 in diagram below (Without resistor pack fault detection is not possible)	<ul style="list-style-type: none"> ■ Guaranteed short circuit: <100 Ω ■ Guaranteed good status: 400 Ω to 40 kΩ ■ Guaranteed open circuit: > 75 kΩ
Configurable Channel Types: <ul style="list-style-type: none"> ■ Discrete Input ■ Pulse Count 	Dry contact or discrete state sensor changing <2 Hz Pulse train 0.1 Hz to 10 KHz, 50 μsec min pulse width
Field Circuit Protection	<ul style="list-style-type: none"> ■ 12.5 mA Current Limiting Circuit ■ Field wiring disconnect
CHARM Power Req.	22 mA max @ 24V DC
CHARM Heat Dissipation	0.33 W

*VS6904 End of Line Resistance Module can be used for option 1, see **DeltaV SIS Conditioning Components PDS** for more info.

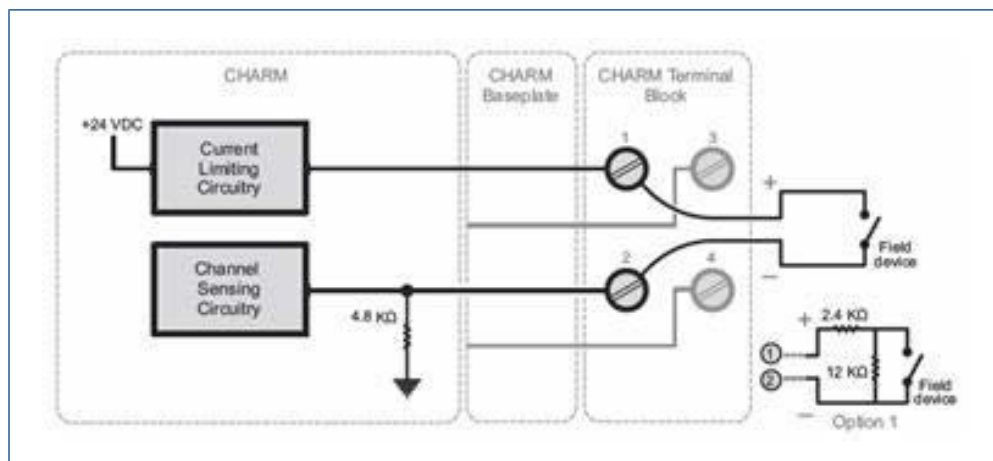

Simplified Circuit and Connection Diagram for DI 24V DC low-side sense CHARM.

Discrete Input 24V DC Isolated CHARM

Specifications for DI 24V DC Isolated CHARM	
Detection Level for On	>10V DC
Detection Level for Off	<5V DC
Wetting Current	6 mA @ 24V DC
Input Impedance	4 K Ω (approximately)
Isolation	Optically isolated and factory tested to 1000V DC
Configurable Channel Types:	
<ul style="list-style-type: none"> ■ Discrete Input ■ Pulse Count 	Dry contact or discrete state sensor changing <2 Hz Pulse train 0.1 Hz to 10 KHz, 50 μ sec min pulse width
Field Circuit Protection	<ul style="list-style-type: none"> ■ Recommend External Fuse at power source ■ Field wiring disconnect
CHARM Power Req.	12 mA max @ 24V DC
CHARM Heat Dissipation	0.32 W

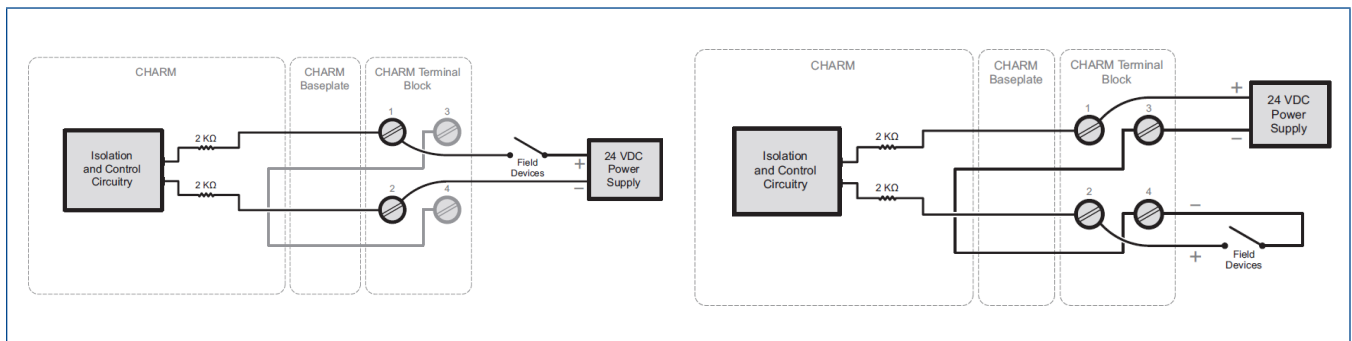

Simplified Circuit and Connection Diagrams for DI 24V DC Isolated CHARM.

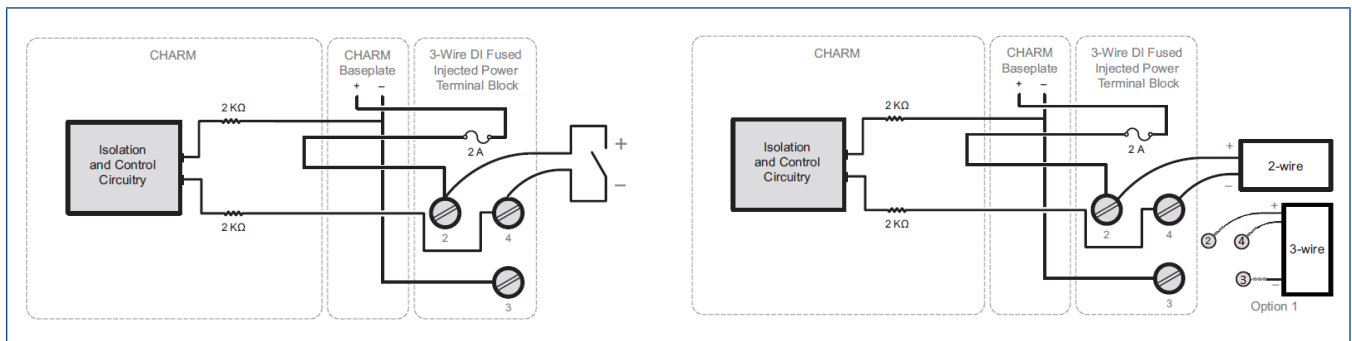

Simplified Circuit and Connection Diagrams for DI 24 V DC Isolated CHARM with 3-wire DI Fused Injected-Power Terminal Block.

Discrete Output 24V DC High-Side CHARM

Specifications for DO 24V DC High-Side CHARM	
Device Type	24V DC Solenoid coils
On State Output Rating	100 mA continuous @ 24V DC
Off State Leakage Current	1 mA maximum
Line Fault Detection	<ul style="list-style-type: none"> ■ Guaranteed short circuit: <math><50 \Omega</math> load ■ Guaranteed good status: 240 Ω to 10 kΩ load ■ Guaranteed open circuit: >20 kΩ load
Configurable Output Behavior	<ul style="list-style-type: none"> ■ Momentary Output ■ Continuous Pulse Output ■ Line fault testing
Line Fault Test Timing	200 μ sec
Field Circuit Protection	<ul style="list-style-type: none"> ■ 200 mA Current Limiting Circuit ■ Field wiring disconnect
CHARM Power Req.	116 mA max @ 24 V DC - Standard Terminal Block 24 mA max @ 24 V DC - Relay Output Terminal Block
CHARM Heat Dissipation	0.44 W - Standard Terminal Block 0.61 W - Relay Output Terminal Block

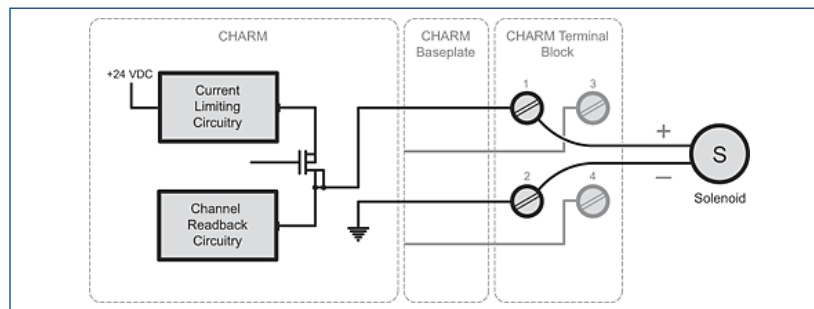

Simplified Circuit and Connection Diagram for DO 24V DC High Side CHARM.

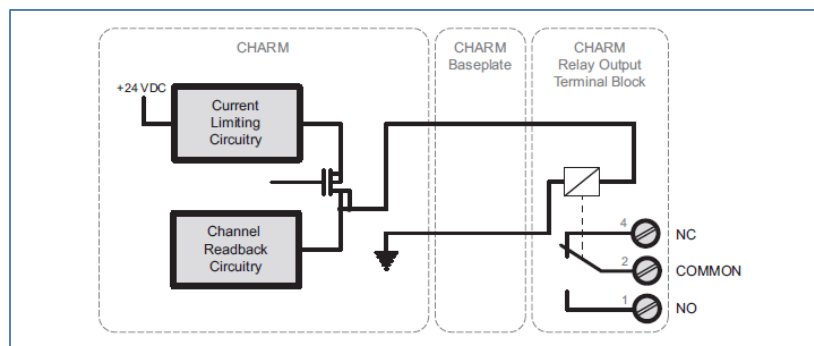

Simplified Circuit and Connection Diagram for DO 24V DC High Side CHARM with CHARM Relay Output Terminal Block.

Discrete Output 100mA Energy Limited CHARM

Specifications for DO 100 mA Energy Limited CHARM	
Device Type	24V DC Solenoid coils
On State Output Rating	100 mA continuous @ 24V DC
Off State Leakage Current	1 mA maximum
Line Fault Detection	<ul style="list-style-type: none"> ■ Guaranteed short circuit: <math><50 \Omega</math> load ■ Guaranteed good status: 240 Ω to 10 kΩ load ■ Guaranteed open circuit: >20 kΩ load
Configurable Output Behavior	<ul style="list-style-type: none"> ■ Momentary Output ■ Continuous Pulse Output ■ Line fault testing
Line Fault Test Timing	200 μ sec
Field Circuit Protection	<ul style="list-style-type: none"> ■ 107 mA Current Limiting Circuit ■ Field wiring disconnect
CHARM Power Req.	116 mA max @ 24V DC
CHARM Heat Dissipation	0.56 W

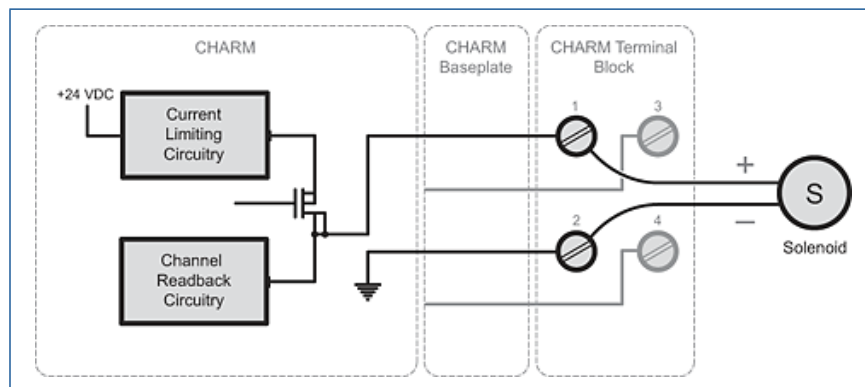

Simplified Circuit and Connection Diagram for DO 100 mA Energy limited CHARM.

Discrete Output 24V DC Isolated CHARM

Specifications for DO 24V DC Isolated CHARM	
Device Type	24V DC Inductive Load
Output Range	4V DC to 32V DC
Output Rating	1.0 A continuous (2 A inrush for <100 ms)
Off State Leakage Current	1 mA maximum
Configurable Output Behavior	<ul style="list-style-type: none"> ■ Momentary Output ■ Continuous Pulse Output
Isolation	The output channel is galvanically isolated and factory tested to 1000V DC
Field Circuit Protection	<ul style="list-style-type: none"> ■ 4 A Current Limiting Circuit (Short Circuit) with thermal shutoff, automatic reset ■ Field wiring disconnect ■ Recommend external fuse at power source
CHARM Power Req.	22 mA max @ 24V DC
CHARM Heat Dissipation	0.46 W

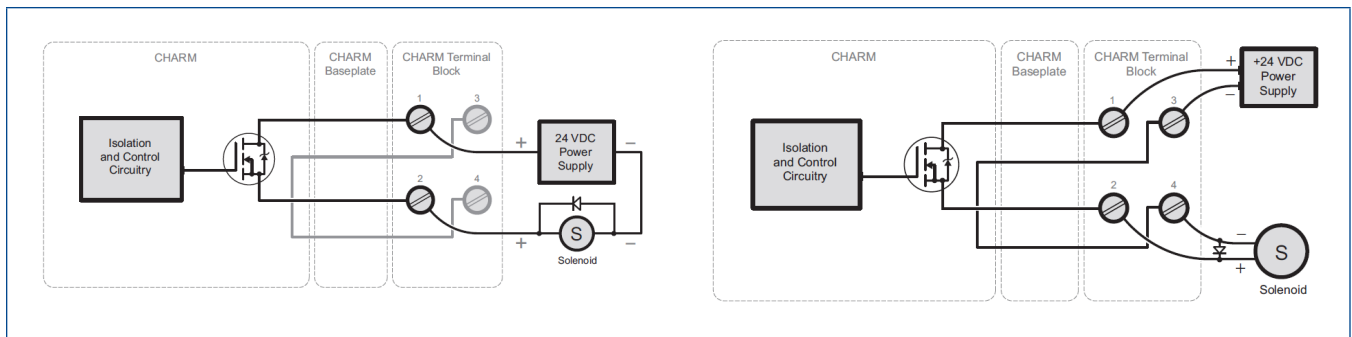

Simplified Circuit and Connection Diagrams for DO 24V DC Isolated CHARM.

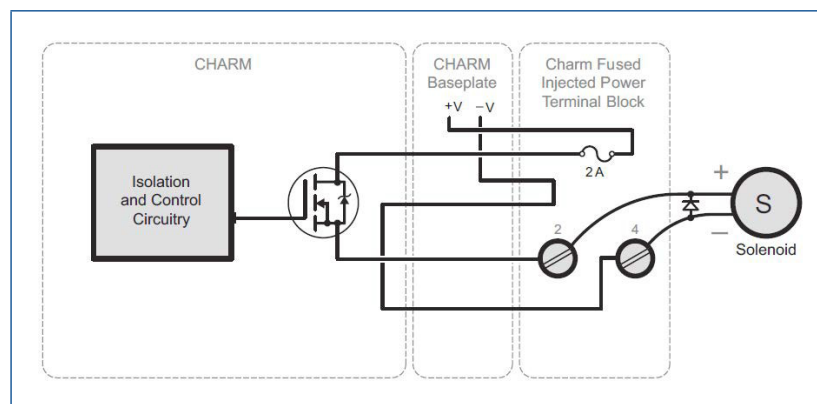

Simplified Circuit and Connection Diagrams for DO 24V DC Isolated CHARM with Fused Injected-Power Terminal Block.

24V DC Power CHARM

Specifications for 24V DC Power CHARM	
Device Type	24V DC Power output
Status Read Back Level for Power Good	>10V DC
Status Read Back Level for Power Bad	<5V DC
Isolation	Status read back circuitry is optically isolated and factory tested to 1000V DC. Output power has no isolation from the injection point.
Field Circuit Protection	<ul style="list-style-type: none"> 2 Amp fuse located in Fused-Injected-Power Terminal Block Field wiring disconnect
CHARM Power Req.	12 mA max @ 24V DC
Injected Power Req.	1.01 Amps max @ 24V DC
CHARM Heat Dissipation	0.32 W

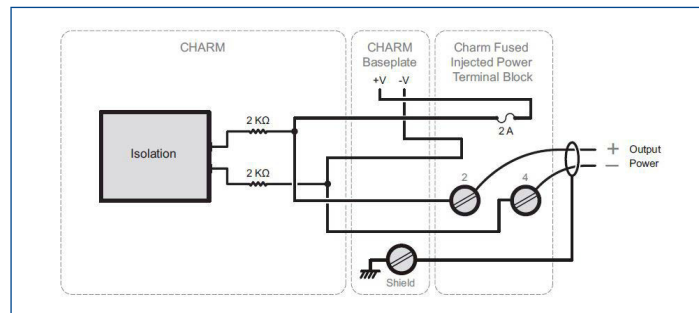

Simplified Circuit and Connection Diagrams for 24V DC Power CHARM with Fused Injected-Power Terminal Block.

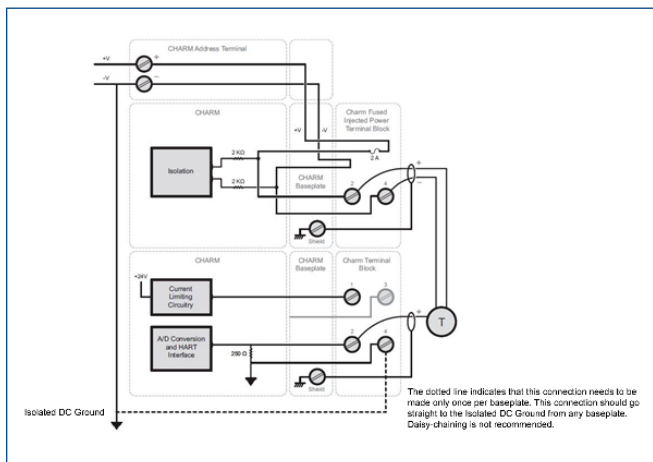

Simplified Circuit and Connection Diagrams for 24V DC Power CHARM with Fused Injected-Power Terminal Block – powering 3-wire HART Transmitter connected to AI HART CHARM 0/ 4 to 20 mA.

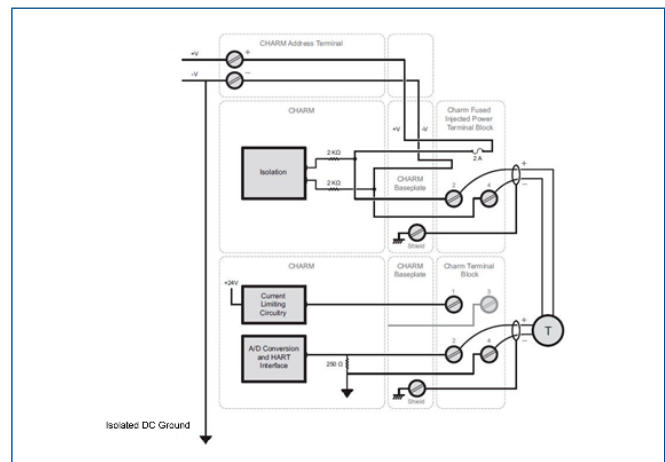

Simplified Circuit and Connection Diagrams for 24V DC Power CHARM with Fused Injected-Power Terminal Block – powering 4-wire HART Transmitter connected to AI HART CHARM 0/ 4 to 20 mA.

Discrete Input 120V AC Isolated CHARM

Specifications for DI 120V AC Isolated CHARM	
Detection Level for On	>84V AC
Detection Level for Off	<34V AC
Wetting Current	2 mA at 120V AC
Input Impedance	60 KΩ (approximately)
Maximum Input Voltage	130V AC
Frequency	50/60 Hz
Isolation	Each channel is optically isolated from the system at 250V AC
Configurable Channel Types:	
<ul style="list-style-type: none"> ■ Discrete Input ■ Pulse Count 	Dry contact or discrete state sensor changing <2 Hz Pulse train 0.1 Hz to 10 Hz
Field Circuit Protection	<ul style="list-style-type: none"> ■ Recommend External Fuse at power source ■ Field wiring disconnect
CHARM Power Req.	12 mA max @ 24V DC
CHARM Heat Dissipation	0.41 W

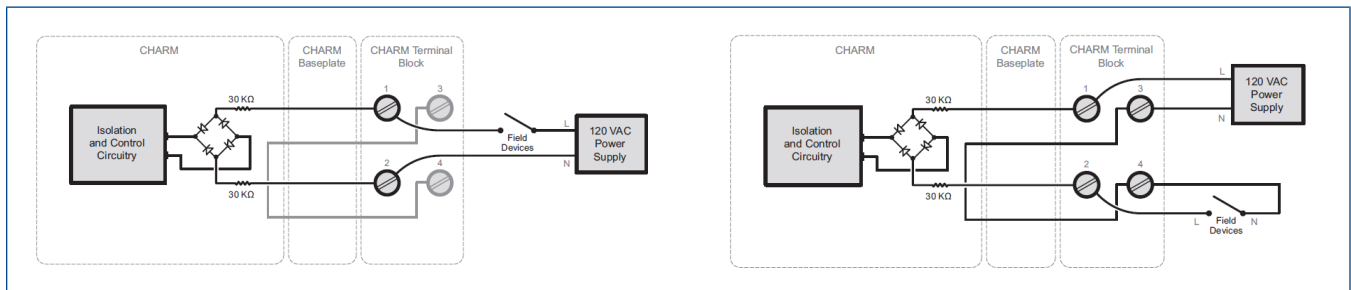

Simplified Circuit and Connection Diagrams for DI 120V AC Isolated CHARM.

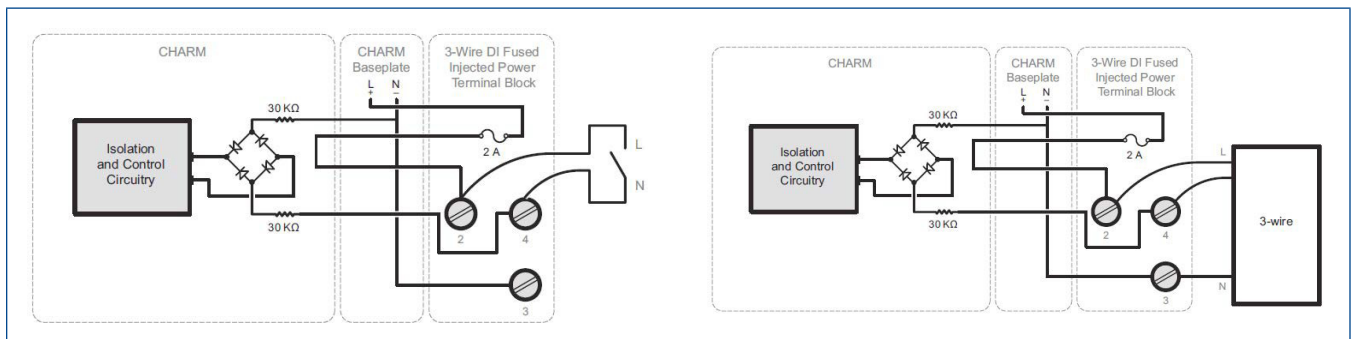

Simplified Circuit and Connection Diagrams for DI 120V AC Isolated CHARM with 3-wire DI Fused-Injected-Power Terminal Block.

Discrete Input 120V AC Isolated Plus CHARM

Specifications for DI 120V AC Isolated Plus CHARM	
Detection Level for On	>84V AC
Detection Level for Off	<34V AC
Wetting Current	10 mA at 120V AC
Input Impedance	12 K Ω (approximately)
Maximum Input Voltage	130V AC
Frequency	50/60 Hz
Isolation	Each channel is optically isolated from the system at 250V AC
Configurable Channel Types:	
<ul style="list-style-type: none"> ■ Discrete Input ■ Pulse Count 	Dry contact or discrete state sensor changing <2 Hz Pulse train 0.1 Hz to 10 Hz
Field Circuit Protection	<ul style="list-style-type: none"> ■ Recommend External Fuse at power source ■ Field wiring disconnect
CHARM Power Req.	12 mA max @ 24V DC
CHARM Heat Dissipation	1.3 W

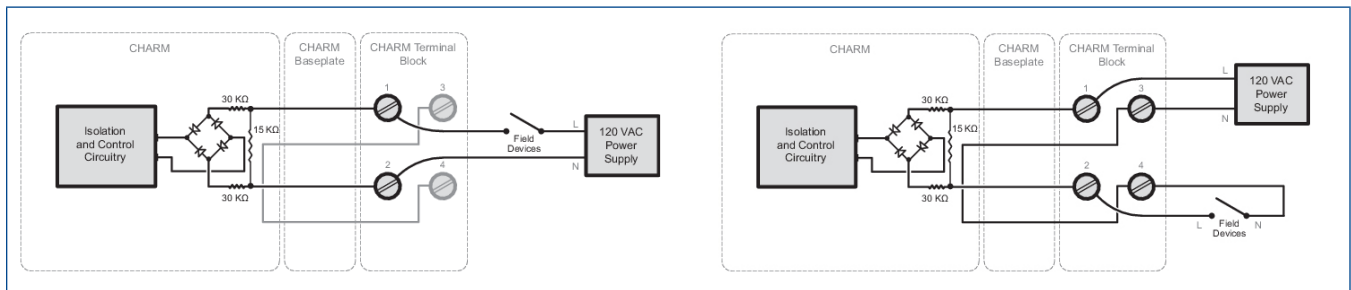

Simplified Circuit and Connection Diagrams for DI 120V AC Isolated Plus CHARM.

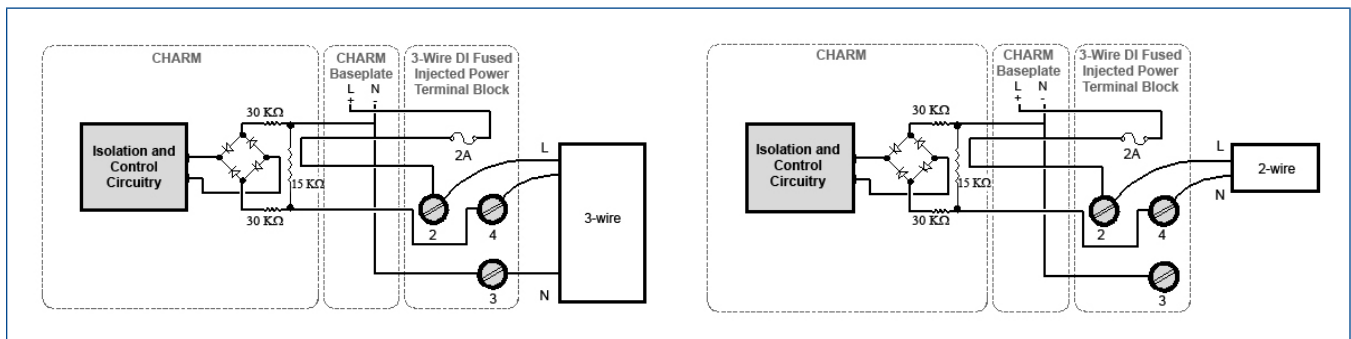

Simplified Circuit and Connection Diagrams for DI 120V AC Isolated Plus CHARM with 3-wire DI Fused-Injected-Power Terminal Block.

Discrete Input 230V AC Isolated CHARM

Specifications for DI 230V AC Isolated CHARM	
Detection Level for On	>168V AC
Detection Level for Off	<68V AC
Wetting Current	1 mA at 230V AC
Input Impedance	240 KΩ (approximately)
Maximum Input Voltage	250V AC
Frequency	50/60 Hz
Isolation	Each channel is optically isolated from the system at 250V AC
Configurable Channel Types: <ul style="list-style-type: none"> ■ Discrete Input ■ Pulse Count 	Dry contact or discrete state sensor changing <2 Hz Pulse train 0.1 Hz to 10 Hz
Field Circuit Protection	<ul style="list-style-type: none"> ■ Recommend External Fuse at power source ■ Field wiring disconnect
CHARM Power Req.	12 mA max @ 24V DC
CHARM Heat Dissipation	0.40 W

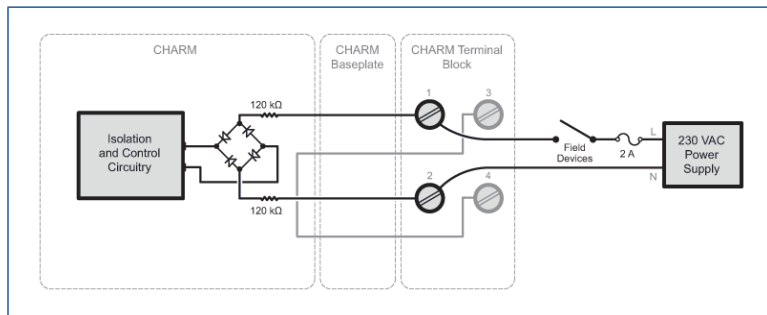

Simplified Circuit and Connection Diagrams for DI 230V AC Isolated CHARM.

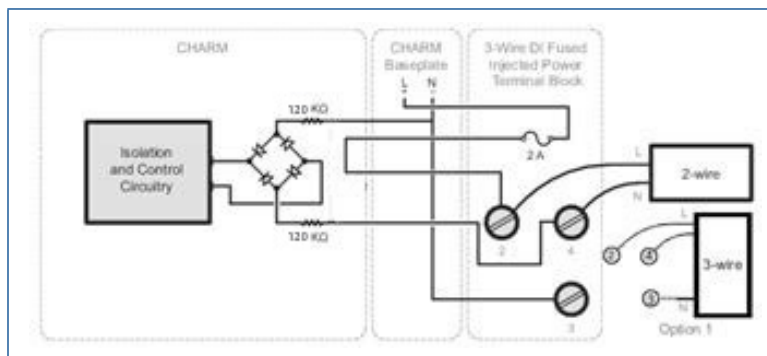

Simplified Circuit and Connection Diagrams for DI 230V AC Isolated CHARM with 3-wire DI Fused-Injected-Power Terminal Block.

Discrete Output V AC Isolated CHARM

Specifications for DO V AC Isolated CHARM	
Sensor Types	V AC Inductive load
Output Range	20 to 250V AC
Output Rating	0.5 A continuous (10 A inrush for <20 ms, 2.5 A inrush for <100 ms)
Off State Leakage Current	2 mA maximum at 120V AC 4 mA maximum at 230V AC
Configurable Output Behavior	<ul style="list-style-type: none"> ■ Momentary Output ■ Continuous Pulse Output
Isolation	Each channel is optically isolated from the system at 250V AC
Field Circuit Protection	<ul style="list-style-type: none"> ■ Field wiring disconnect ■ Recommend external fuse at power source
CHARM Power Req.	12 mA max @ 24V DC
CHARM Heat Dissipation	0.70 W

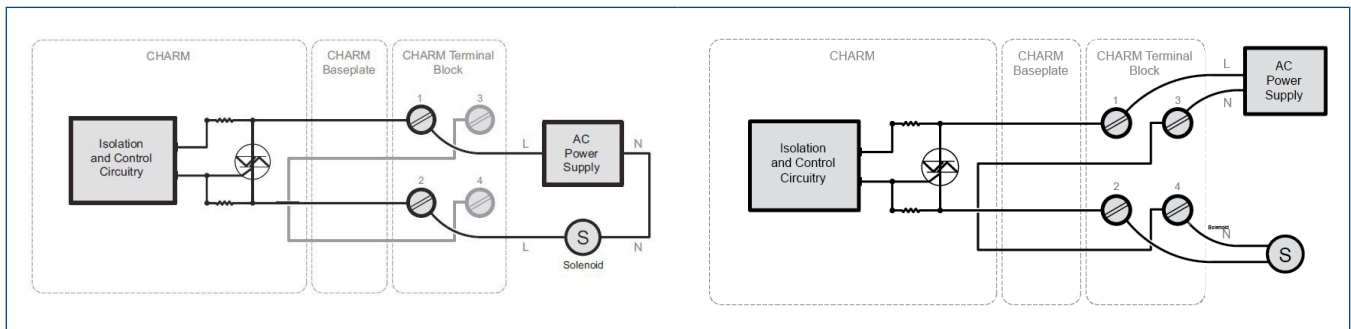

Simplified Circuit and Connection Diagrams for DO V AC Isolated CHARM.

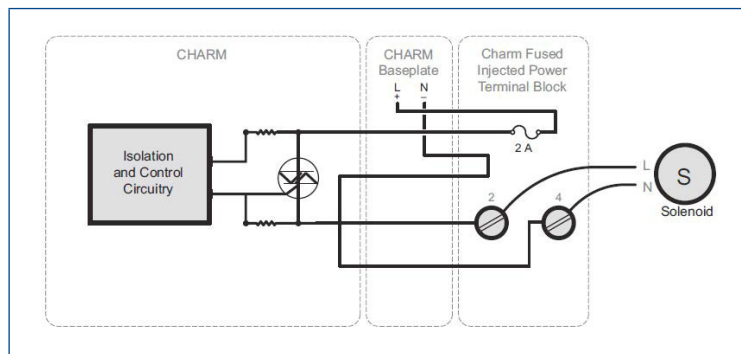

Simplified Circuit and Connection Diagrams for DO V AC Isolated CHARM with Fused-Injected-Power Terminal Block.

ASCO Numatics 580 CHARM Node

Specifications for ASCO Numatics 580 CHARM Node	
Bus Power	6.3V DC at 100mA
Valve Power	24V DC at 1.07A
Power and Bus Connector	A-Coded 5 Pin M12 Male
LEDs	Module Status and Network Status
Operating Temperature Range	-10 to 115°F (-23 to 46°C)
Operating Humidity	95% Relative Humidity, Non-condensing
Vibration Shock	EC 60068-2-27, IEC 60068-2-6
Moisture	IP65 Certified
Maximum Valve Solenoid Outputs	96
Diagnostics	Power, short, open load conditions are monitored
More information	https://www.emerson.com/en-gb/catalog/aventics-580-charm-en-gb*

*For hazardous area installations, please refer to installation instructions from ASCO.



580 CHARM Node.

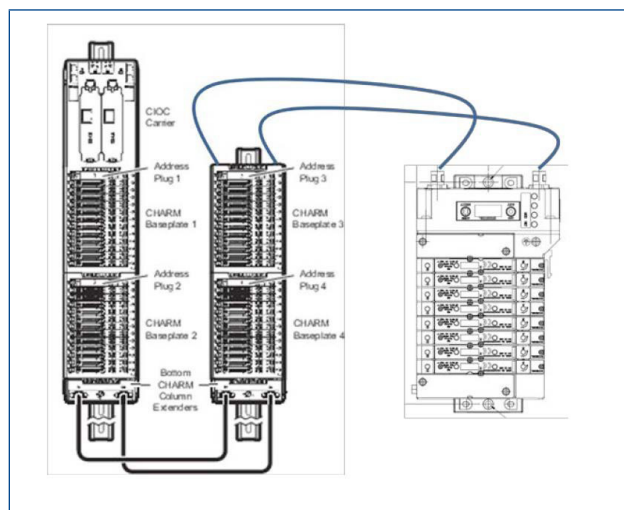

Connection to DeltaV Electronic Marshalling.

System Compatibility

CHARM I/O hardware requires:

- SD Plus controllers with DeltaV v11.3.1 or later software
- SX Controllers with DeltaV v11.3.1 or later software
- SQ Controllers with DeltaV v11.3.1 or later software
- MD Plus Controllers with DeltaV v14.3 or later software
- MQ Controllers with DeltaV v14.3 or later software
- MX Controllers with DeltaV v14.3 or later software
- PK Controllers with DeltaV v14.3 or later software

When assigning CHARMs to MD Plus and SD Plus controllers, make sure to evaluate the Time Utilization Chart on the controller in DeltaV Diagnostics to ensure the additional communication load can be handled by the controller.

S-series and M-series controllers can be installed on the same DeltaV Area Control Network in v11 and beyond. PK Controllers can be installed on the same DeltaV Area Control network in v14.3 and beyond.

Control modules can be assigned to any controller and inter-controller references are fully supported between different types of controllers.

Certifications

The following certifications are available for DeltaV Electronic Marshalling (see actual certificates for exact certifications for each product):

■ CE

EMC - EN 61326-1

■ FM

FM 3600

FM 3611

■ CSA

CSA C22.2 No. 213-M1987

CSA C22.2 No. 61010-1

■ ATEX

EN60079-0

EN60079-7

EN60079-15

■ IEC-Ex

IEC60079-0

EN60079-7

IEC60079-15

■ Marine Certifications

IACS E10

ABS Certificate of Design Assessment

DNV Marine Certificate

■ Achilles Communications Certification

CIOC: Level 1 (v13.3.1, v14.FP1)

CIOC2: Level 2 (v14.3, v14.FP1)

Hazardous Area/Location

DeltaV Electronic Marshalling solutions can be installed and used based on the following Standards: (see actual certificates for exact product markings for each product)

■ FM (USA)

Class I, Division 2, Groups A, B, C, D, T4

Class 1, Zone 2:

AEx ec IIC Gc T4

AEx ec nC IIC T4

AEx ec [ic] IIC Gc T4

AEx ec ic IIC Gc T4

■ cFM (Canada)

Class I, Division 2, Groups A, B, C, D, T4

Class 1, Zone 2

Ex ec IIC Gc T4

Ex ec nC IIC Gc T4

Ex ec [ic] IIC Gc T4

Ex ec ic IIC Gc T4

■ **ATEX**

- II 3G Ex ec IIC T4 Gc
- II 3G Ex ec [ic] IIC T4 Gc
- II 3G Ex ec ic IIC T4 Gc
- II 3G Ex ec nC IIC T4 Gc

■ **IEC-Ex**

- II 3G Ex ec IIC T4 Gc
- II 3G Ex ec [ic] IIC T4 Gc
- II 3G Ex ec ic IIC T4 Gc
- II 3G Ex ec nC IIC T4 Gc

Class 1 Division 2 Installation Instructions CHARM Subsystem 12P5401

Class 1 Division 2 Installation Instructions DeltaV S-Series 12P5402

Zone 2 Installation Instructions CHARM Subsystem 12P5403

Zone 2 Installation Instructions DeltaV S-Series 12P5404

Ordering Information

CHARM I/O Cards and Carrier	
Description	Model Number
Redundant CIOC2 with Copper Ethernet, includes redundant pair of CHARM I/O Card 2, CHARM I/O Carrier with Screw Terminals, Copper I/O Ports, a Baseplate Identifier and a Baseplate Separation Wall	SE6505T01*
Redundant CIOC2 with fiber optics Ethernet, includes redundant pair of CHARM I/O Card 2, CHARM I/O Carrier with Screw Terminals, Fiberoptic I/O Ports, a Baseplate Identifier and a Baseplate Separation Wall	SE6505T02
Redundant CIOC Carrier Assembly with Copper Ethernet, includes CHARM I/O Carrier with Screw Terminals, Copper I/O Ports, a Baseplate Identifier and a Baseplate Separation Wall	SE6501T05*
Redundant CIOC Carrier Assembly with fiber optics Ethernet, includes CHARM I/O Carrier with Screw Terminals, Fiberoptic I/O Ports, a Baseplate Identifier and a Baseplate Separation Wall	SE6501T06
Redundant CIOC2, includes 2 CHARMs I/O Card 2, (Order these with standard cabinets)	SE6504
CHARM Baseplates Assemblies	
Description	Model Number
CHARMs Baseplate Assembly, includes CHARMs Baseplate, CHARM Address Terminal Block with Screw Terminals, 12 Standard CHARM Terminal Blocks and a Baseplate Identifier	SE4601T07
CHARMs Baseplate Assembly with 3-wire DI Fused Fused-Injected-Power, includes CHARMS Baseplate, CHARM Address Terminal Block with Screw Terminals, 12 3-wire DI Fused-Injected-Power CHARM Terminal Blocks and a Baseplate Identifier	SE4601T09
CHARMs Baseplate Assembly with Fused-Injected Field Power, includes CHARMS Baseplate, CHARM Address Terminal Block with Screw Terminals, 12 Fused-Injected-Power CHARM Terminal Blocks and a Baseplate Identifier	SE4601T08
CHARMs Baseplate Assembly with Relay Output, includes CHARMS Baseplate, CHARM Address Terminal Block with Screw Terminals, 12 Relay Output CHARM Terminal Blocks and a Baseplate Identifier	SE4601T05

CHARM I/O Baseplate Address Plugs	
Description	Model Number
CHARMs Addressing Plugs, includes Address Plugs 1 through 8	SE4602
CHARMs Addressing Plugs, includes Address Plugs 1 through 4	SE4613

*The copper IOPs in this bundle are only supported in v13.3.1 and later and doesn't have DNV marine certifications yet. If ABS marine certification is not sufficient or if it is intended to be used for earlier versions, please request KL1601X1-BA1 and order the CIOC Carrier as KL4101X1-BA1. Each vertical DIN rail requires a DIN Rail stop to lock baseplates in position. Order VE4054DRS, which is a box of 5.

Ordering Information

CHARM I/O Baseplate Extender and Terminator	
Description	Model Number
CHARMs Baseplate Extender with Cable Connectors, Top (Male) includes a Baseplate Identifier and a Baseplate Separation Wall	SE4603T05
CHARMs Baseplate Extender with Cable Connectors, Bottom (Female) includes a Baseplate Identifier and a Baseplate Separation Wall	SE4603T06
CHARMs Baseplate Terminator, Top (Male) includes a Baseplate Identifier and a Baseplate Separation Wall	SE4604T03
CHARMs Baseplate Terminator, Bottom (Female) includes a Baseplate Identifier and a Baseplate Separation Wall	SE4604T04

CHARM I/O Baseplate Extender Cables	
Description	Model Number
CHARMs Baseplate Cables , includes two 0.5 m cables	SE4605T02
CHARMs Baseplate Cables , includes two 1 m cables	SE4605T03
CHARMs Baseplate Cables , includes two 2 m cables	SE4605T04

Each vertical DIN rail requires a DIN Rail stop to lock baseplates in position. Order VE4054DRS, which is a box of 5.

Low Voltage Instrumentation CHARMS	
Description	Model Number
DI NAMUR	SE4301T01
DI 24V DC Low-Side Sense (Dry Contact)	SE4301T02
DI 24V DC Isolated	SE4301T07
DO 24V DC High-Side	SE4302T01
DO 24V DC Isolated	SE4302T02
DO 24V DC 100mA Energy Limited	SE4302T04
24V DC Power	SE4302T05
AI 4-20 mA HART	SE4303T01
Thermocouple/mV Input	SE4303T02
RTD Input	SE4303T03
AI 0-10V DC Isolated	SE4303T04
AO 4-20 mA HART	SE4304T01

Ordering Information

High Voltage Instrumentation CHARMS	
Description	Model Number
DI 120V AC Isolated	SE4301T03
DI 120V AC Isolated Plus	SE4301T05**
DI 230V AC Isolated	SE4301T04
DO V AC Isolated	SE4302T03

Low Voltage Instrumentation CHARMS and Terminal Block Assemblies	
Description	Model Number
DO 24V DC High-Side CHARM with Relay Output Terminal Block	SE4302T51
Thermocouple/mV Input CHARM with Thermocouple/mV Terminal Block	SE4303T52
24V DC Power CHARM with Fused-Injected-Power Terminal Block	SE4302T55*

*24V DC Power CHARM requires DeltaV v12.3 or later software to be able to configure and use the diagnostic Information.

**The DI 120V AC Isolated Plus CHARM requires a HotFix to be used with DeltaV v11.3.1 and v12.3.1.

Additional Ordering Information for Protection Cover and Terminal Blocks

Protection Cover (fits all terminal blocks)	
Description	Model Number
CHARM Protection Cover; Package of 12	SE6103
Terminal Blocks	
Description	Model Number
Standard CHARM Terminal Block	SE4501
3-wire DI Fused-Injected-Power Terminal Block	SE4512
Fused-Injected-Power Terminal Block	SE4502
Relay Output Terminal Block	SE4503
Thermocouple/mV Terminal Block	SE4504
3-wire AI Fused Injected Power Terminal Block	SE4511

CHARM I/O Labeling and Spare Part Ordering Information

CHARM I/O Labeling and Spare Parts	
Description	Model Number
Channel Identifier Labels for CHARM Baseplates; Package of 8	SE4606T02
Charm Baseplate Identifier; Package of 9	SE4606T03
Power Terminal Plug for CHARM I/O Carrier	KJ4005X1-BF1
250V 2A Fuse for Fused Terminal Block; Box of 20	KJ4010X1-BC1
I/O Port Switch Module; Copper; for CIOC Carriers	KL1601X1-BB1*
I/O Port Switch Module; Fiber; for CIOC Carriers	KL1602X1-BA1**

*Doesn't have DNV marine certification yet and is only supported on v13.3.1 and later. If ABS marine certification is not sufficient or replacement is needed for earlier versions, please request KL1601X1-BA1.

**Fiber optic Ethernet I/O Ports are not cascadeable.

ASCO Numatics Series 580 CHARM Node

ASCO Numatics Series 580 CHARM node parts	
Description	ASCO Part Number
580 CHARM node	Contact ASCO*
580 CHARM Power and Communication Cable Set 2 Cables, 1.5 M Length, with M12 and sub-D connectors	Contact ASCO*

*Requires hotfix for DeltaV v11.3.1, v12.3.1, and v13.3. Sold directly from ASCO, please see more detail at <https://www.emerson.com/en-gb/catalog/aventics-580-charm-en-gb>.

Related Products

DeltaV Electronic Marshalling with Distributed CHARMS

Prerequisites

DeltaV Electronic Marshalling hardware requires DeltaV v11.3.1 or later software. Assigning CHARMS to MD Plus, MQ, MX, and PK Controllers is supported in DeltaV v14.3 and later, but is not supported on M-series Controller Interfaces to PROVOX and RS3.

CHARM I/O Card 2 (CIOC2) requires DeltaV v13.3.1 or later software. Hotfix is required for v13.3.1 and v13.3.2.

Electronic Marshalling requires use of DeltaV Smart Switches between controllers and CIOCs, please refer to Network Considerations for M-series with Electronic Marshalling White Paper when adding Electronic Marshalling to M-series systems.

©2024, Emerson. All rights reserved.

The Emerson logo is a trademark and service mark of Emerson Electric Co. The DeltaV logo is a mark of one of the Emerson family of companies. All other marks are the property of their respective owners.

The contents of this publication are presented for informational purposes only, and while diligent efforts were made to ensure their accuracy, they are not to be construed as warranties or guarantees, express or implied, regarding the products or services described herein or their use or applicability. All sales are governed by our terms and conditions, which are available on request. We reserve the right to modify or improve the designs or specifications of our products at any time without notice.

Contact Us

www.emerson.com/contactus