

A large-scale photograph of an offshore oil rig at sunset. The rig's complex steel structure is silhouetted against a bright orange and yellow sky. The rig is situated on a dark, choppy sea. In the upper left, a crane is visible. The overall scene conveys a sense of industrial scale and reliability.

**Lightweight, Efficient and
Reliable - All in a Compact,
Modular Package**

G-Series Pneumatic and Hydraulic Actuators

Next Generation Actuation Technologies Solutions





Bettis™ G-Series
with Wireless Transmitter

Emerson sets the standards for innovation and quality in pneumatic and hydraulic valve automation

Lightweight, efficient and reliable - all in a compact, modular package

Available with either symmetric or canted yokes to suit your operating requirements



Bettis™ G-Series
with Topworx™ Positioner

Design and Construction

Emerson, a leading pioneer in the valve automation and control industry for more than 55-years, has developed numerous innovations that have become today's industry standards. With continued focus on ingenuity, reliability, quality and product safety, our entire product offering is considered to be the global standard for automating valves in the oil & gas, power generation, pulp and paper, petrochemical, chemical, wastewater, and numerous other process industries. Performance has been the main differentiator. Emerson is recognized for effectiveness and reliability in some of the world's most difficult operating environments.

G-Series pneumatic and hydraulic actuators provide the latest in valve actuation design. A highly unique and reliable means for operating ball, butterfly or plug valves along with louvers, dampers and other 90 degree rotating mechanisms, the G-Series carries an industry leading five-year warranty on materials and workmanship.

G-Series Application And Features

- PED 2014/68/EU compliant to meet the stringent requirements of pressure mounting vessels
- Meets both IP66 and IP67M specifications for submergence and high pressure water deluge test. Offers superior water ingress and corrosion protection
- Suitability for use within the demanding applications of a SIL environment
- Available in both spring-return or double-acting configurations and can operate with either a symmetric or canted yoke
- Offers multiple configurations, with a modular design that enables safe field maintenance and reduced inventory costs
- More compact than other actuators of equal torque output – 1/3 lighter and 1/2 smaller
- Interchangeable power and spring modules for quick reversal of the fail-safe mode
- Close Loop Instrument System for actuators **should always be used** for the following applications: high humidity, salt air, corrosive dust, inks and dyes, wash downs. The closed loop system routes the operating media being exhausted from the power side of the cylinder to the vented side of the cylinder. Maximum pressure on the vented side of the power cylinder is to be 5 to 8 psig
- 5-Year Warranty



Operating Ranges

G-Series has guaranteed torque outputs for spring-return models in excess of 3,000,000 lb-in (339,000 Nm) and double-acting 12,581 – 6,000,000 lb-in (1420 – 678,000 Nm). Operating pressures are:

Pneumatic – 40-220 psig (3-14 Bar)
Hydraulic – to 5,000 psig (345 Bar)

Standard Trim	High Temp. Trim (-10)	Low Temp. Trim (-11)	
None-PED and PED		None-PED	PED
-20°F to +200°F	0°F to +350°F	-40°F to +150°F	Consult Factory
-29°C to +93°C	-18°C to +177°C	-40°C to +66°C	

Reduces Wear

The Powr-Swivl™ piston rod and guide block connection compensates for side load deflection and reduces wear. Seal-lubricating bearings protect sliding and rotating components.

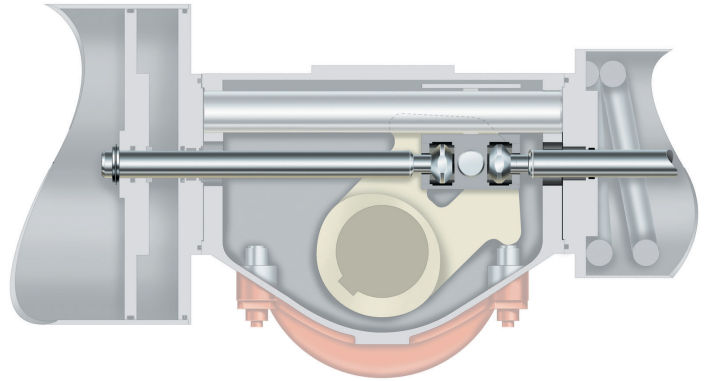

Powr-Swivl™

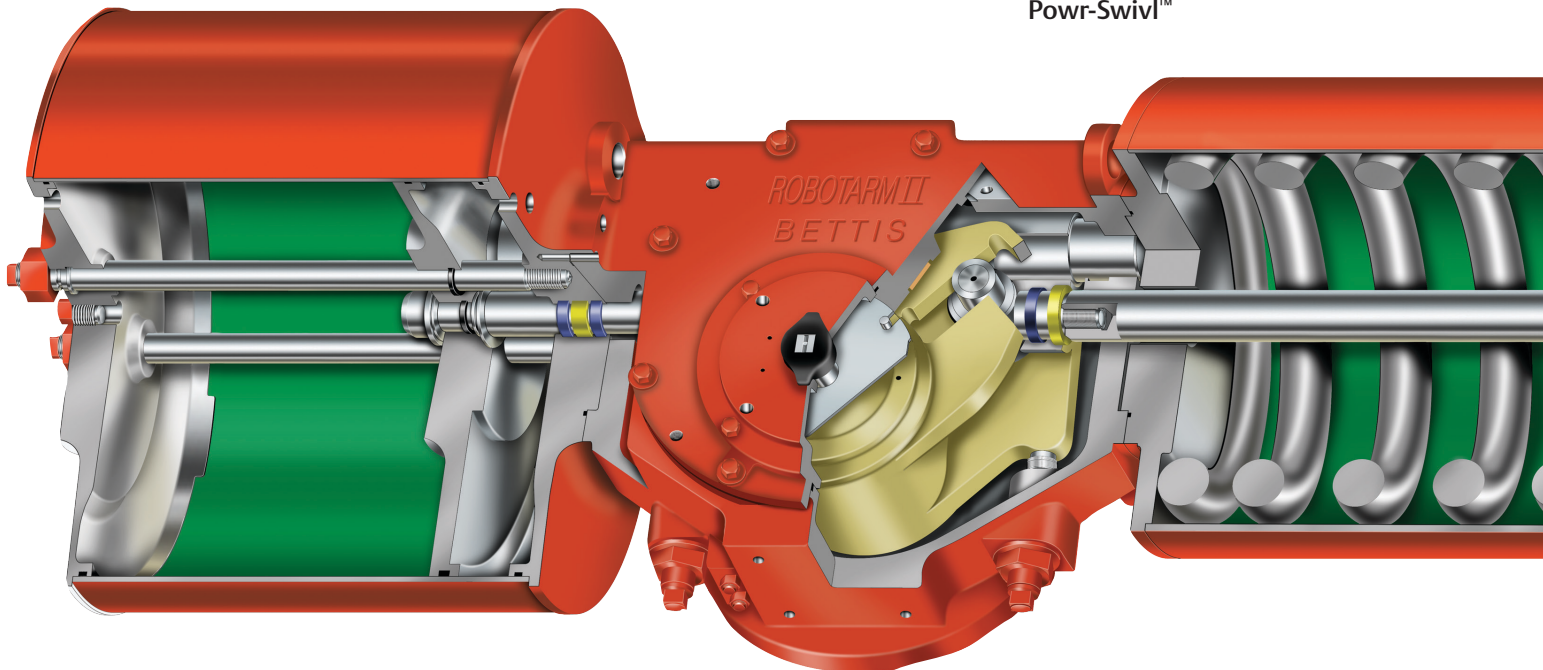

Promotes Safety

The patented Tension-Lok™ device positively locks the spring module to allow its safe removal and installation, eliminating accidental release of the spring force.

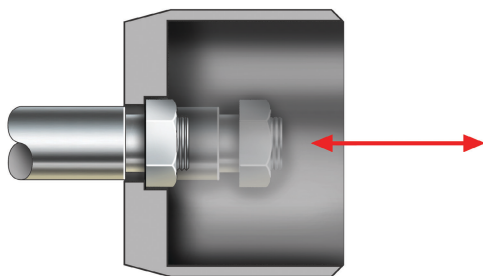

Tension-Lok™

Resists Corrosion

Tie-bars on pneumatic power modules are corrosion resistant, and internal and external surfaces are coated to protect in harsh environments.

Seals Positively

With dual drive module vent checks, breather seals, total O-ring sealing and no gaskets, the G-Series prevents water ingress and seals out the environment.

Bidirectional Travel Stops

Integral bidirectional travel stops, adjustable from 80° to 100° of total valve travel, assist G-Series in prolonging valve seat integrity.

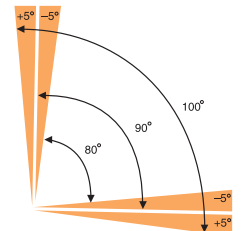

Other G-Series Actuation Solutions

GS-Series

Emerson actuators have long been a preferred brand for use in marine environments. GS-Series actuators are well suited for splash zone, riser and other offshore fail-safe applications. They are available with diver or ROV intervention systems.

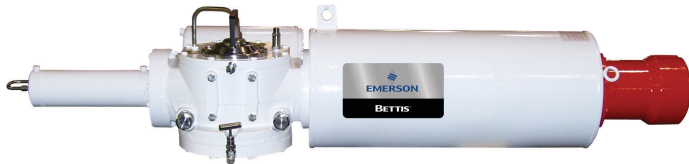

NG-Series

NG-Series actuators have been independently tested to include LOCA (Loss of Cooling Accident), meets IEEE 382 standards, seismic, and various aging processes required to meet current nuclear qualification criteria.

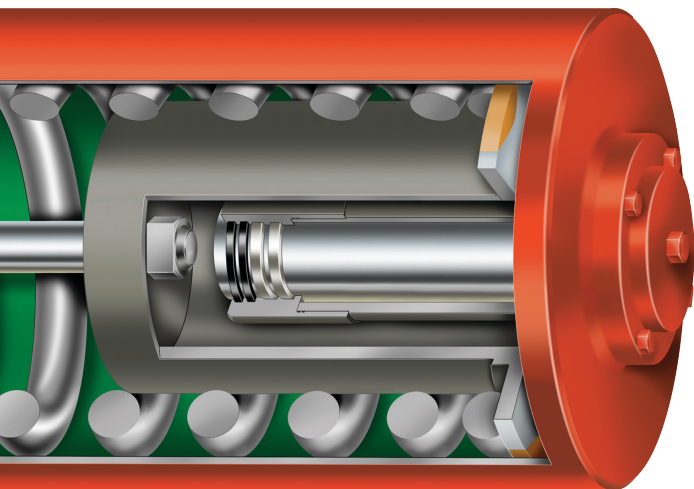

GH-Series

The GH-Series actuators provide specialized higher maximum operating pressures (MOP) where required. Available in either canted (model GHC) or symmetric (GH) yoke configurations for spring-return, fail-safe projects. An optional SRO spring is available for higher spring start and end torques.

Safety Integrity Level (SIL)

G-Series actuators are well suited for demanding SIL applications. These actuators have a Failure Modes and Effects Diagnostics Analysis (FMEDA) capability with reporting performed through Exida.com™ for SIL suitability. When a Fisher™, TÜV-certified FIELDVUE® controller is added to the G-Series, it is capable of partial stroke testing and providing continuous monitoring of supply pressure, valve position and pressure values to verify proper working condition. The G-Series then becomes an integral component in controlling the final control element in SIL 1, 2 or 3 applications.

Jackscrew is available for the G1, G2, and G3

Offered in a variety of mechanical and manual overrides, the G-Series with the M11 hydraulic override may also be used with either spring-return pneumatic or hydraulic models. The M3 jackscrew manual override for G1, G2, and G3 models is available with or without handwheel.

Symmetric or Canted Yokes

G-Series actuators available with either symmetric or canted yokes. Traditional symmetric yokes provide efficient operation at both the break and end positions. Canted (or inclined) yokes have a torque advantage in applications where higher break torque is needed to unseat the valve, with less critical needs at the run or full open positions.

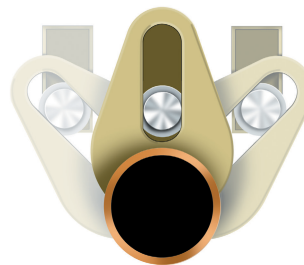
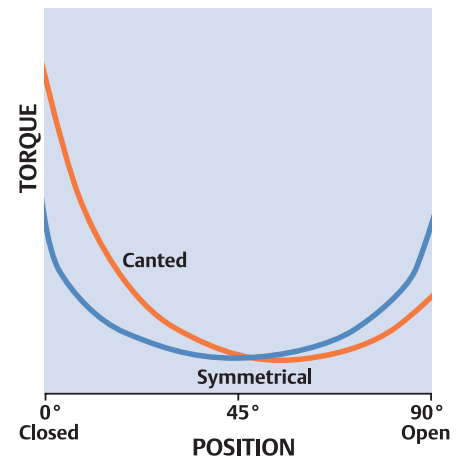

Symmetric Yoke

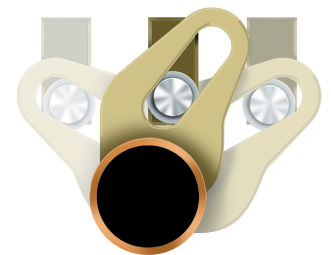

Canted Yoke

Other Emerson controls and accessories:

Fisher™

- Digital Valve Controllers
- Positioners
- Regulators

TopWorx™

- Switch Boxes
- Wireless Position Monitoring

ASCO Numatics™

- Solenoid Valves

For more detailed technical information go to our online documentation at www.emerson.com/en-us/catalog/automation-solutions/bettis-sku-g-series-pneumatic

Options

Overrides

Emerson offers a variety of mechanical and manual overrides for G-Series models. The M11 hydraulic override can be used with either spring-return pneumatic or hydraulic models. The M3 jackscrew manual override for G1, G2 and G3 models is available with or without handwheel. The G-Ride (shown) is an economical external non-declutchable mechanical override for G4 and G5 spring-return models available with standard hex nut or handwheel.



Automated Valve Packages

Emerson offers complete valve operating systems for final valve control. At our World Area Configuration Centers (WACC), we combine the G-Series actuator, controls and a valve in a single system. We can integrate a complete controls offering including world-class PlantWeb® digital plant architecture. We also supply BettisSystems™, pre-engineered and documented controls packages, available at our WACC reducing lead times, simplifying purchasing and installation.

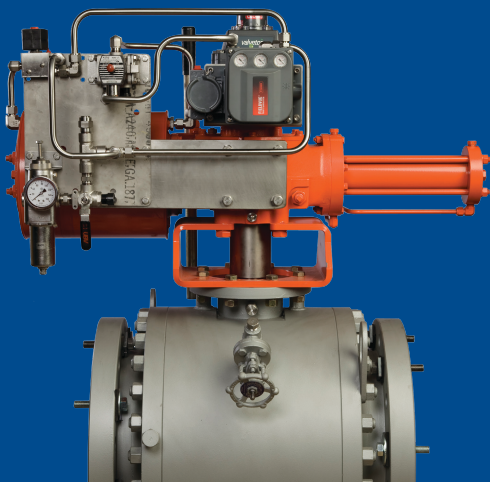

Modular Versatility

- Enables Online Field Maintenance
- Lowers Inventory

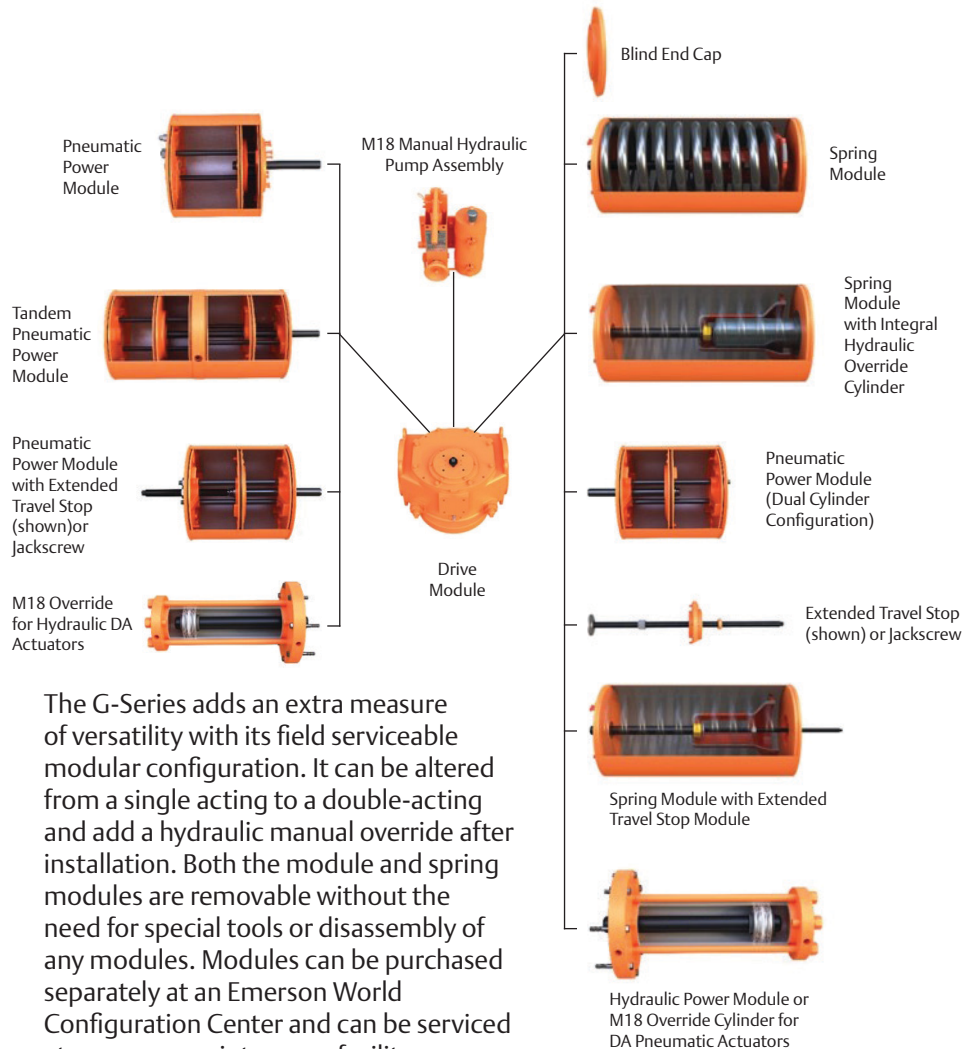

The G-Series adds an extra measure of versatility with its field serviceable modular configuration. It can be altered from a single acting to a double-acting and add a hydraulic manual override after installation. Both the module and spring modules are removable without the need for special tools or disassembly of any modules. Modules can be purchased separately at an Emerson World Configuration Center and can be serviced at your own maintenance facility.

Note: The above graphic is for illustration purposes only. Please consult factory for certified dimensional drawings.

Standards and Certifications

G-Series actuators are manufactured to meet the following worldwide quality and safety standards:



ISO-9001



ABS

PED 2014/68/EU –
Pressure
Equipment
Directive

Shell DEP 2016 Compliance

World's very first complete actuator product line that successfully passed stringent "Shell Endurance Test" per Shell DEP 2016 and EN15714-3 Standard. The test was supervised and monitored by Shell and Lloyd agency throughout and the final result was certified by Shell Projects & Technology PACO Principal Technical Expert.

World Area Configuration Centers (WACC) offer sales support, service, inventory and commissioning to our global customers. Choose the WACC or sales office nearest you:

NORTH & SOUTH AMERICA

19200 Northwest Freeway
Houston TX 77065
USA
T +1 281 477 4100

Av. Hollingsworth
325 Iporanga Sorocaba
SP 18087-105
Brazil
T +55 15 3413 8888

ASIA PACIFIC

No. 9 Gul Road
#01-02 Singapore 629361
T +65 6777 8211

No. 1 Lai Yuan Road
Wuqing Development Area
Tianjin 301700
P. R. China
T +86 22 8212 3300

Floor 4, B10
No. 10 Jiuxianqiao Road
BOE Universal Business Park
Beijing 100015
P. R. China
T +86 10 8572 6666

MIDDLE EAST & AFRICA

P. O. Box 17033
Jebel Ali Free Zone
Dubai
T +971 4 811 8100

EUROPE

Holland Fisor 6
Székesfehérvár 8000
Hungary
T +36 22 53 09 50

Strada Biffi 165
29017 Fiorenzuola d'Arda (PC)
Italy
T +39 0523 944 411

This product is only intended for use in large-scale fixed installations excluded from the scope of Directive 2011/65/EU on the restriction of the use of certain hazardous substances in electrical and electronic equipment (RoHS 2).

For complete list of sales and manufacturing sites, please visit www.emerson.com/actuationtechnologieslocations or contact us at info.actuationtechnologies@emerson.com

©2022 Emerson. All rights reserved.

The Emerson logo is a trademark and service mark of Emerson Electric Co. Bettis™ is a mark of the Emerson family of companies. All other marks are property of their respective owners.

BETTIS™

www.emerson.com/bettis

