

# Rosemount Instrumentation for the Power Industry



Measurement Technologies to Power the Future

**ROSEMOUNT**<sup>®</sup>

  
**EMERSON**<sup>™</sup>  
Process Management

## Optimize Your Resources: From Project Planning Throughout the Life of Your Plant

*Emerson Process Management offers a winning combination of best-in-class technologies and engineering expertise to help you power the future. With 50 years of experience and over a million devices installed in power generation plants around the world, we are uniquely qualified to provide the products and expertise necessary to help you succeed. Rosemount pressure, temperature, level, and flow measurement technologies can reduce the project execution cycle and lower capital expenditures. Throughout the life of your plant, we'll help you improve uptime, lower generation costs, minimize fuel costs, and enhance environmental compliance.*

## A Business Partner You Can Trust

Emerson Process Management has an extensive global network of factory-certified Instrument Consultants. These experts act locally to support your needs and implement solutions that deliver results. Our project teams are uniquely qualified to ensure Rosemount technologies are implemented to achieve optimal results.

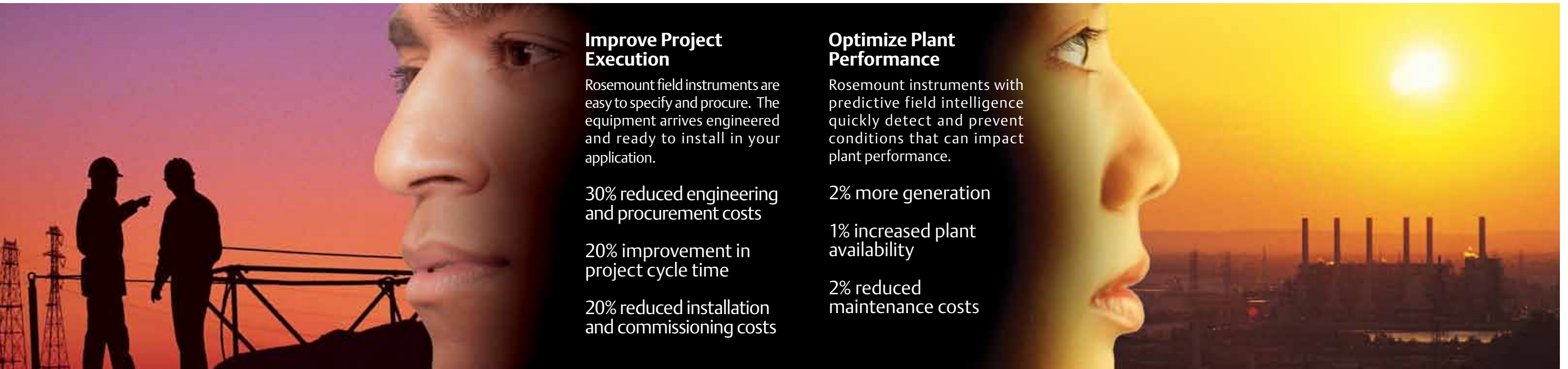

<b>Improve Project Execution</b>	<b>Optimize Plant Performance</b>
Rosemount field instruments are easy to specify and procure. The equipment arrives engineered and ready to install in your application.	Rosemount instruments with predictive field intelligence quickly detect and prevent conditions that can impact plant performance.
30% reduced engineering and procurement costs	2% more generation
20% improvement in project cycle time	1% increased plant availability
20% reduced installation and commissioning costs	2% reduced maintenance costs

## The Best Instrument for Your Application

Our consultative approach, based on best measurement practices, helps optimize performance in each application. We combine our proven Rosemount technology and experience with best practices to give you a competitive advantage. Our global sales force understands your business requirements and is available to help you determine which Rosemount product will deliver the best results.

## Reliable Technologies to Optimize Your Plant

Innovative Rosemount technologies, which power Emerson's PlantWeb® digital plant architecture, are your blueprint for improving startup and optimizing plant performance. Green-field facilities benefit from lower capital expenditures, while existing plants take advantage of an architecture that delivers drastically reduced operational expenditures.

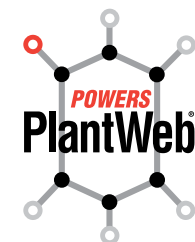

## Improved Project Execution



**“I’ve got to reduce my capital costs and execute my project on schedule, all while minimizing my risk. I need a reliable partner.”**

Save on design and procurement expenditures. Rosemount instruments leverage best engineering, installation, and commissioning practices to reduce installation costs and shorten schedules. Our global manufacturing facilities deliver best-in-class Rosemount products when you need them, where you need them. Rosemount instrument consultants can specify the best products and practices to meet your project requirements and business needs.

The Rosemount MultiVariable™ family of products provides increased measurement capability with every installation. This results in less infrastructure, lower procurement costs and faster commissioning.



The Rosemount Conditioning Orifice Plate significantly lowers material, labor and procurement costs by reducing straight run requirements, engineering time, and vendor sources.

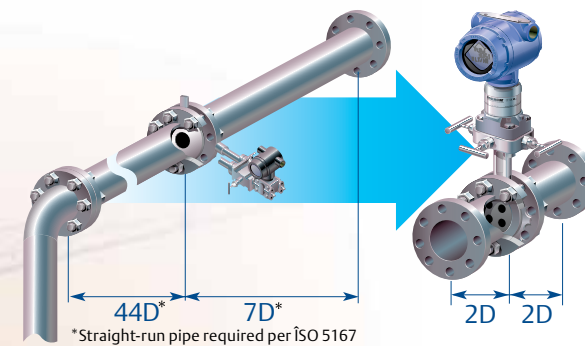

## Optimized Plant Performance



**“Generating additional megawatts is critical for my operation.”**

Operate your plant at maximum capacity. The industry-leading performance of Rosemount instruments reduces process variability through faster response to changing variables and accurate compensation in real world conditions.

All gas and steam flows have pressure and temperature variations that significantly degrade flow performance. Real-time compensation from Rosemount MultiVariable sensing technology virtually eliminates this impact.

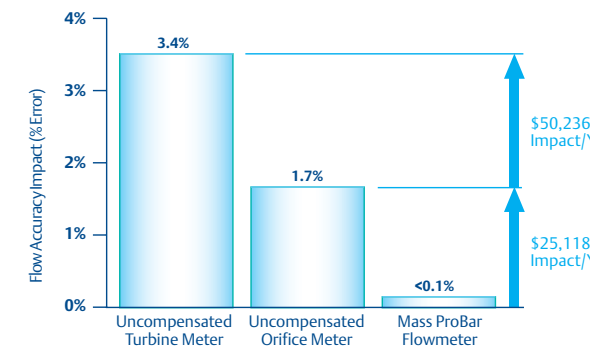

**“Reducing the cost of generation is a priority for my company.”**

Keep your plant running at maximum efficiency. The quality designed and built into each Rosemount product delivers unparalleled reliability and stability. With long service life and extended calibration intervals, Rosemount instruments can help you optimize your operation and lower the cost of generation.

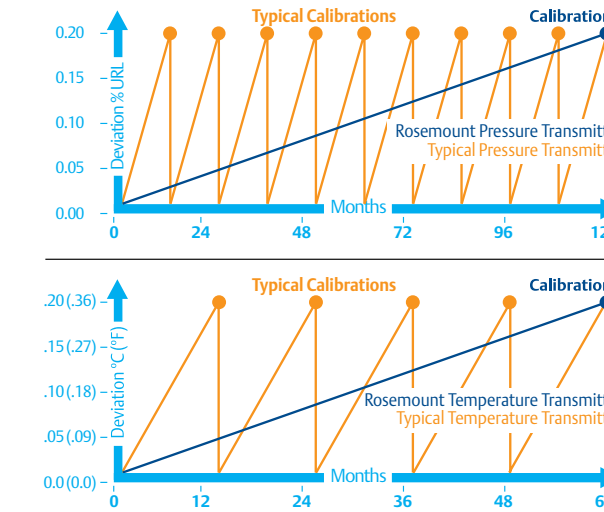

Rosemount products feature world-class device stability. Performance is maintained over time and calibration intervals are reduced. Maintenance practices move from reactive to set-and-forget.

**“I can’t afford interruptions in power generation.”**

Ensure operation through periods of peak energy demand. The process and device diagnostics in Rosemount transmitters help predict abnormal conditions. PlantWeb alerts communicate process and device health to avoid unscheduled shutdowns, moving you from reactive to predictive maintenance.

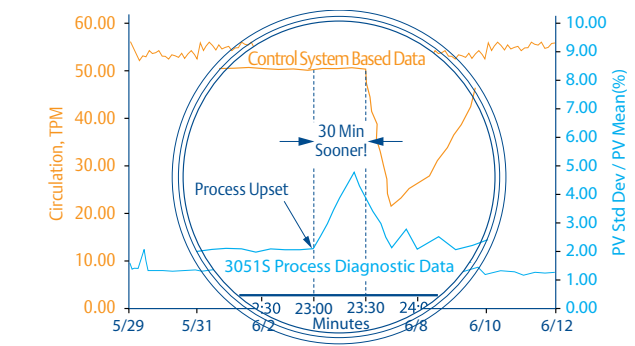

Statistical Process Monitoring Diagnostics can detect a process change up to 30 minutes earlier than a conventional distributed control system. This can help avoid major process upsets that could lead to reduced efficiency, or plant shutdown.



Eliminate the maintenance headaches and downtime associated with troublesome impulse lines. Rosemount flowmeters feature direct mounting for greater reliability and reduced process variability.

The Rosemount remote display and interface provides easy at-grade access to diagnostic information.



**“My facility is working hard to be safer and greener.”**

Safety, health, and environment are top priorities. Rosemount instrumentation can prevent unsafe conditions in your plant through process alerts, certified devices, and best installation practices.

Maximizing tank capacity without risk of hazardous spillage and overflow can be obtained with a combination of top-down radar technology and level switches. Rosemount radar gauges offer a precise level measurement independent of fluid properties, allowing the vessels to be safely filled to high levels. Rosemount level switches are available to add another layer of protection against overfills.



# Proven Installation Practices in Power Applications

## Superheated Steam Flow

Operate boiler systems at optimum efficiency, especially under fluctuating power demands.



Rosemount 3051SFA Probar® Flowmeter

The Rosemount Main Steam Line Annubar® withstands the rigors of extreme temperatures, up to 1200°F (649°C), and pressures up to 3000 psig (207 bar), while maintaining better than 1% flow accuracy.

- Easy insertion installation minimizes cost and reduces special test requirements
- Lowest permanent pressure loss
- Rugged construction in a wide range of materials

## Drum Level

Reliable measurement and control of drum level prevents overflow of water to the turbine and ensures boiler uptime.



Rosemount 3051S Series of Instrumentation

The Rosemount 3051S transmitter with unprecedented accuracy of 0.025% and 10-year stability provides the most reliable and accurate drum level control.

- Long trouble-free operation
- Self diagnostics and programmable process alerts help prevent boiler trips

## Main Steam Temperature

Accurately and continuously control main steam temperature to increase boiler heat rate, extend turbine life and reduce tube wear.



Rosemount 3144P, 644 Temperature Transmitters

Dual sensor MultiVariable temperature transmitters measure steam temperature accurately without interruption. The Hot BackUp® feature protects investment and maximizes availability by automatically switching to a backup sensor should the primary sensor fail.

## Total Air Flow

Reduce excess air into the boiler to optimize the fuel/air ratio in the combustion process.



Rosemount 3095MFA Mass Probar Flowmeter

Rosemount Annubar installations provide maintenance-free, accurate and repeatable total air flow measurement to optimize combustion control and maintain optimum fuel/air ratio.

- Suitable for large duct sizes
- 10:1 turndown maintains optimum combustion air at low loads
- Easiest installation and maintenance

## Furnace Pressure

Ensure safe and efficient boiler operation through better control of furnace draft.



Rosemount 3051C Pressure Transmitter

Rosemount draft range transmitters accurately measure low pressures and eliminate harmful positive furnace pressure excursions. Negative pressure is restricted to desired set point range.

- Reduced process variability, tighter set point control
- Diagnostics and user-defined process alerts help prevent potential mechanical malfunctions in fans and dampers

## Saturated Steam Flow

Efficiently and accurately calculate thermal cycle efficiency and auxiliary steam consumption.



Rosemount 3095MFA Mass Probar Flowmeter

The combination of MultiVariable sensing technology and continuous real-time compensation eliminates the effect of pressure and temperature variations that degrade flow accuracy.

- ±0.9% flow accuracy up to 10:1 turndown
- Single pipe penetration delivers flow, differential pressure, pressure and temperature measurement

## Heater Vessel Level

Optimize heat exchanger performance and continuous condensate level control.



Rosemount 3300 Radar Level Transmitter

Guided Wave Radar is immune to density changes and high vibrations. It can be used to replace displacer transmitters in both vacuum and high pressure heater vessels, eliminating maintenance and calibration.

## Natural Gas Flow

Determine gas turbine efficiency accurately under all load conditions and continuously meter gas consumption.



Rosemount 3095 Engineered Assembly

Rosemount Engineered Assembly flowmeters are custom designed in compliance with all applicable standards, including weld certifications and third-party calibrations, if required. Each unit is assembled, configured, leak tested and ready-to-install.

## Pump Bearing Temperature

Increase service life of rotating equipment bearings and reduce maintenance costs.



Rosemount 248R Temperature Transmitter

Rail mounted temperature transmitters with Button Probe Bearing Sensors offer the most economical and reliable complete point bearing temperature measurement solution.

- Sensors are rugged and sustain high vibration
- Compact and flexible
- No thermowells required; direct oil dipped

## Solids Level

Provide continuous coal supply to boiler. Monitor fly ash levels to prevent spillage.



Rosemount 5600 Radar Level Transmitter

Rosemount 5600 non-contact process radar with parabolic antenna measures solid levels reliably and continuously, eliminating overflow and spillage.

## Waste Water, Chemical storage, Fuel Oil Tank and Offsite Level Measurement

Constantly monitor supplies for effective tank utilization without compromising safety or environmental compliance. Utilize existing tank connections where possible.



Rosemount Level Instrumentation

Rosemount DP level with Tuned-Systems™ capability provides a 30% improvement in performance and a 20% savings over traditional installations. Rosemount Radar provides top-down level measurement that is immune to changes in fluid density or vapor space. High and low level switches provide additional overflow and pump protection. All Rosemount level instrumentation is available in a wide variety of configurations and materials for handling corrosive liquids and vapors.

## Closed Cooling water, Make-up Water, Flue Gas Flow and Offsite Flow Measurements

Maximize energy savings through optimal cycling of water pumps over all plant load conditions. Accurately determine plant performance and efficiency. Ensure strict environmental compliance while reducing emissions.

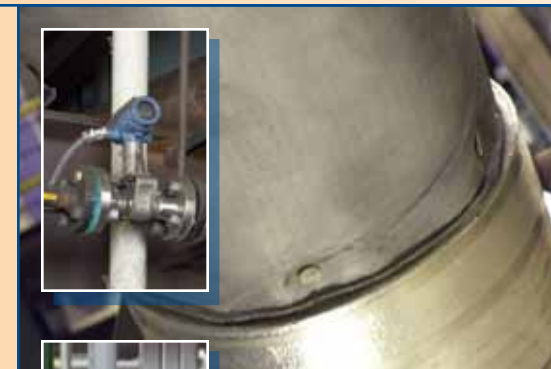

Rosemount Flow Instrumentation

Rosemount flow instrumentation is available in orifice, Annubar averaging pitot tube, magnetic flow and vortex flowmeters. These meters provide unmatched accuracy and best-in-class diagnostics. Rosemount flow instrumentation can meet a wide variety of applications, from the smallest to the largest line sizes in pipes, ducts, and stacks.

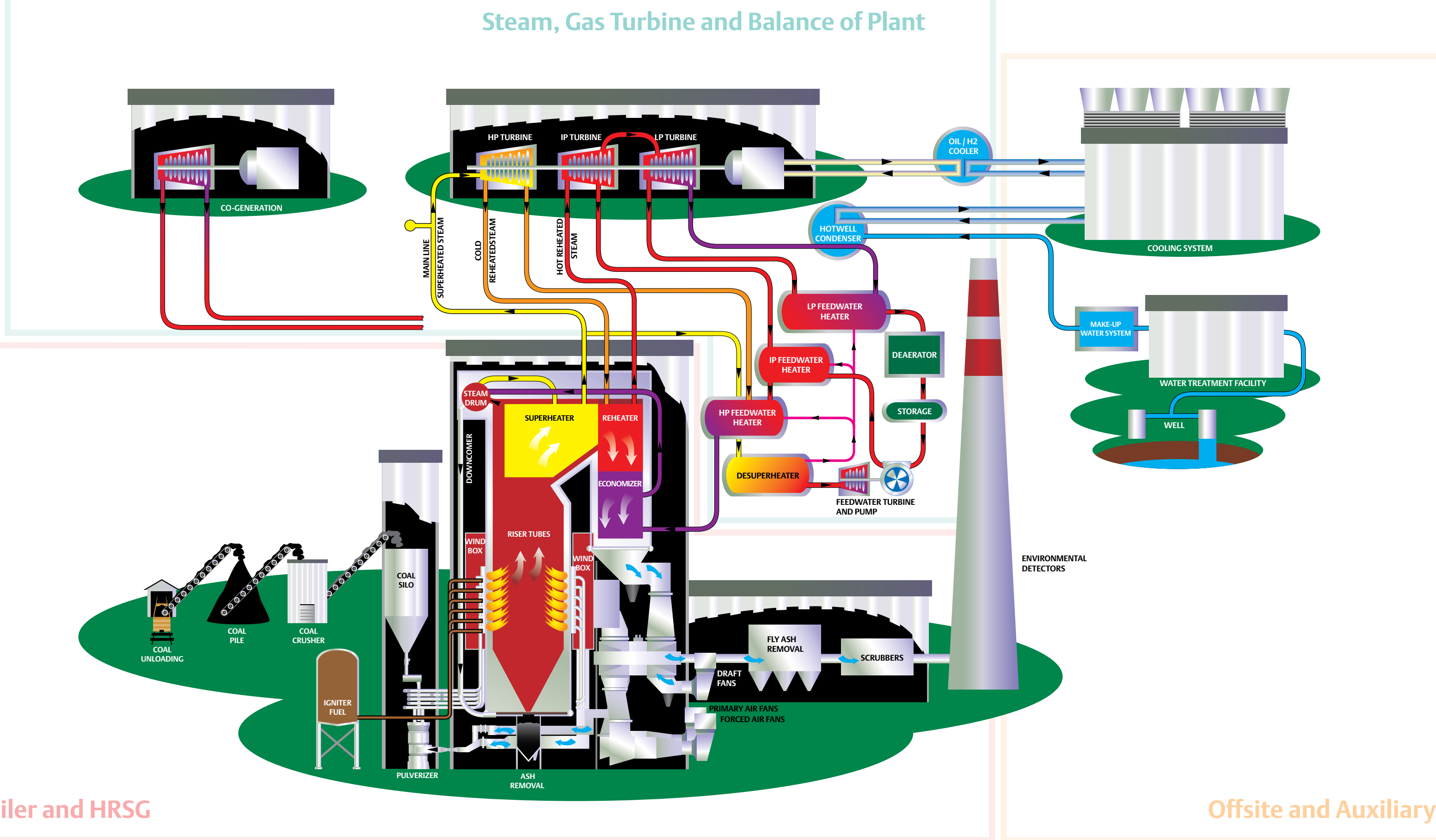

The Emerson logo is a trademark and service mark of Emerson Electric Co. Rosemount and the Rosemount logotype are registered trademarks of Rosemount Inc. PlantWeb is a registered trademark of the Emerson Process Management group of companies. All other marks are the property of their respective owners. ©2006 Rosemount Inc. All rights reserved.

**Emerson Process Management  
Rosemount Inc.**

8200 Market Boulevard  
Chanhassen, MN 55317 USA  
T (U.S.) 1-800-999-9307  
T (International) (952) 906 8888  
F (952) 949 7001  
[www.rosemount.com](http://www.rosemount.com)

**Emerson Process Management  
Shared Services, Ltd**

Heath Place  
Bognor Regis  
West Sussex PO22 9SH  
England  
Tel 44 (0)1243 863 121  
Fax 44 (0)1243 867 554

**Emerson Process Management  
Asia Pacific Private Limited**

1 Pandan Crescent  
Singapore 128461  
T (65) 6777 8211  
F (65) 6777 0947  
[AP.RMT-Specialist@emersonprocess.com](mailto:AP.RMT-Specialist@emersonprocess.com)