



## KTM SERIES EB526/EB529/EB525 BALL VALVES

DN15 - DN40

KTM full bore Class 600, 900 & 1500 fire-safe and anti-static, high pressure ball valve for the chemical and petroleum industries



### FEATURES

- Designed to ASME B16.34
- Two piece bolted body design complies with ASME B16.34 & ASME VIII.
- ISO 5211 top mounting flange.
- Face to Face to API 6D / ASME B16.10
- Fire safe tested and certified to API 607 6th Ed. by Lloyd's Register Asia.
- Flange connection to ASME B16.5 as standard.
- Carbon steel or stainless steel body as standard.
- Precision 316 stainless steel ball and UNS S31803 stem as standard.
- Blow-out proof shouldered stem.
- Anti-static tested.
- A secondary metal 'fire-safe' seat.
- Cantilevered block seat as standard.
- Spring energized stem assembly to compensate for wear and temperature changes.
- Gauged body gasket depth provides leak tight seal and gapless center flange joint.
- Lever with padlocking facility as standard.
- Vented ball equalizes body cavity pressure in open position and prevents possible seat damage.
- Manufactured under quality system ISO 9001 Cert. No. MEL929678/A and API 6D Q1 Cert. No. 6D-0243.
- All valves factory hydro / air tested.
- Documentation to EN 10204 Type 3.1 including Test Certification and Material Certification for pressure containing components.

### GENERAL APPLICATION

Ideally suited for use in the oil and gas production, refining and chemical applications. Body material and wetted trim components conform to NACE MR0175 - 2002.

Hazardous areas handling flammable fuels, gases or chemicals where 'fire-safe', or anti-static valves are mandatory or desirable.

### TECHNICAL DATA

Model/Sizes:	EB526/EB529/EB525 DN15 to DN40 (NPS½ to NPS1½)
Pressure rating:	EB526: Class 600 EB529: Class 900 EB525: Class 1500
Temperature:	Carbon PTFE seat: 225°C Devlon V seat: 190°C



# KTM SERIES EB526/EB529/EB525 BALL VALVES

DN15 - DN40

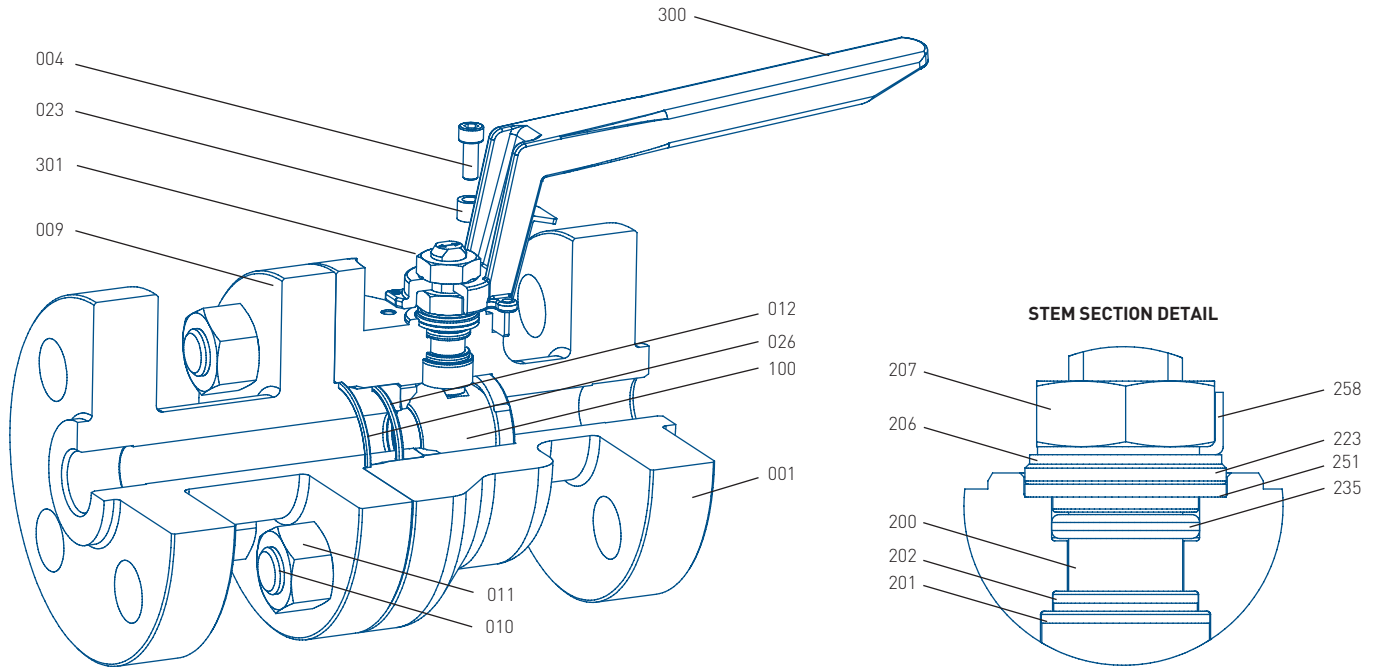

**NOTE:** DN 25 EB525 valve illustrated with body and wrench sectioned for clarity.

## PARTS LIST

No.	Description	Carbon steel	Carbon steel (Impact tested)	Stainless steel
001	Body	ASTM A105N	ASTM A350-LF2	ASTM A182-F316
004	Stop pin	UNS S31600	UNS S31600	UNS S31600
009	Body connector	ASTM A105N	ASTM A350-LF2	ASTM A182- F316
010	Body stud	ASTM A193 Gr B7	ASTM A320 Gr L7	ASTM A193 Gr B8M
011	Body nut	ASTM A194 Gr 2H	ASTM A194 Gr 4	ASTM A194 Gr 8M
012	Body seal	FKM-ED resistant O-ring	FKM-ED resistant O-ring	FKM-ED resistant O-ring
023	Stop pin spacer	UNS S31600	UNS S31600	UNS S31600
026	Auxiliary firesafe seal	Flexible graphite	Flexible graphite	Flexible graphite
100	Ball	UNS S31600	UNS S31600	UNS S31600
101	Seat (Code C - cantilevered)	Carbon reinforced PTFE	Carbon reinforced PTFE	Carbon reinforced PTFE
101	Seat (Code V - cantilevered)	Devlon V®	Devlon V®	Devlon V®
200	Stem	UNS S31803	UNS S31803	UNS S31803
201	Primary stem seal & anti-static seal ring	Carbon reinforced PTFE	Carbon reinforced PTFE	Carbon reinforced PTFE
202	Firesafe stem seal / anti-static ring	Flexible graphite	Flexible graphite	Flexible graphite
206	Stem spring	Inconel	Inconel	Inconel
207	Stem nut	UNS S31600	UNS S31600	UNS S31600
223	Stem seal follower	UNS S31600	UNS S31600	UNS S31600
235	Auxiliary stem seal	FKM-ED resistant O-ring	FKM-ED resistant O-ring	FKM-ED resistant O-ring
251	Weather seal	Comp. carbon fiber	Comp. carbon fiber	Comp. carbon fiber
258	Lock washer	UNS S31600	UNS S31600	UNS S31600
300	Wrench	UNS S31600	UNS S31600	UNS S31600
301	Wrench retainer	UNS S31600	UNS S31600	UNS S31600
532	Anti-static device (not shown)	UNS S31600 / Inconel	UNS S31600 / Inconel	UNS S31600 / Inconel

**NOTE:** Pressure containing materials conform with NACE MR0175-2002.

# KTM SERIES EB526/EB529/EB525 BALL VALVES

DN15 - DN40

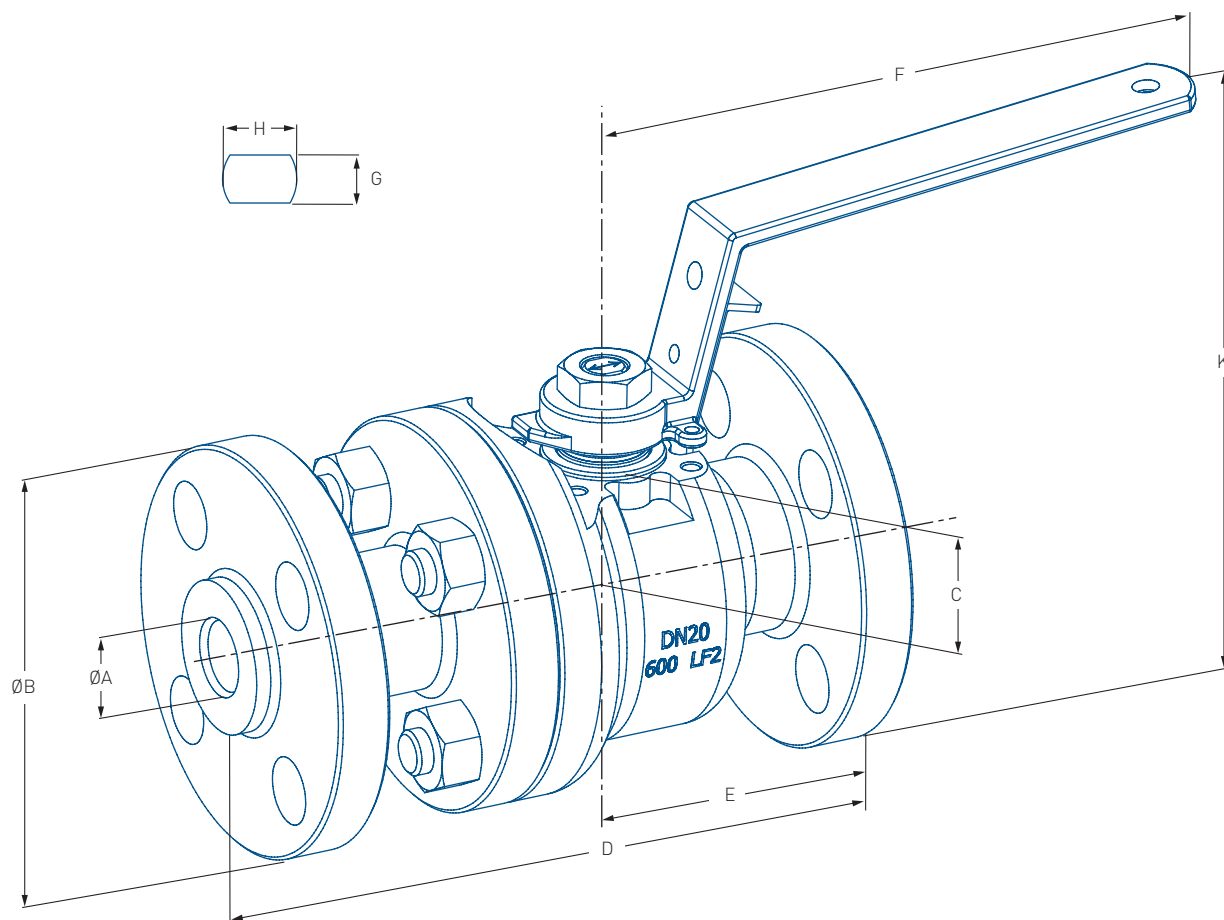

## DIMENSIONS (mm) DN 15 - 40 (FULL BORE)

Valve size		Bore ØA	ØB			D		E			Top plate data				Mass (kg)				
DN	NPS		Class		Class		Class			Stem conn. ØH X G	ISO Mtg	No. holes	Hole dia	PCD	Class		K <sub>v</sub> Class		
		600	1500	C	600	1500	600	1500	F						K	600		1500	900/
15	½	13	95	120	36.5	165	216	64	78.0	180	113	14.3 x 9.5	F05	4	M6	50	7	11	7.9
20	¾	19	115	130	36.5	191	229	72	83.5	180	113	14.3 x 9.5	F05	4	M6	50	9	13	26.2
25	1	25	125	150	48.0	216	254	77	90.0	210	138	14.3 x 9.5	F05	4	M6	50	13	21	45.3
40	1½	38	155	180	57.5	241	305	93	111.0	295	163	19.0 x 12.7	F07	4	M8	70	22	32	132

### NOTES:

F = The handle dimension when the valve is in the open position.

H = The diameter of the stem connection.

G = The dimension across the stem flats.

K<sub>v</sub> = The flow rate of water in m<sup>3</sup>/hr

C<sub>v</sub> = 1.155 K<sub>v</sub>.

Dimensions are nominal to ±1 mm.

# KTM SERIES EB526/EB529/EB525 BALL VALVES

## DN15 - DN40

PRESSURE/TEMPERATURE GRAPH

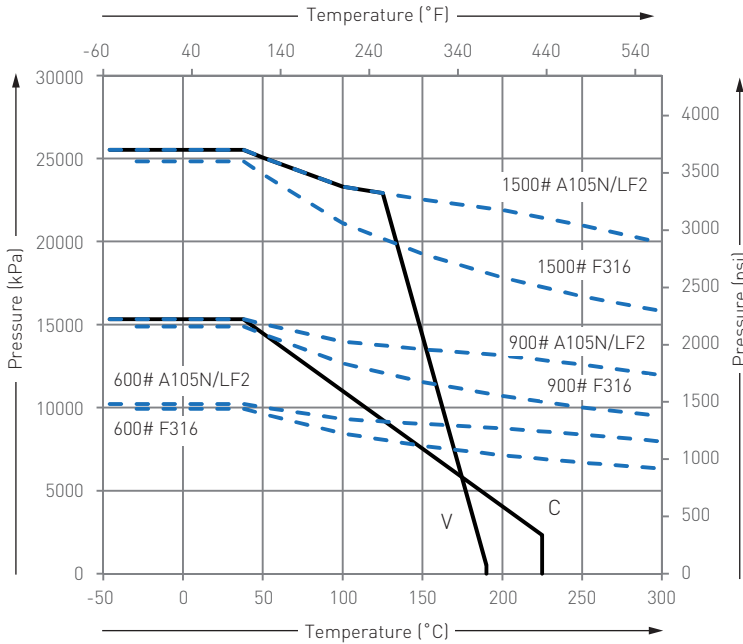

### PRESSURE/TEMPERATURE RATINGS

#### Class 600 (Figure EB526)

##### Seat code C - Carbon reinforced PTFE

A105N carbon steel: 10210 kPa /102.1 bar max at 38°C  
 LF2 carbon steel: 10210 kPa /102.1 bar max at 38°C  
 F316 S/S: 9930 kPa /99.3 bar max at 38°C

#### Class 900 (Figure EB529)

##### Seat code C - Carbon reinforced PTFE

A105N carbon steel: 15320 kPa /153.2 bar max at 38°C  
 LF2 carbon steel: 15320 kPa /153.2 bar max at 38°C  
 F316 S/S: 14890 kPa /148.9 bar max at 38°C

#### Class 1500 (Figure EB525)

##### Seat code V - Devlon V

A105N carbon steel: 25530 kPa /255.3 bar max at 38°C  
 LF2 carbon steel: 25530 kPa /255.3 bar max at 38°C  
 F316 S/S: 24820 kPa /248.2 bar max at 38°C

### NOTES

1. These pressure/temperature ratings displayed are for total valve assembly with the respective seat material fitted.
2. Seat pressure/temperature limitations displayed are in combination with FKM ED resistant O-ring seals. For other seat/sealing materials refer to Emerson.
3. A105N carbon steel valves have a minimum temperature limitation of minus 29°C.
4. LF2 carbon steel valves have a minimum temperature limitation of minus 46°C.

# KTM SERIES EB526/EB529/EB525 BALL VALVES

DN15 - DN40

## TYPICAL SPECIFYING SEQUENCE - CLASS 600, 900 AND CLASS 300

040	EB526	C	A	A	C	S	V	3	-	01
Valve size	Figure no.	Body material	End conn. (note 1)	End conn. (note 1)	Seat type	Trim material	Body seal	Certification code (note 2)	Valve variant	Standard option

Size range: DN 15 - 40 (full bore)

Figure no.: EB526 – Fire safe, anti-static, Class 600, full bore, floating ball design ball valve, wrench operated  
 EB529 – Fire safe, anti-static, Class 900, full bore, floating ball design ball valve, wrench operated  
 EB525 – Fire safe, anti-static, Class 1500, full bore, floating ball design ball valve, wrench operated

Figure no.	Trim code	Body material	End conn.	End conn.	Seat	Trim	Body O-ring seal
EB526	CAACSV	A105N carbon steel	Flg ASME	Flg ASME	Carbon R'PTFE	316 S/S	FKM ED resistant
EB526	LAACSV	LF2 carbon steel	Flg ASME	Flg ASME	Carbon R'PTFE	316 S/S	FKM ED resistant
EB526	SAACSV	UNS S31600	Flg ASME	Flg ASME	Carbon R'PTFE	316 S/S	FKM ED resistant
EB529	CAACSV	A105N carbon steel	Flg ASME	Flg ASME	Carbon R'PTFE	316 S/S	FKM ED resistant
EB529	LAACSV	LF2 carbon steel	Flg ASME	Flg ASME	Carbon R'PTFE	316 S/S	FKM ED resistant
EB529	SAACSV	UNS S31600	Flg ASME	Flg ASME	Carbon R'PTFE	316 S/S	FKM ED resistant
EB525	CAAVSV	A105N carbon steel	Flg ASME	Flg ASME	Devlon V	316 S/S	FKM ED resistant
EB525	LAAVSV	LF2 carbon steel	Flg ASME	Flg ASME	Devlon V	316 S/S	FKM ED resistant
EB525	SAAVSV	UNS S31600	Flg ASME	Flg ASME	Devlon V	316 S/S	FKM ED resistant

## NOTES

- For end connection details refer to Emerson.
- Certification code: Standard certification code 3 includes pressure test certification and material certification of the pressure containing components conforming to EN 10204 / ISO 10474 Type 3.1. For additional certification requirements, refer to Emerson.
- Valve variant: Standard valve is not offered with variants. Should a valve variant be required, refer to Emerson for variant listing and order code details.
- Standard options: Base valve is supplied with lockable wrench operator - Code 01. For other valve options, refer to Emerson for listing and order code details.  
 Where fitment of gearbox or actuator is required, the order requirement is to be specified as 'Complete With' followed by the details of the requirement - eg: Complete with Gearbox.

Neither Emerson, Emerson Automation Solutions, nor any of their affiliated entities assumes responsibility for the selection, use or maintenance of any product. Responsibility for proper selection, use, and maintenance of any product remains solely with the purchaser and end user.

KTM is a mark owned by one of the companies in the Emerson Automation Solutions business unit of Emerson Electric Co. Emerson Automation Solutions, Emerson and the Emerson logo are trademarks and service marks of Emerson Electric Co. All other marks are the property of their respective owners.

The contents of this publication are presented for informational purposes only, and while every effort has been made to ensure their accuracy, they are not to be construed as warranties or guarantees, express or implied, regarding the products or services described herein or their use or applicability. All sales are governed by our terms and conditions, which are available upon request. We reserve the right to modify or improve the designs or specifications of such products at any time without notice.

[Emerson.com/FinalControl](http://Emerson.com/FinalControl)