



## KEYSTONE SERIES 36 AND 37 K-LOK HIGH PERFORMANCE BUTTERFLY VALVES

K-LOK Series 36 - ASME 150  
 K-LOK Series 37 - ASME 300



### FEATURES AND BENEFITS

- K-LOK polymer and elastomer seats provide bi-directional, drop-tight shut-off in vacuum as well as at full rated differential pressure. Its unique design does not rely on pressure to assist sealing therefore seals at high and low pressures, as well as dirty services. A variety of materials allows optimum seat life in all applications.
- Blow-out resistant shaft is standard on all valves for increased safety.
- Unique packing design allows for use in pressure as well as vacuum without modification or special assembly.
- Disc taper pins are tangentially positioned half in disc and half in shaft, placing them in compression rather than shear, which eliminates potential for failure.
- Rocker-shaped gland bridge compensates for uneven adjustment of gland nuts reducing packing leaks.
- Integrally cast disc position stop perfectly locates the disc in seat, achieving maximum seat and seal life.
- Extended neck allows for 50 mm (2") of pipeline insulation.
- Integrally cast mounting pad provides direct mounting of actuators eliminating the need for costly brackets and couplings.
- Flattened body bore at shaft journal ports positions shaft bearings near disc, providing maximum shaft support resulting in reduced wear and longer life.

### GENERAL APPLICATIONS

- Modulating service
- Airport refueling
- Hydrocarbon processing
- Chemical/petrochemical processing
- Purified gas
- Steam and vacuum services
- Power and utilities
- Refrigeration
- HVAC
- Alumina refining

### TECHNICAL DATA

Size range: DN 50 - 600 (NPS 2 - 24)  
 See note below for DN 750 - 900 (NPS 30-36)

Vacuum rating: 1.016 x 10<sup>-3</sup> mm (4 x 10<sup>-5</sup> in) Hg

Body style: Wafer, lug and double flanged

Pressure rating: Series 36 - ASME 150  
 Series 37 - ASME 300

Temperature rating: -40°C to 538°C  
 (-40°F to 1000°F)

Metal seated, fire-safe and DN 750-900 (NPS 30-36) valves are available. For more information on these items see Figures 360/362 data sheet (VCTDS-00032).

Lug and double flange bodies are full rated for bidirectional dead end service.

# KEYSTONE SERIES 36 AND 37 K-LOK HIGH PERFORMANCE BUTTERFLY VALVES

## PRINCIPLES OF OPERATION

### Double offset disc/shaft

K-LOK's unique two-piece shaft and double-offset disc/shaft design allows for high cycling and creates a lower disc profile with increased capacity and a rangeability of 33:1. In addition to increasing the flow area across the disc, this design minimizes wear points between seat and disc. The first offset is achieved by locating the shafts downstream of the center-line of the seat. This allows for a totally unobstructed 360° sealing surface. The second offset locates the shafts off-center of the vertical axis of the seat. The combination of these two offsets creates a camming effect as the disc swings into and out of the seat. The disc lifts quickly out of the seat in the first few degrees of travel and does not contact the seat again until it is nearly closed. There are no wear points between the seat and disc, while operating torques are reduced and seat life is extended.

DOUBLE OFFSET

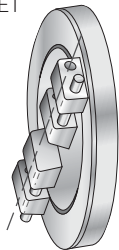

FIRST OFFSET

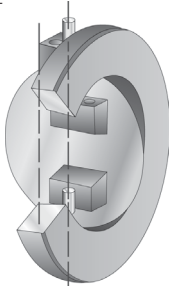

SECOND OFFSET

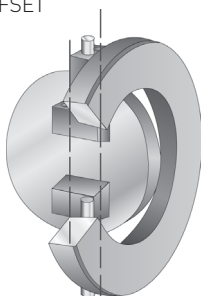

### Adjustable shaft packaging (polymer seated valves)

The K-LOK's unique shaft packaging is composed of 3 rings of braided PTFE rope between one PTFE V-ring at the top and bottom. The packing operates on an interference fit with the body and therefore will seal in pressure and vacuum. Many other manufacturers' designs will require special packing for vacuum services. This packing is easily field adjustable without the need to remove actuation due to its unique inverted packing adjustment bolts. Another important feature is the use of a rocker shaped packing gland bridge that compensates for uneven tightening of the packing gland bolts eliminating packing leaks due to uneven packing compression.

### Blow-out resistant shaft (BOR)

The Keystone K-LOK high performance butterfly valve contains a blow-out resistant shaft as a standard. This is achieved by machining a groove in the shaft that allows a snap ring to lock into the shaft groove. The packing gland follower is provided with an undercut on its lower surface which encapsulates the locked in snap ring. This design provides positive retention of the shaft in the unlikely event of a shaft breakage.

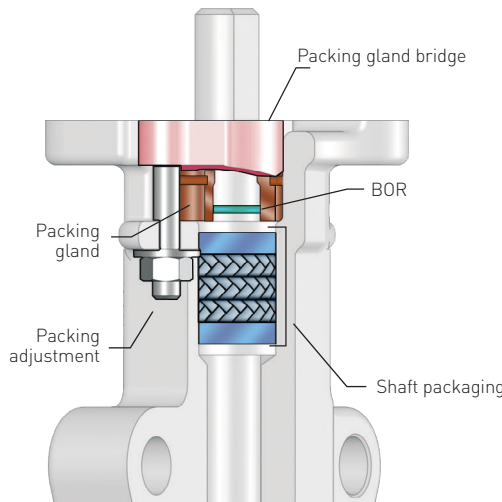

### Two-piece shaft vs. one-piece shaft

K-LOK's disc geometry maximizes flow capacity by increasing the available flow area through the valve. This increase in disc efficiency results in a higher valve  $C_v$ .

Competitor one-piece shaft

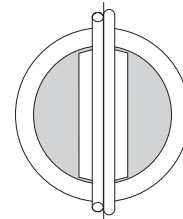

K-LOK two-piece shaft

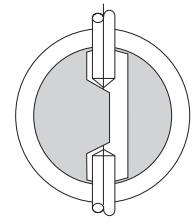

Aspect ratio = open area ÷ disc area

### Standards and specifications applicable for K-LOK®

ASME	B16.34	Steel valves
	B31.3	Chemical plant and petroleum refinery piping
	B16.5	Steel pipe flanges and flange fittings
MSS	SP-6	Standard finishes for pipe flanges
	SP-25	Standard marking systems for valves
	SP-55	Quality standard for steel casting
	SP-61	Pressure testing of steel valves
API	609	Butterfly valves (most models)
	607	Fire-test for soft seated quarter-turn valves
	598	Valve inspection and test, upon request
NSF/ANSI Standard 61		Potable water, upon request
PED/CE		European directive, upon request

# KEYSTONE SERIES 36 AND 37 K-LOK HIGH PERFORMANCE BUTTERFLY VALVES

## SEAT DESIGN

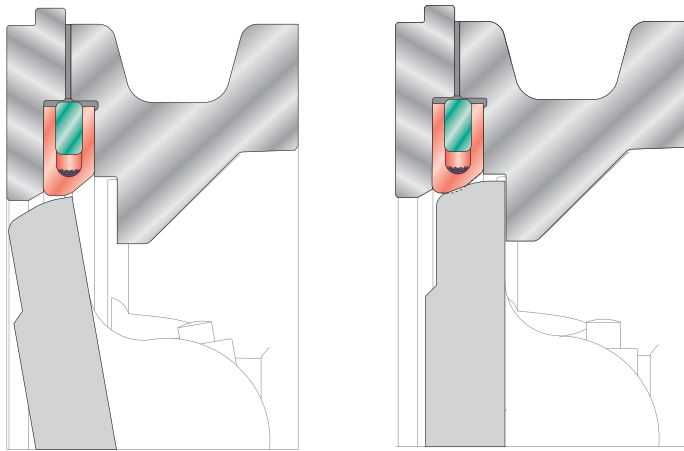

## SEAT DESIGN

The K-LOK seat is a true interference seat design and unlike most other manufactures does not rely on line pressure to assist in sealing. All seats seal drop-tight bi-directionally at low and high pressure as well as vacuum. Given the interference seat design the K-LOK will also operate in dirty services where most pressure assist valves fail.

Polymer (PTFE, RTFE and UHMWPE) seats incorporate a unique design consisting of a stainless steel braided wire winding, enclosed in a U-shape envelope to provide seating energy and memory. This wire winding allows axial flexibility in both directions of flow. The winding also allows radial flexibility when the disc is not fully closed, reducing seat/disc interference, seat wear and shaft torque. When the disc closes, it provides circumferential stiffness and assures the required disc/seat seals tight in both vacuum and pressure.

Elastomer seats are molded around a stack of V-shaped steel rings that provide the same stability, support and flexure as the wire windings in polymer seats.

## SEAT MATERIALS

Seat	Material	Typical applications
1. RTFE	Reinforced polytetrafluoroethylene	HVAC, steam, chlorine, ammonia, nitrogen, water, gasoline, vacuum
2. PTFE	Polytetrafluoroethylene	Pharmaceuticals, air, potable water, dyes, white mediums
3. UHMWPE	Ultra high molecular weight polyethylene	Abrasives, suspended solids, scaling mediums
<b>For seats 1 thru 3</b>		
Wire wrap	Stainless steel braided wire	
Seat backing ring	Phenolic	General purpose services
	Stainless steel	Steam, ammonia, elevated temperature services

Seat	Material	Typical applications
4. EPDM	-	Water based mediums, slurry applications, abrasives
5. NBR	-	Oil based mediums, slurry applications, abrasives
6. Fluoroelastomer (FKM)	-	Elevated temperatures, slurry applications, abrasives
<b>For seats 4 thru 6</b>		
Metal insert	Carbon steel	

## SEAT REPLACEMENT

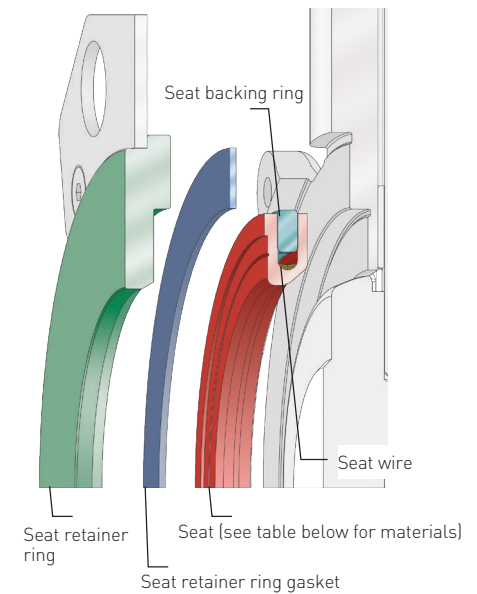

## SEAT REPLACEMENT

All seats for the Keystone K-LOK are easily field replaceable. Simply remove seat retainer ring, rotate disc to fully closed position and replace seat assembly and gasket. Dis-assembly of the disc and shaft is not required. Seat retaining ring gaskets are not used with elastomer seats.

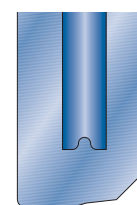
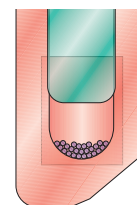

# KEYSTONE SERIES 36 AND 37 K-LOK HIGH PERFORMANCE BUTTERFLY VALVES

## SEAT TIGHTNESS

All polymer seated valves are factory tested for bi-directional drop tight shut-off at 10% above the rated pressure. This exceeds the ANSI FCI 70-2 standard which establishes a service of six leakage classes for control valves as per below:

### ANSI/FCI 70-2 CONTROL VALVE SEAT LEAKAGE, TOLERANCES, AND TEST SPECIFICATIONS

ANSI B16.104-1976	Maximum leakage			Test medium	Pressure and temperature
Class VI	Nominal port diameter DN (NPS)	Bubbles per minute <sup>[a]</sup>	ml. per minute	Air or nitrogen	Service ΔP or 3.4 bar differential, whichever is lower, at 10°C - 52°C (50°F - 125°F)
	50 (2)	3	0.45		
	65 (2½)	4	0.60		
	80 (3)	6	0.90		
	100 (4)	11	1.70		
	150 (6)	27	4.00		
	200 (8)	45	6.75		
Class V	5 x 10 <sup>-12</sup> m <sup>3</sup> /sec/bar differential/mm port dia.			Water	Service ΔP at 10°C - 52°C (50°F - 125°F)
Class IV	0.01% valve capacity at full travel			Air or water	Service ΔP or 3.4 bar differential, whichever is lower, at 10°C - 52°C (50°F - 125°F)

### NOTES

1. K-LOK polymer and elastomer seats meet or exceeds ANSI Class VI shut-off.
2. K-LOK metal seats and fire-safe seats (post fire exposure) meet or exceeds ANSI Class IV shut-off.
3. Using the ANSI/FCI specified calibrated measuring device.

Reference ANSI/FCI 70-2 for further information.

### ABRASION RESISTANT TRIMS (UP TO 93°C/200°F)

Body	Disc	Shaft	Seat/backing ring	Gasket	Packing	Bearing
Carbon steel	316 SS/ENP	17-4PH SS	UHMWPE/Phenolic	Non asbestos fiber	PTFE	RTFE/ Composite
316 SS	316 SS/ENP	17-4PH SS	UHMWPE/Phenolic	Non asbestos fiber	PTFE	RTFE/ Composite

### GENERAL PURPOSE TRIMS (UP TO 260°C/500°F)

Body	Disc	Shaft	Seat/backing ring	Gasket	Packing	Bearing
Carbon steel	316 SS	17-4PH SS	RTFE/SS	Graphite	PTFE	316/BRZ/PTFE
316 SS	316 SS	17-4PH SS	RTFE/SS	Graphite	PTFE	316/BRZ/PTFE

### STEAM TRIMS

Body	Disc	Shaft	Seat/backing ring	Gasket	Packing	Bearing
Carbon steel	316 SS/ENP	17-4PH SS	RTFE/SS	Graphite	PTFE	316/BRZ/PTFE
316 SS	316 SS/ENP	17-4PH SS	RTFE/SS	Graphite	PTFE	316/BRZ/PTFE

### CORROSION RESISTANT TRIMS

Body	Disc	Shaft	Seat/backing ring	Gasket	Packing	Bearing
316 SS	316 SS	316 SS Cond. B	RTFE/Phenolic	Non asbestos fiber	PTFE	RTFE/ Composite
316 SS	316 SS	NITRONIC 50®	RTFE/Phenolic	Non asbestos fiber	PTFE	RTFE/ Composite
2205 Duplex	2205 Duplex	2205 Duplex	RTFE/Phenolic	Graphite	PTFE	RTFE/ Composite
2507 Super Duplex	2507 Super Duplex	2507 Super Duplex	RTFE/Phenolic	Graphite	PTFE	RTFE/ Composite

### NOTE

other trims are available, please contact your sales representative

### SPECIAL SERVICE VALVES AVAILABLE

- Oxygen cleaned valves
- NSF-61 certified valves
- Chlorine cleaned valves
- Seawater valves
- Alloy trimmed valves
- PED/CE certified valves

Please contact your local sales representative for other requests.

# KEYSTONE SERIES 36 AND 37 K-LOK HIGH PERFORMANCE BUTTERFLY VALVES

## MATERIALS OF CONSTRUCTION

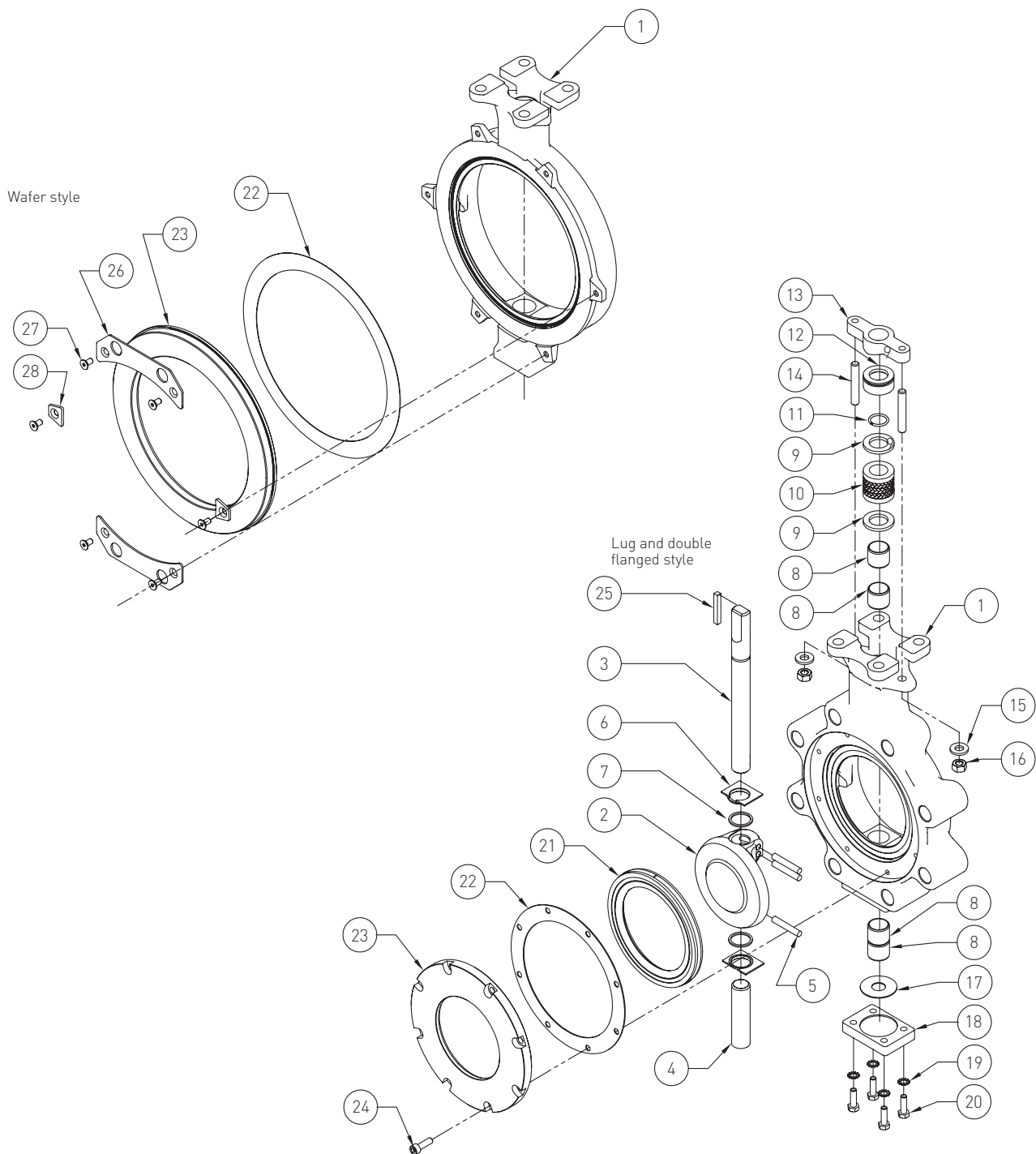

# KEYSTONE SERIES 36 AND 37 K-LOK HIGH PERFORMANCE BUTTERFLY VALVES

## STANDARD MATERIALS OF CONSTRUCTION

Pos	Description	Material	Material standard
1	Body	Carbon steel	ASTM A216-WCB
		Stainless steel	ASTM A351-CF8M
2	Disc	316 SS	ASTM A351-CF8M
		316 SS/ENP	ASTM A351-CF8M / Electroless nickel plated
3	Upper shaft	316B SS	ASTM A276-316 Condition B
		17-4PH SS	ASTM A564- Condition H1075 or H1100
		Nitronic 50	ASTM A276-XM19
4	Lower shaft	316B SS	ASTM A276-316 Condition B
		17-4PH SS	ASTM A564- Condition H1075 or H1100
		Nitronic 50	ASTM A276-XM19
5	Taper pin	316B SS	ASTM A276-316 Condition B
		17-4PH SS	ASTM A564- Condition H1075 or H1100
		Nitronic 50	ASTM A276-XM19
6	Spacer	316 SS	
7	Thrust washer	316 SS / BRZ / PTFE	
8	Bearing	316 SS / BRZ / PTFE	
		RTFE / Composite	
		316SS / Nitrited	
9	Anti-extrusion ring	316 SS	
10	Stem packing	PTFE , Graphite	
11	Ring, stem retention	316 SS	
12	Gland	316 SS	
13	Gland bridge	17-4PH SS	
14	Stud	Stainless steel 18.8	
15	Washer, split lock	Stainless steel 18.8	
16	Hex nut	Stainless steel 18.8	
17	Bottom cover gasket	Graphite	
		Non-asbestos fiber	
18	Bottom cover	Carbon steel	ASTM A216-WCB
		Stainless steel	ASTM A351-CF8M
19	Washer, ext. Tooth lock	Stainless steel 18.8	
20	Screw, hex hd cap	Stainless steel 18.8	
21	Seat assembly		
21.1	Seat	Polymer	PTFE , RTFE, UHMWPE
		Elastomer	NBR, EPDM, FKM
21.2	Wire structure	Stainless steel	
21.3	Seat backing ring	Stainless steel	
		Phenolic	
22	Gasket seat retaining ring	Graphite	Not used with Elastomer seats
		Non-asbestos fiber	
23	Seat retaining ring	Carbon steel	ASTM A216-WCB
		Stainless steel	ASTM A351-CF8M
24	Screw, socket hd cap	Stainless steel	
25	Key	Carbon steel	
26	Retainer plate	Stainless steel	
		Carbon steel / zinc plated	
27	Retainer plate/clip screw	Stainless steel 18.8	
28	Clip	Stainless steel	
		Carbon steel / zinc plated	

All fasteners are 18-8 SS

# KEYSTONE SERIES 36 AND 37 K-LOK HIGH PERFORMANCE BUTTERFLY VALVES

## METRIC DATA

### DIMENSIONS - WAFER STYLE

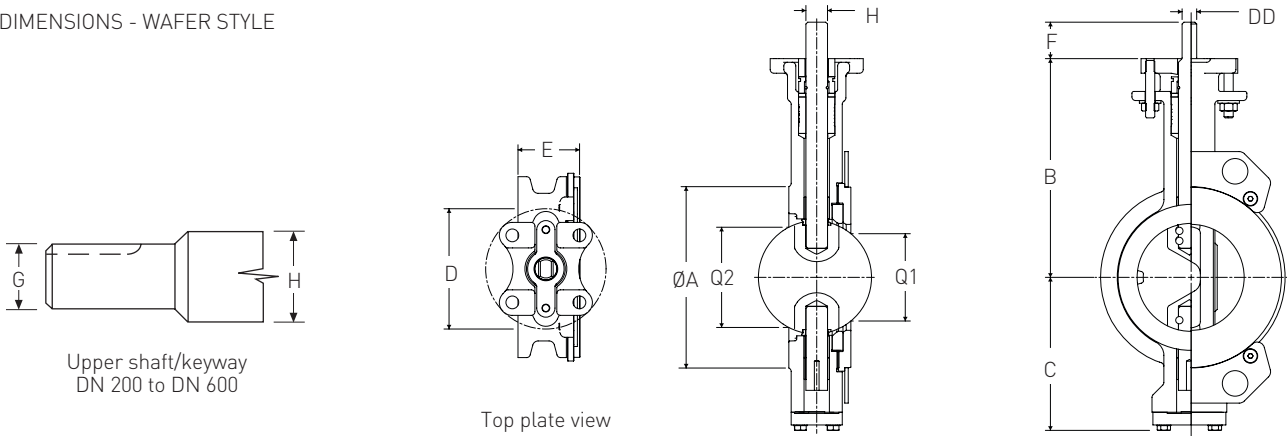

### SERIES 36, ASME CLASS 150, WAFER STYLE, DIMENSIONS (mm)

Size DN	A	B	C	D	E	F	G	H	Q1	Q2	Top plate drilling				Weight (kg)	Mounting code	
											DD or keyway		PCD	No. holes			Hole dia.
											(mm)	(inch)					
50	110	152	102	105	60	32	N/A	14.29	35	48	9.53	3/8	83	4	11	5	BAB
65	105	152	114	105	48	32	N/A	14.29	56	57	9.53	3/8	83	4	11	4	BAB
80	127	168	126	105	48	32	N/A	15.88	54	67	11.11	7/16	83	4	11	5	BAC
100	157	191	133	105	54	32	N/A	19.05	81	92	12.70	1/2	83	4	11	8	BAD
125	186	192	146	105	57	32	N/A	19.05	111	121	12.70	1/2	83	4	11	10	BAD
150	216	222	179	154	57	32	19.05	22.23	133	141	12.70	1/2	127	4	14	14	CAD
150*	216	222	179	154	57	32	N/A	22.23	133	141	15.88	3/8	127	4	14	14	CAE
200	270	257	211	154	64	51	N/A	28.58	178	187	6.35 x 6.35 x 41	1/4 x 1/4 x 1 1/8	127	4	14	21	CAF
250	324	289	244	154	71	51	28.58	34.93	232	237	6.35 x 6.35 x 41	1/4 x 1/4 x 1 1/8	127	4	14	34	CAF
250*	324	289	244	154	71	76	N/A	34.93	232	237	7.94 x 7.94 x 67	5/16 x 5/16 x 2 5/8	127	4	14	34	CAG
300	381	330	287	208	81	76	34.93	38.10	278	284	7.94 x 7.94 x 67	5/16 x 5/16 x 2 5/8	165	4	21	53	DAG
350	413	337	326	208	92	76	N/A	41.28	298	311	9.53 x 9.53 x 67	3/8 x 3/8 x 2 5/8	165	4	21	60	DAH
400	470	368	323	208	102	76	41.28	44.45	340	359	9.53 x 9.53 x 67	3/8 x 3/8 x 2 5/8	165	4	21	84	DAH
450	533	406	349	208	114	103	N/A	47.63	395	405	12.70 x 9.53 x 105	1/2 x 3/8 x 4 1/8	165	4	21	131	DAJ
500	584	443	386	209	127	110	N/A	57.15	440	449	12.70 x 9.53 x 102	1/2 x 3/8 x 4	165	4	21	171	DAK
600	692	500	446	209	154	108	57.15	63.50	524	535	12.70 x 9.53 x 102	1/2 x 3/8 x 4	165	4	21	269	DAK

\* E.N.P. discs require larger upper shaft connection diameters on DN 150 and DN 250 valve sizes for UHMWPE seat trims.

N/A = not applicable

### SERIES 37, ASME CLASS 300, WAFER STYLE, DIMENSIONS (mm)

Size DN	A	B	C	D	E	F	G	H	Q1	Q2	Top plate drilling			Tapped lug data			Weight (kg)	Mounting code		
											DD or keyway		PCD	No. holes	Holes dia.	No. holes			PCD	Tap
											(mm)	(inch)								
50	110	152	102	105	60	32	N/A	14.29	35	48	9.53	3/8	83	4	11	-	-	-	5	BAB
65	105	152	114	105	48	32	N/A	14.29	56	57	9.53	3/8	83	4	11	-	-	-	4	BAB
80	127	168	124	105	48	32	N/A	15.88	52	67	11.11	7/16	83	4	11	-	-	-	5	BAC
100	157	191	133	105	54	32	N/A	19.05	81	92	12.70	1/2	83	4	11	-	-	-	8	BAD
125	186	192	146	105	59	32	N/A	19.05	110	121	12.70	1/2	83	4	11	-	-	-	10	BAD
150	216	222	179	154	59	51	N/A	22.23	133	141	15.88	5/8	127	4	14	-	-	-	14	CAE
200	270	257	211	154	73	51	N/A	28.58	171	187	6.35 x 6.35 x 41	1/4 x 1/4 x 1 1/8	127	4	14	-	-	-	25	CAF
250	324	289	244	154	83	76	N/A	34.93	224	237	7.94 x 7.94 x 67	5/16 x 5/16 x 2 5/8	127	4	14	4	387	1-8UNC	42	CAG
300	381	330	287	208	92	76	34.9	38.10	270	284	7.94 x 7.94 x 67	5/16 x 5/16 x 2 5/8	165	4	21	-	-	-	58	DAG
350	413	365	321	208	117	108	N/A	47.63	300	303	12.70 x 9.53 x 105	1/2 x 3/8 x 4 1/8	165	4	21	4	514	1 1/8-8UN	92	DAJ
400	470	408	352	208	133	105	N/A	57.15	344	348	12.70 x 9.53 x 102	1/2 x 3/8 x 4	165	4	21	4	572	1 1/4-8UN	122	DAK
450	533	432	382	208	149	107	N/A	63.50	392	394	15.88 x 15.88 x 102	5/8 x 3/8 x 4	165	4	21	4	629	1 1/4-8UN	169	DBA
500	584	513	415	191	159	165	N/A	69.85	438	441	15.88 x 15.88 x 162	3/8 x 3/8 x 6 3/8	203	4	21	4	686	1 1/4-8UN	219	LAX
600	692	594	485	241	181	173	N/A	88.90	525	529	22.23 x 22.23 x 144	7/8 x 7/8 x 5 11/16	248	4	27	4	813	1 1/2-8UN	363	MAY

N/A = not applicable

# KEYSTONE SERIES 36 AND 37 K-LOK HIGH PERFORMANCE BUTTERFLY VALVES

## METRIC DATA

### DIMENSIONS - LUG STYLE

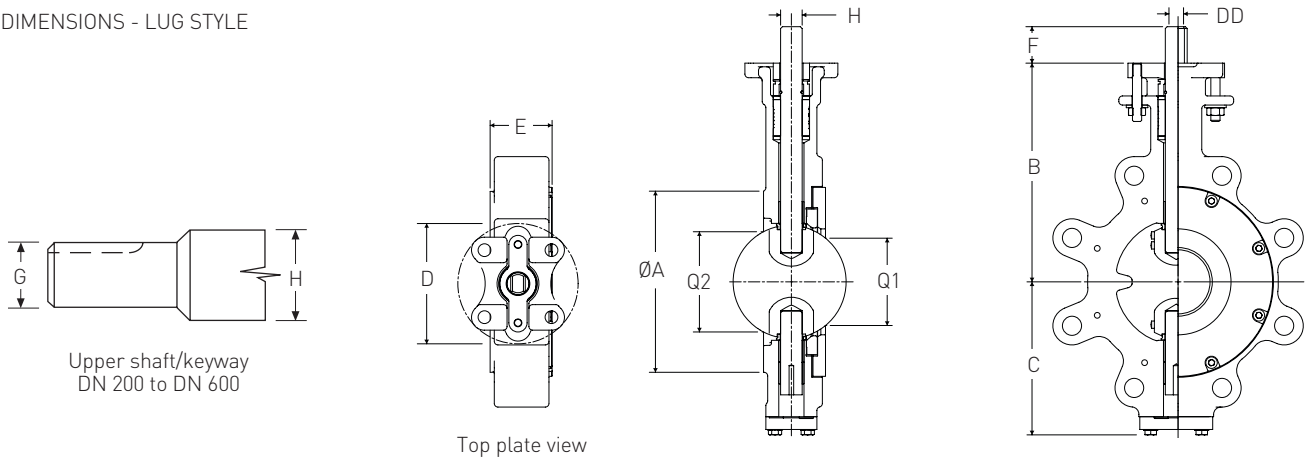

Upper shaft/keyway  
DN 200 to DN 600

Top plate view

### SERIES 36, ASME CLASS 150, LUG STYLE, DIMENSIONS (mm)

Size DN	A	B	C	D	E	F	G	H	Q1	Q2	Top plate drilling			Tapped lug data			Weight (kg)	Mount- ing code		
											DD or keyway		PCD	No. holes	Holes dia.	No. holes			PCD	Tap
(mm)	(inch)	(mm)	(inch)	(mm)	(inch)	(mm)	(inch)	(mm)	(inch)	(mm)	(inch)	(mm)					(inch)			
50	113	152	102	10	60	32	N/A	14.29	35	48	9.53	3/8	83	4	11	4	121	5/8-11UNC	5	BAB
65	121	152	110	10	48	32	N/A	14.29	56	57	9.53	3/8	83	4	11	4	140	5/8-11UNC	5	BAB
80	134	168	126	10	48	32	N/A	15.88	54	67	11.11	7/16	83	4	11	4	152	5/8-11UNC	7	BAC
100	164	191	133	10	54	32	N/A	19.05	81	92	12.70	1/2	83	4	11	8	191	5/8-11UNC	10	BAD
125	193	192	146	10	57	32	N/A	19.05	111	121	12.70	1/2	83	4	11	8	216	3/4-10UNC	14	BAD
150	225	222	149	154	57	32	19.05	22.23	133	141	12.70	1/2	127	4	14	8	241	3/4-10UNC	18	CAD
150*	225	222	149	154	57	32	N/A	22.23	133	141	15.88	5/8	127	4	14	8	241	3/4-10UNC	18	CAE
200	270	257	211	154	64	51	N/A	28.58	178	187	6.35 x 6.35 x 41	1/4 x 1/4 x 1 3/8	127	4	14	8	298	3/4-10UNC	27	CAF
250	324	289	244	154	71	51	28.58	34.93	232	237	6.35 x 6.35 x 41	1/4 x 1/4 x 1 3/8	127	4	14	12	362	7/8-9UNC	40	CAF
250*	324	289	244	154	71	76	N/A	34.93	232	237	7.94 x 7.94 x 67	5/16 x 5/16 x 2 5/8	127	4	14	12	362	7/8-9UNC	40	CAG
300	381	330	269	208	81	76	34.93	38.10	278	284	7.94 x 7.94 x 67	5/16 x 5/16 x 2 5/8	165	4	21	12	432	7/8-9UNC	67	DAG
350	413	337	301	208	92	76	N/A	41.28	298	311	9.53 x 9.53 x 67	3/8 x 3/8 x 2 5/8	165	4	21	12	476	1-8UNC	83	DAH
400	470	368	330	208	102	76	41.28	44.45	340	359	9.53 x 9.53 x 67	3/8 x 3/8 x 2 5/8	165	4	21	16	540	1-8UNC	97	DAH
450	533	406	349	208	114	103	N/A	47.63	395	405	12.70 x 9.53 x 105	1/2 x 3/8 x 4 1/8	165	4	21	16	578	1 1/8-8UNC	159	DAJ
500	584	443	386	209	127	110	N/A	57.15	440	449	12.70 x 9.53 x 102	1/2 x 3/8 x 4	165	4	21	20	635	1 1/8-8UNC	208	DAK
600	692	500	446	209	154	108	57.15	63.50	524	535	12.70 x 9.53 x 102	1/2 x 3/8 x 4	165	4	21	20	749	1 1/4-8UNC	319	DAK

\* E.N.P. discs require larger upper shaft connection diameters on DN 150 and DN 250 valve sizes for UHMWPE seat trims.

N/A = not applicable

### SERIES 37, ASME CLASS 300, LUG STYLE, DIMENSIONS (mm)

Size DN	A	B	C	D	E	F	G	H	Q1	Q2	Top plate drilling			Tapped lug data			Weight (kg)	Mount- ing code		
											DD or keyway		PCD	No. holes	Holes dia.	No. holes			PCD	Tap
(mm)	(mm)	(inch)	(mm)	(inch)	(mm)	(inch)	(mm)	(inch)	(mm)	(inch)	(mm)	(inch)					(mm)	(inch)		
50	113	152	101	105	60	32	N/A	14.29	35	48	9.53	3/8	83	4	11	8	127	5/8-11UNC	6	BAB
65	122	152	110	105	48	32	N/A	14.29	56	57	9.53	3/8	83	4	11	8	149	3/4-10UNC	7	BAB
80	135	168	118	105	48	32	N/A	15.88	52	67	11.11	7/16	83	4	11	8	168	3/4-10UNC	8	BAC
100	165	191	133	105	54	32	N/A	19.05	81	92	12.70	1/2	83	4	11	8	200	3/4-10UNC	11	BAD
125	194	192	146	105	59	32	N/A	19.05	110	121	12.70	1/2	83	4	11	8	235	3/4-10UNC	15	BAD
150	216	222	174	154	59	51	N/A	22.23	133	141	15.88	5/8	127	4	14	12	270	3/4-10UNC	20	CAE
200	270	257	211	154	73	51	N/A	28.58	171	187	6.35 x 6.35 x 41	1/4 x 1/4 x 1 3/8	127	4	14	12	330	7/8-9UNC	36	CAF
250	324	289	244	154	83	76	N/A	34.93	224	237	7.94 x 7.94 x 67	5/16 x 5/16 x 2 5/8	127	4	14	16	387	1-8UNC	54	CAG
300	381	330	282	208	92	76	34.93	38.10	270	284	7.94 x 7.94 x 67	5/16 x 5/16 x 2 5/8	165	4	21	16	451	1 1/8-8UNC	81	DAG
350	413	365	321	208	117	108	N/A	47.63	300	303	12.70 x 9.53 x 105	1/2 x 3/8 x 4 1/8	165	4	21	20	514	1 1/8-8UNC	133	DAJ
400	470	408	352	208	133	105	N/A	57.15	344	348	12.70 x 9.53 x 102	1/2 x 3/8 x 4	165	4	21	20	572	1 1/4-8UNC	177	DAK
450	533	432	382	208	149	107	N/A	63.50	392	394	15.88 x 15.88 x 102	5/8 x 5/8 x 4	165	4	21	24	629	1 1/4-8UNC	238	DBA
500	584	513	415	191	159	165	N/A	69.85	438	441	15.88 x 15.88 x 162	5/8 x 5/8 x 6 3/8	203	4	21	24	686	1 1/4-8UNC	298	LAX
600	692	594	485	241	181	173	N/A	88.90	525	529	22.23 x 22.23 x 144	7/8 x 7/8 x 5 1/16	248	4	27	24	813	1 1/2-8UNC	488	MAY

N/A = not applicable



# KEYSTONE SERIES 36 AND 37 K-LOK HIGH PERFORMANCE BUTTERFLY VALVES

## METRIC DATA

### DIMENSIONS - DOUBLE FLANGE STYLE

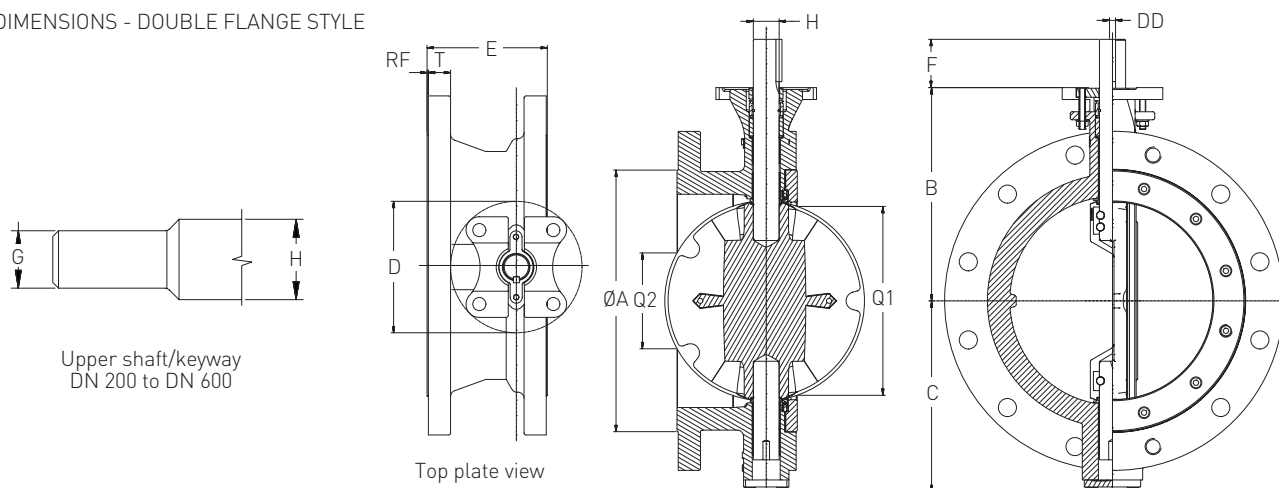

Upper shaft/keyway  
DN 200 to DN 600

Top plate view

### SERIES 36F, ASME CLASS 150, DOUBLE FLANGED STYLE, DIMENSIONS (mm)

Size DN	A	B	C	D	E	F	G	H	Q1	Q2	T	RF
80	127	168	126	105	114	32	N/A	15.88	54	N/A	19.1	2
100	157	191	133	105	127	32	N/A	19.05	82	N/A	24.0	2
150	216	222	161	154	140	32	19.05	22.23	133	N/A	25.5	2
150*	216	222	161	154	140	32	N/A	22.23	133	N/A	25.5	2
200	270	257	211	154	152	51	N/A	28.58	179	N/A	28.5	2
250	324	289	244	154	165	51	28.58	34.93	232	79	30.0	2
250*	324	289	244	154	165	76	N/A	34.93	232	79	30.0	2
300	381	330	269	208	178	76	34.93	38.10	277	123	31.5	2
350	413	337	301	208	190	76	N/A	41.28	303	152	35.0	2
400	470	368	330	208	216	76	41.28	44.45	348	159	36.5	2
450	533	406	349	208	222	103	N/A	47.63	394	271	39.5	2
500	584	443	386	209	229	110	N/A	57.15	440	333	43.0	2
600	692	500	446	209	267	108	57.15	63.50	528	399	47.5	2

### SERIES 36F, ASME, CLASS 150, DOUBLE FLANGED STYLE, DIMENSIONS (mm [CONTINUED])

Size DN	Top plate drilling					Flange drilling data				Mounting code
	DD or Keyway		PCD	No. holes	Holes dia.	Number of bolts	Diameter of bolt holes	Diameter of bolt circle	Diameter of bolts (imperial)	
(mm)	(inch)									
80	11.11	7/16	83	4	11	4	19.1	152	5/8-11UNC	BAC
100	12.70	1/2	83	4	11	8	19.1	191	5/8-11UNC	BAD
150	12.70	1/2	127	4	14	8	22.2	241	3/4-10UNC	CAD
150*	15.88	5/8	127	4	14	8	22.2	241	3/4-10UNC	CAE
200	6.35 x 6.35 x 41	1/4 x 1/4 x 1 5/8	127	4	14	8	22.2	298	3/4-10UNC	CAF
250	6.35 x 6.35 x 41	1/4 x 1/4 x 1 3/8	127	4	14	12	25.4	362	7/8-9UNC	CAF
250*	7.94 x 7.94 x 67	5/16 x 5/16 x 2 5/8	127	4	14	12	25.4	362	7/8-9UNC	CAG
300	7.94 x 7.94 x 67	5/16 x 5/16 x 2 5/8	165	4	21	12	25.4	432	7/8-9UNC	DAG
350	9.53 x 9.53 x 67	3/8 x 3/8 x 2 3/8	165	4	21	12	28.6	476	1-8UNC	DAH
400	9.53 x 9.53 x 67	3/8 x 3/8 x 2 3/8	165	4	21	16	28.6	540	1-8UNC	DAH
450	12.70 x 9.53 x 105	1/2 x 3/8 x 4 1/8	165	4	21	16	31.8	578	1 1/8-8UN	DAJ
500	12.70 x 9.53 x 102	1/2 x 3/8 x 4	165	4	21	20	31.8	635	1 1/8-8UN	DAK
600	12.70 x 9.53 x 102	1/2 x 3/8 x 4	165	4	21	20	34.9	749	1 1/4-8UN	DAK

\* E.N.P. discs require larger upper shaft connection diameters on DN 150 and DN 250 valve sizes for UHMWPE seat trims.

N/A = not applicable

# KEYSTONE SERIES 36 AND 37 K-LOK HIGH PERFORMANCE BUTTERFLY VALVES

## METRIC DATA

### DIMENSIONS - DOUBLE FLANGE STYLE

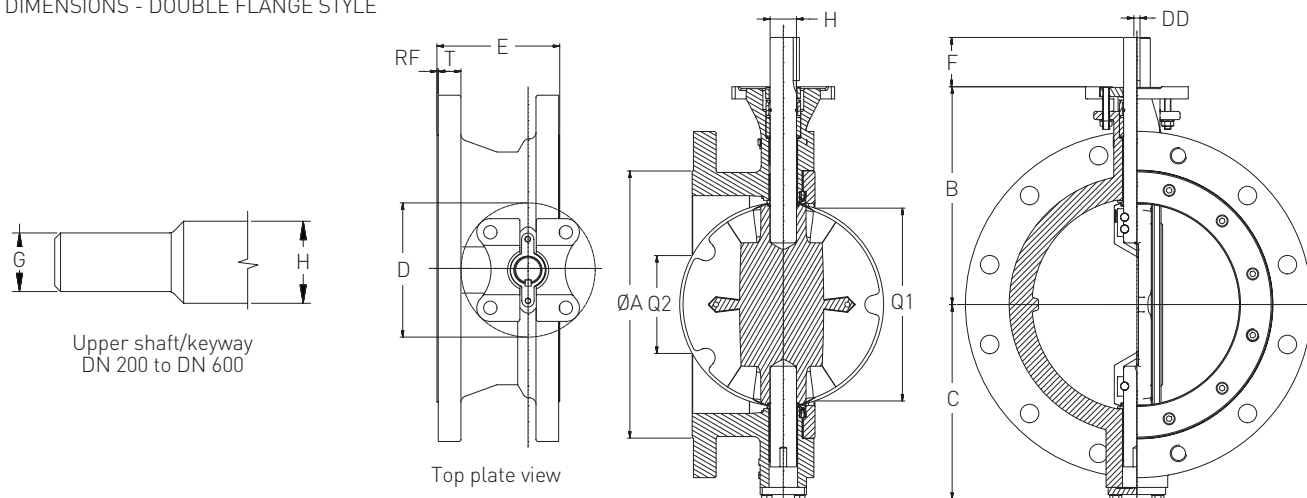

### SERIES 37F, ASME, CLASS 300, DOUBLE FLANGED STYLE, DIMENSIONS (mm)

Size	A	B	C	D	E	F	G	H	Q1	Q2	T	RF
80	127	168	118	105	114	32	N/A	15.88	54	N/A	28.4	2
100	157	191	148	105	127	32	N/A	19.05	80	N/A	31.5	2
150	216	222	181	154	140	32	N/A	22.23	132	N/A	36.5	2
200	270	257	211	154	152	51	N/A	28.58	170	N/A	41.0	2
250	324	289	244	154	165	76	N/A	34.93	223	79	47.5	2
300	381	330	282	208	178	76	34.93	38.10	269	162	51.0	2
350	413	365	321	208	190	108	N/A	47.63	300	184	54.0	2
400	470	408	352	208	216	105	N/A	57.15	345	211	57.0	2
450	533	432	382	208	222	107	N/A	63.50	392	292	60.5	2
500	584	513	415	191	229	165	N/A	69.85	437	352	63.5	2
600	692	594	485	241	267	173	N/A	88.90	525	422	70.0	2

### SERIES 37F, ASME, CLASS 300, DOUBLE FLANGED STYLE, DIMENSIONS (mm [CONTINUED])

Size DN	Top plate drilling					Flange drilling data				Mounting code
	DD or Keyway (mm)	DD or Keyway (inch)	PCD	No. holes	Holes dia.	Number of bolts	Diameter of bolt holes	Diameter of bolt circle	Diameter of bolts (imperial)	
80	11.11	7/16	83	4	11	8	22.2	168	3/4-10UNC	BAC
100	12.70	1/2	83	4	11	8	22.2	200	3/4-10UNC	BAD
150	15.88	5/8	127	4	14	12	22.2	270	3/4-10UNC	CAE
200	6.35 x 6.35 x 41	1/4 x 1/4 x 1 5/8	127	4	14	12	25.4	330	7/8-9UNC	CAF
250	7.94 x 7.94 x 67	5/16 x 5/16 x 2 5/8	127	4	14	16	28.6	387	1-8UNC	CAG
300	7.94 x 7.94 x 67	5/16 x 5/16 x 2 5/8	165	4	21	16	31.8	451	1 1/8-8UN	DAG
350	12.70 x 9.53 x 105	1/2 x 3/8 x 4 1/8	165	4	21	20	31.8	514	1 1/8-8UN	DAJ
400	12.70 x 9.53 x 102	1/2 x 3/8 x 4	165	4	21	20	34.9	572	1 1/4-8UN	DAK
450	15.88 x 15.88 x 102	5/8 x 5/8 x 4	165	4	21	24	34.9	629	1 1/4-8UN	DBA
500	15.88 x 15.88 x 162	5/8 x 5/8 x 6 3/8	203	4	21	24	34.9	686	1 1/4-8UN	LAX
600	22.23 x 22.23 x 144	7/8 x 7/8 x 5 11/16	248	4	27	24	41.3	813	1 1/2-8UN	MAY

N/A = not applicable

# KEYSTONE SERIES 36 AND 37 K-LOK HIGH PERFORMANCE BUTTERFLY VALVES

## IMPERIAL DATA

### DIMENSIONS - WAFER STYLE

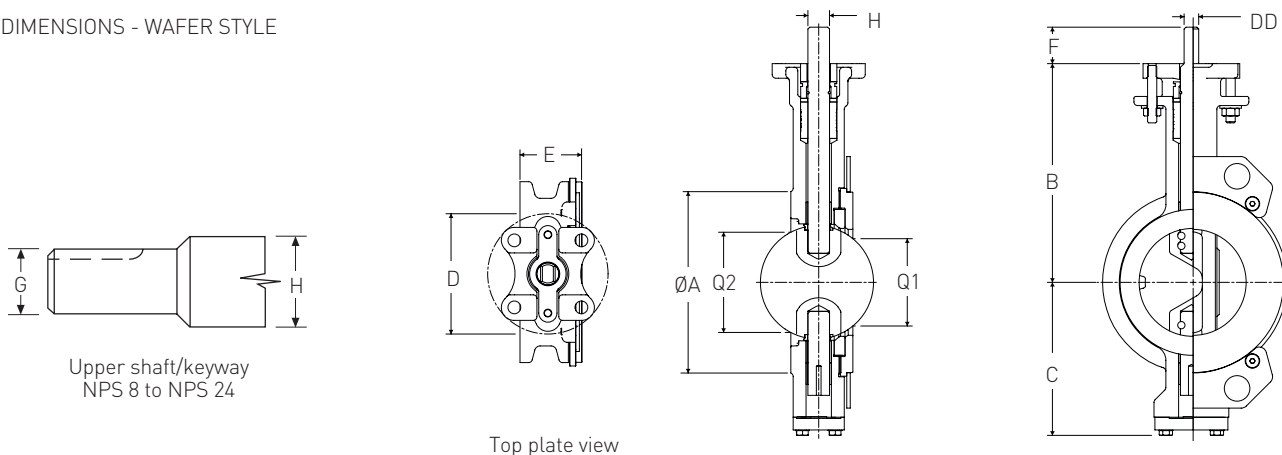

### SERIES 36, ASME CLASS 150, WAFER STYLE, DIMENSIONS (inches)

Size NPS	A	B	C	D	E	F	G	H	Q1	Q2	Top plate drilling				Weight lbs.	Mounting code	
											DD or keyway		PCD	No. holes			Hole dia.
											(inch)	(mm)					
2	4 <sup>5</sup> / <sub>16</sub>	6	4	4 <sup>5</sup> / <sub>32</sub>	2 <sup>3</sup> / <sub>8</sub>	1 <sup>1</sup> / <sub>4</sub>	N/A	9 <sup>1</sup> / <sub>16</sub>	1 <sup>3</sup> / <sub>8</sub>	1 <sup>7</sup> / <sub>8</sub>	3 <sup>8</sup> / <sub></sub>	9.53	3 <sup>1</sup> / <sub>4</sub>	4	7 <sup>1</sup> / <sub>16</sub>	10	BAB
2½	4 <sup>1</sup> / <sub>8</sub>	6	4½	4 <sup>5</sup> / <sub>32</sub>	1 <sup>7</sup> / <sub>8</sub>	1¼	N/A	9 <sup>1</sup> / <sub>16</sub>	2 <sup>3</sup> / <sub>16</sub>	2¼	3 <sup>8</sup> / <sub></sub>	9.53	3 <sup>1</sup> / <sub>4</sub>	4	7 <sup>1</sup> / <sub>16</sub>	8	BAB
3	5	6 <sup>5</sup> / <sub>8</sub>	4 <sup>7</sup> / <sub>8</sub>	4 <sup>5</sup> / <sub>32</sub>	1 <sup>7</sup> / <sub>8</sub>	1¼	N/A	5 <sup>8</sup> / <sub></sub>	2 <sup>1</sup> / <sub>8</sub>	2 <sup>5</sup> / <sub>8</sub>	7 <sup>1</sup> / <sub>16</sub>	11.11	3 <sup>1</sup> / <sub>4</sub>	4	7 <sup>1</sup> / <sub>16</sub>	11	BAC
4	6 <sup>3</sup> / <sub>16</sub>	7½	5¼	4 <sup>5</sup> / <sub>32</sub>	2 <sup>1</sup> / <sub>8</sub>	1¼	N/A	3 <sup>4</sup> / <sub></sub>	3 <sup>3</sup> / <sub>16</sub>	3 <sup>5</sup> / <sub>8</sub>	½	12.70	3 <sup>1</sup> / <sub>4</sub>	4	7 <sup>1</sup> / <sub>16</sub>	18	BAD
5	7 <sup>5</sup> / <sub>16</sub>	7 <sup>7</sup> / <sub>16</sub>	5¾	4 <sup>5</sup> / <sub>32</sub>	2¼	1¼	N/A	3 <sup>4</sup> / <sub></sub>	4 <sup>3</sup> / <sub>8</sub>	4¾	½	12.70	3 <sup>1</sup> / <sub>4</sub>	4	7 <sup>1</sup> / <sub>16</sub>	23	BAD
6	8½	8¾	7 <sup>1</sup> / <sub>16</sub>	6 <sup>1</sup> / <sub>16</sub>	2¼	1¼	¾	7 <sup>8</sup> / <sub></sub>	5¼	5 <sup>9</sup> / <sub>16</sub>	½	12.70	5	4	9 <sup>1</sup> / <sub>16</sub>	30	CAD
6*	8½	8¾	7 <sup>1</sup> / <sub>16</sub>	6 <sup>1</sup> / <sub>16</sub>	2¼	1¼	N/A	7 <sup>8</sup> / <sub></sub>	5¼	5 <sup>9</sup> / <sub>16</sub>	5 <sup>8</sup> / <sub></sub>	15.88	5	4	9 <sup>1</sup> / <sub>16</sub>	31	CAE
8	10 <sup>5</sup> / <sub>8</sub>	10 <sup>1</sup> / <sub>8</sub>	8 <sup>3</sup> / <sub>16</sub>	6 <sup>1</sup> / <sub>16</sub>	2½	2	N/A	1 <sup>7</sup> / <sub>8</sub>	7	7 <sup>3</sup> / <sub>8</sub>	¼ x ¼ x 1 <sup>5</sup> / <sub>8</sub>	6.35 x 6.35 x 41	5	4	9 <sup>1</sup> / <sub>16</sub>	46	CAF
10	12¾	11 <sup>3</sup> / <sub>8</sub>	9 <sup>5</sup> / <sub>8</sub>	6 <sup>1</sup> / <sub>16</sub>	2 <sup>13</sup> / <sub>16</sub>	2	1 <sup>1</sup> / <sub>8</sub>	1 <sup>3</sup> / <sub>8</sub>	9 <sup>1</sup> / <sub>8</sub>	9 <sup>5</sup> / <sub>16</sub>	¼ x ¼ x 1 <sup>5</sup> / <sub>8</sub>	6.35 x 6.35 x 41	5	4	9 <sup>1</sup> / <sub>16</sub>	74	CAF
10*	12¾	11 <sup>3</sup> / <sub>8</sub>	9 <sup>5</sup> / <sub>8</sub>	6 <sup>1</sup> / <sub>16</sub>	2 <sup>13</sup> / <sub>16</sub>	3	N/A	1 <sup>3</sup> / <sub>8</sub>	9 <sup>1</sup> / <sub>8</sub>	9 <sup>5</sup> / <sub>16</sub>	5 <sup>1</sup> / <sub>16</sub> x 5 <sup>1</sup> / <sub>16</sub> x 2 <sup>5</sup> / <sub>8</sub>	7.94 x 7.94 x 67	5	4	9 <sup>1</sup> / <sub>16</sub>	75	CAG
12	15	13	11 <sup>5</sup> / <sub>16</sub>	8 <sup>5</sup> / <sub>32</sub>	3 <sup>3</sup> / <sub>16</sub>	3	1 <sup>3</sup> / <sub>8</sub>	1½	10 <sup>15</sup> / <sub>16</sub>	11 <sup>3</sup> / <sub>16</sub>	5 <sup>1</sup> / <sub>16</sub> x 5 <sup>1</sup> / <sub>16</sub> x 2 <sup>5</sup> / <sub>8</sub>	7.94 x 7.94 x 67	6½	4	13 <sup>1</sup> / <sub>16</sub>	116	DAG
14	16¼	13¾	12 <sup>7</sup> / <sub>8</sub>	8 <sup>5</sup> / <sub>32</sub>	3 <sup>5</sup> / <sub>8</sub>	3	N/A	1 <sup>5</sup> / <sub>8</sub>	11¾	12¼	¾ x ¾ x 2 <sup>5</sup> / <sub>8</sub>	9.53 x 9.53 x 67	6½	4	13 <sup>1</sup> / <sub>16</sub>	133	DAH
16	18½	14½	12¾	8 <sup>5</sup> / <sub>32</sub>	4	3	1 <sup>5</sup> / <sub>8</sub>	1¾	13 <sup>3</sup> / <sub>8</sub>	13 <sup>1</sup> / <sub>8</sub>	¾ x ¾ x 2 <sup>5</sup> / <sub>8</sub>	9.53 x 9.53 x 67	6½	4	13 <sup>1</sup> / <sub>16</sub>	185	DAH
18	21	16	13¾	8 <sup>5</sup> / <sub>32</sub>	4½	4 <sup>1</sup> / <sub>16</sub>	N/A	1 <sup>7</sup> / <sub>8</sub>	15 <sup>9</sup> / <sub>16</sub>	15 <sup>15</sup> / <sub>16</sub>	½ x ¾ x 4 <sup>1</sup> / <sub>8</sub>	12.70 x 9.53 x 105	6½	4	13 <sup>1</sup> / <sub>16</sub>	288	DAJ
20	23	17 <sup>7</sup> / <sub>16</sub>	15 <sup>3</sup> / <sub>16</sub>	8 <sup>7</sup> / <sub>32</sub>	5	4 <sup>5</sup> / <sub>16</sub>	N/A	2¼	17 <sup>9</sup> / <sub>16</sub>	17 <sup>11</sup> / <sub>16</sub>	½ x ¾ x 4	12.70 x 9.53 x 102	6½	4	13 <sup>1</sup> / <sub>16</sub>	376	DAK
24	27¼	19 <sup>11</sup> / <sub>16</sub>	17 <sup>7</sup> / <sub>16</sub>	8 <sup>7</sup> / <sub>32</sub>	6 <sup>1</sup> / <sub>16</sub>	4¼	2¼	2½	20 <sup>5</sup> / <sub>8</sub>	21 <sup>1</sup> / <sub>16</sub>	½ x ¾ x 4	12.70 x 9.53 x 102	6½	4	13 <sup>1</sup> / <sub>16</sub>	592	DAK

\* E.N.P. discs require larger upper shaft connection diameters on NPS 6 and NPS 10 valve sizes for UHMWPE seat trims.  
N/A = not applicable

### SERIES 37, ASME CLASS 300, WAFER STYLE, DIMENSIONS (inches)

Size NPS	A	B	C	D	E	F	G	H	Q1	Q2	Top plate drilling			Tapped lug data			Weight lbs.	Mounting code		
											DD or keyway		PCD	No. holes	Holes dia.	No. holes			PCD	Tap
											(inch)	(mm)								
2	4 <sup>5</sup> / <sub>16</sub>	6	4	4 <sup>5</sup> / <sub>32</sub>	2 <sup>3</sup> / <sub>8</sub>	1¼	N/A	9 <sup>1</sup> / <sub>16</sub>	1 <sup>3</sup> / <sub>8</sub>	1 <sup>7</sup> / <sub>8</sub>	3 <sup>8</sup> / <sub></sub>	9.53	3 <sup>1</sup> / <sub>4</sub>	4	7 <sup>1</sup> / <sub>16</sub>	-	-	-	10	BAB
2½	4 <sup>1</sup> / <sub>8</sub>	6	4½	4 <sup>5</sup> / <sub>32</sub>	1 <sup>7</sup> / <sub>8</sub>	1¼	N/A	9 <sup>1</sup> / <sub>16</sub>	2 <sup>3</sup> / <sub>16</sub>	2¼	3 <sup>8</sup> / <sub></sub>	9.53	3 <sup>1</sup> / <sub>4</sub>	4	7 <sup>1</sup> / <sub>16</sub>	-	-	-	9	BAB
3	5	6 <sup>5</sup> / <sub>8</sub>	4 <sup>7</sup> / <sub>8</sub>	4 <sup>5</sup> / <sub>32</sub>	1 <sup>7</sup> / <sub>8</sub>	1¼	N/A	5 <sup>8</sup> / <sub></sub>	1 <sup>1</sup> / <sub>16</sub>	2 <sup>5</sup> / <sub>8</sub>	7 <sup>1</sup> / <sub>16</sub>	11.11	3 <sup>1</sup> / <sub>4</sub>	4	7 <sup>1</sup> / <sub>16</sub>	-	-	-	11	BAC
4	6 <sup>3</sup> / <sub>16</sub>	7½	5 <sup>7</sup> / <sub>32</sub>	4 <sup>5</sup> / <sub>32</sub>	2 <sup>1</sup> / <sub>8</sub>	1¼	N/A	3 <sup>4</sup> / <sub></sub>	3 <sup>3</sup> / <sub>16</sub>	3 <sup>5</sup> / <sub>8</sub>	½	12.70	3 <sup>1</sup> / <sub>4</sub>	4	7 <sup>1</sup> / <sub>16</sub>	-	-	-	18	BAD
5	7 <sup>5</sup> / <sub>16</sub>	7 <sup>7</sup> / <sub>16</sub>	5¾	4 <sup>5</sup> / <sub>32</sub>	2 <sup>5</sup> / <sub>16</sub>	1¼	N/A	3 <sup>4</sup> / <sub></sub>	4 <sup>5</sup> / <sub>16</sub>	4¾	½	12.70	3 <sup>1</sup> / <sub>4</sub>	4	7 <sup>1</sup> / <sub>16</sub>	-	-	-	23	BAD
6	8½	8¾	7 <sup>1</sup> / <sub>16</sub>	6 <sup>1</sup> / <sub>16</sub>	2 <sup>5</sup> / <sub>16</sub>	1¼	N/A	7 <sup>8</sup> / <sub></sub>	5¼	5 <sup>9</sup> / <sub>16</sub>	5 <sup>8</sup> / <sub></sub>	15.88	5	4	9 <sup>1</sup> / <sub>16</sub>	-	-	-	30	CAE
8	10 <sup>5</sup> / <sub>8</sub>	10 <sup>1</sup> / <sub>8</sub>	8 <sup>3</sup> / <sub>16</sub>	6 <sup>1</sup> / <sub>16</sub>	2 <sup>7</sup> / <sub>8</sub>	2	N/A	1 <sup>7</sup> / <sub>8</sub>	6¾	7 <sup>3</sup> / <sub>8</sub>	¼ x ¼ x 1 <sup>5</sup> / <sub>8</sub>	6.35 x 6.35 x 41	5	4	9 <sup>1</sup> / <sub>16</sub>	-	-	-	55	CAF
10	12¾	11 <sup>3</sup> / <sub>8</sub>	9 <sup>5</sup> / <sub>8</sub>	6 <sup>1</sup> / <sub>16</sub>	3¼	3	N/A	1 <sup>3</sup> / <sub>8</sub>	8 <sup>13</sup> / <sub>16</sub>	9 <sup>5</sup> / <sub>16</sub>	5 <sup>1</sup> / <sub>16</sub> x 5 <sup>1</sup> / <sub>16</sub> x 2 <sup>5</sup> / <sub>8</sub>	7.94 x 7.94 x 67	5	4	9 <sup>1</sup> / <sub>16</sub>	4	15¼	1-8UNC	93	CAG
12	15	13	11 <sup>5</sup> / <sub>16</sub>	8 <sup>5</sup> / <sub>32</sub>	3 <sup>3</sup> / <sub>16</sub>	3	1 <sup>3</sup> / <sub>8</sub>	1½	10 <sup>15</sup> / <sub>16</sub>	11 <sup>3</sup> / <sub>16</sub>	5 <sup>1</sup> / <sub>16</sub> x 5 <sup>1</sup> / <sub>16</sub> x 2 <sup>5</sup> / <sub>8</sub>	7.94 x 7.94 x 67	6½	4	13 <sup>1</sup> / <sub>16</sub>	-	-	-	127	DAG
14	16¼	14 <sup>3</sup> / <sub>8</sub>	12 <sup>11</sup> / <sub>16</sub>	8 <sup>5</sup> / <sub>32</sub>	4 <sup>5</sup> / <sub>8</sub>	4¼	N/A	1 <sup>5</sup> / <sub>8</sub>	11 <sup>13</sup> / <sub>16</sub>	11 <sup>15</sup> / <sub>16</sub>	½ x ¾ x 4 <sup>1</sup> / <sub>8</sub>	12.70 x 9.53 x 105	6½	4	13 <sup>1</sup> / <sub>16</sub>	4	20¼	1 <sup>1</sup> / <sub>8</sub> -8UN	202	DAJ
16	18½	16 <sup>1</sup> / <sub>16</sub>	13 <sup>7</sup> / <sub>8</sub>	8 <sup>5</sup> / <sub>32</sub>	5¼	4 <sup>1</sup> / <sub>8</sub>	N/A	2¼	13 <sup>3</sup> / <sub>16</sub>	13 <sup>1</sup> / <sub>16</sub>	½ x ¾ x 4	12.70 x 9.53 x 102	6½	4	13 <sup>1</sup> / <sub>16</sub>	4	22½	1¼-8UN	270	DAK
18	21	17	15 <sup>1</sup> / <sub>16</sub>	8 <sup>5</sup> / <sub>32</sub>	5 <sup>7</sup> / <sub>8</sub>	4 <sup>7</sup> / <sub>32</sub>	N/A	2½	15 <sup>5</sup> / <sub>8</sub>	15½	5 <sup>8</sup> / <sub></sub> x 5 <sup>8</sup> / <sub></sub> x 4	15.88 x 15.88 x 102	6½	4	13 <sup>1</sup> / <sub>16</sub>	4	24¾	1¼-8UN	373	DBA
20	23	20 <sup>3</sup> / <sub>16</sub>	16 <sup>3</sup> / <sub>8</sub>	7½	6¼	6½	N/A	2¾	17¼	17¾	5 <sup>8</sup> / <sub></sub> x 5 <sup>8</sup> / <sub></sub> x 6 <sup>3</sup> / <sub>8</sub>	15.88 x 15.88 x 162	8	4	13 <sup>1</sup> / <sub>16</sub>	4	27	1¼-8UN	482	LAX
24	27¼	23 <sup>7</sup> / <sub>8</sub>	19 <sup>1</sup> / <sub>8</sub>	9½	7 <sup>8</sup> / <sub></sub>	6 <sup>13</sup> / <sub>16</sub>	N/A	3½	20 <sup>11</sup> / <sub>16</sub>	20 <sup>19</sup> / <sub>16</sub>	7 <sup>8</sup> / <sub></sub> x 7 <sup>8</sup> / <sub></sub> x 5 <sup>1</sup> / <sub>16</sub>	22.23 x 22.23 x 144	9¾	4	1 <sup>1</sup> / <sub>16</sub>	4	32	1½-8UN	800	MAY

N/A = not applicable

# KEYSTONE SERIES 36 AND 37 K-LOK HIGH PERFORMANCE BUTTERFLY VALVES

## IMPERIAL DATA

### DIMENSIONS - LUG STYLE

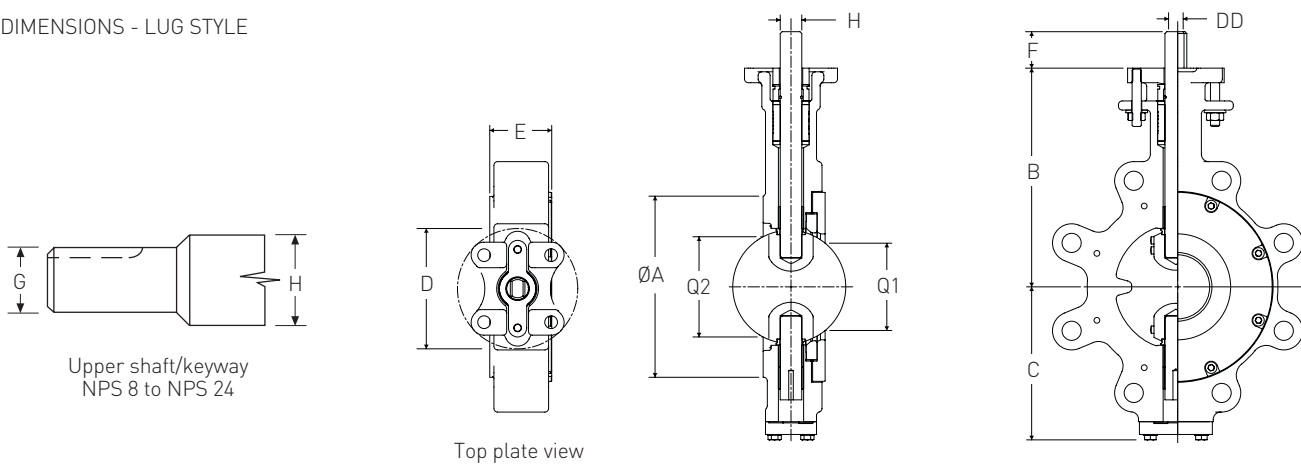

Upper shaft/keyway  
NPS 8 to NPS 24

Top plate view

### SERIES 36, ASME CLASS 150, LUG STYLE, DIMENSIONS (inches)

Size NPS												Top plate drilling				Tapped lug data			Weight lbs.	Mount- ing code
	A	B	C	D	E	F	G	H	Q1	Q2	DD or keyway (inch)	(mm)	PCD	No. holes	Holes dia.	No. holes	PCD	Tap		
2	4 <sup>15</sup> / <sub>32</sub>	6	4	4 <sup>5</sup> / <sub>32</sub>	2 <sup>3</sup> / <sub>8</sub>	1 <sup>1</sup> / <sub>4</sub>	N/A	7 <sup>1</sup> / <sub>16</sub>	1 <sup>3</sup> / <sub>8</sub>	1 <sup>7</sup> / <sub>8</sub>	3 <sup>8</sup> / <sub>16</sub>	9.53	3 <sup>1</sup> / <sub>4</sub>	4	7 <sup>1</sup> / <sub>16</sub>	4	4 <sup>3</sup> / <sub>4</sub>	5 <sup>8</sup> -11UNC	12	BAB
2 <sup>1</sup> / <sub>2</sub>	4 <sup>3</sup> / <sub>4</sub>	6	4 <sup>11</sup> / <sub>32</sub>	4 <sup>5</sup> / <sub>32</sub>	1 <sup>7</sup> / <sub>8</sub>	1 <sup>1</sup> / <sub>4</sub>	N/A	7 <sup>1</sup> / <sub>16</sub>	2 <sup>3</sup> / <sub>16</sub>	2 <sup>1</sup> / <sub>4</sub>	3 <sup>8</sup> / <sub>16</sub>	9.53	3 <sup>1</sup> / <sub>4</sub>	4	7 <sup>1</sup> / <sub>16</sub>	4	5 <sup>1</sup> / <sub>2</sub>	5 <sup>8</sup> -11UNC	12	BAB
3	5 <sup>7</sup> / <sub>32</sub>	6 <sup>5</sup> / <sub>8</sub>	4 <sup>31</sup> / <sub>32</sub>	4 <sup>5</sup> / <sub>32</sub>	1 <sup>7</sup> / <sub>8</sub>	1 <sup>1</sup> / <sub>4</sub>	N/A	5 <sup>8</sup> / <sub>16</sub>	2 <sup>1</sup> / <sub>8</sub>	2 <sup>5</sup> / <sub>8</sub>	7 <sup>1</sup> / <sub>16</sub>	11.11	3 <sup>1</sup> / <sub>4</sub>	4	7 <sup>1</sup> / <sub>16</sub>	4	6	5 <sup>8</sup> -11UNC	15	BAC
4	6 <sup>15</sup> / <sub>32</sub>	7 <sup>1</sup> / <sub>2</sub>	5 <sup>1</sup> / <sub>4</sub>	4 <sup>5</sup> / <sub>32</sub>	2 <sup>1</sup> / <sub>8</sub>	1 <sup>1</sup> / <sub>4</sub>	N/A	3 <sup>4</sup> / <sub>16</sub>	3 <sup>3</sup> / <sub>16</sub>	3 <sup>5</sup> / <sub>8</sub>	1 <sup>1</sup> / <sub>2</sub>	12.70	3 <sup>1</sup> / <sub>4</sub>	4	7 <sup>1</sup> / <sub>16</sub>	8	7 <sup>1</sup> / <sub>2</sub>	5 <sup>8</sup> -11UNC	23	BAD
5	7 <sup>19</sup> / <sub>32</sub>	7 <sup>7</sup> / <sub>16</sub>	5 <sup>3</sup> / <sub>4</sub>	4 <sup>5</sup> / <sub>32</sub>	2 <sup>1</sup> / <sub>4</sub>	1 <sup>1</sup> / <sub>4</sub>	N/A	3 <sup>4</sup> / <sub>16</sub>	4 <sup>3</sup> / <sub>8</sub>	4 <sup>3</sup> / <sub>4</sub>	1 <sup>1</sup> / <sub>2</sub>	12.70	3 <sup>1</sup> / <sub>4</sub>	4	7 <sup>1</sup> / <sub>16</sub>	8	8 <sup>1</sup> / <sub>2</sub>	3 <sup>4</sup> -10UNC	30	BAD
6	8 <sup>7</sup> / <sub>8</sub>	8 <sup>3</sup> / <sub>4</sub>	5 <sup>7</sup> / <sub>8</sub>	6 <sup>1</sup> / <sub>16</sub>	2 <sup>1</sup> / <sub>4</sub>	1 <sup>1</sup> / <sub>4</sub>	3 <sup>4</sup> / <sub>16</sub>	7 <sup>8</sup> / <sub>16</sub>	5 <sup>1</sup> / <sub>4</sub>	5 <sup>7</sup> / <sub>16</sub>	1 <sup>1</sup> / <sub>2</sub>	12.70	5	4	7 <sup>1</sup> / <sub>16</sub>	8	9 <sup>1</sup> / <sub>2</sub>	3 <sup>4</sup> -10UNC	40	CAD
6*	8 <sup>7</sup> / <sub>8</sub>	8 <sup>3</sup> / <sub>4</sub>	5 <sup>7</sup> / <sub>8</sub>	6 <sup>1</sup> / <sub>16</sub>	2 <sup>1</sup> / <sub>4</sub>	1 <sup>1</sup> / <sub>4</sub>	N/A	7 <sup>8</sup> / <sub>16</sub>	5 <sup>1</sup> / <sub>4</sub>	5 <sup>7</sup> / <sub>16</sub>	5 <sup>8</sup> / <sub>16</sub>	15.88	5	4	7 <sup>1</sup> / <sub>16</sub>	8	9 <sup>1</sup> / <sub>2</sub>	3 <sup>4</sup> -10UNC	40	CAE
8	10 <sup>5</sup> / <sub>8</sub>	10 <sup>5</sup> / <sub>8</sub>	8 <sup>5</sup> / <sub>16</sub>	6 <sup>1</sup> / <sub>16</sub>	2 <sup>1</sup> / <sub>2</sub>	2	N/A	1 <sup>1</sup> / <sub>8</sub>	7	7 <sup>3</sup> / <sub>8</sub>	1 <sup>1</sup> / <sub>4</sub> x 1 <sup>1</sup> / <sub>4</sub> x 1 <sup>5</sup> / <sub>8</sub>	6.35 x 6.35 x 41	5	4	7 <sup>1</sup> / <sub>16</sub>	8	11 <sup>3</sup> / <sub>4</sub>	3 <sup>4</sup> -10UNC	60	CAF
10	12 <sup>3</sup> / <sub>4</sub>	11 <sup>3</sup> / <sub>8</sub>	9 <sup>5</sup> / <sub>8</sub>	6 <sup>1</sup> / <sub>16</sub>	2 <sup>13</sup> / <sub>16</sub>	2	1 <sup>1</sup> / <sub>8</sub>	1 <sup>3</sup> / <sub>8</sub>	9 <sup>1</sup> / <sub>8</sub>	9 <sup>5</sup> / <sub>16</sub>	1 <sup>1</sup> / <sub>4</sub> x 1 <sup>1</sup> / <sub>4</sub> x 1 <sup>5</sup> / <sub>8</sub>	6.35 x 6.35 x 41	5	4	7 <sup>1</sup> / <sub>16</sub>	12	14 <sup>1</sup> / <sub>4</sub>	7 <sup>8</sup> -9UNC	89	CAF
10*	12 <sup>3</sup> / <sub>4</sub>	11 <sup>3</sup> / <sub>8</sub>	9 <sup>5</sup> / <sub>8</sub>	6 <sup>1</sup> / <sub>16</sub>	2 <sup>13</sup> / <sub>16</sub>	3	N/A	1 <sup>3</sup> / <sub>8</sub>	9 <sup>1</sup> / <sub>8</sub>	9 <sup>5</sup> / <sub>16</sub>	5 <sup>1</sup> / <sub>16</sub> x 5 <sup>1</sup> / <sub>16</sub> x 2 <sup>5</sup> / <sub>8</sub>	7.94 x 7.94 x 67	5	4	7 <sup>1</sup> / <sub>16</sub>	12	14 <sup>1</sup> / <sub>4</sub>	7 <sup>8</sup> -9UNC	90	CAG
12	15	13	10 <sup>19</sup> / <sub>32</sub>	8 <sup>5</sup> / <sub>32</sub>	3 <sup>3</sup> / <sub>16</sub>	3	1 <sup>3</sup> / <sub>8</sub>	1 <sup>1</sup> / <sub>2</sub>	10 <sup>15</sup> / <sub>16</sub>	11 <sup>3</sup> / <sub>16</sub>	5 <sup>1</sup> / <sub>16</sub> x 5 <sup>1</sup> / <sub>16</sub> x 2 <sup>5</sup> / <sub>8</sub>	7.94 x 7.94 x 67	6 <sup>1</sup> / <sub>2</sub>	4	1 <sup>3</sup> / <sub>16</sub>	12	17	7 <sup>8</sup> -9UNC	147	DAG
14	16 <sup>1</sup> / <sub>4</sub>	13 <sup>3</sup> / <sub>4</sub>	11 <sup>27</sup> / <sub>32</sub>	8 <sup>5</sup> / <sub>32</sub>	3 <sup>5</sup> / <sub>8</sub>	3	N/A	1 <sup>5</sup> / <sub>8</sub>	11 <sup>1</sup> / <sub>4</sub>	12 <sup>1</sup> / <sub>4</sub>	3 <sup>8</sup> x 3 <sup>8</sup> x 2 <sup>5</sup> / <sub>8</sub>	9.53 x 9.53 x 67	6 <sup>1</sup> / <sub>2</sub>	4	1 <sup>3</sup> / <sub>16</sub>	12	18 <sup>3</sup> / <sub>4</sub>	1-8UNC	162	DAH
16	18 <sup>1</sup> / <sub>2</sub>	14 <sup>1</sup> / <sub>2</sub>	12 <sup>21</sup> / <sub>32</sub>	8 <sup>5</sup> / <sub>32</sub>	4	3	1 <sup>5</sup> / <sub>8</sub>	1 <sup>3</sup> / <sub>4</sub>	13 <sup>3</sup> / <sub>8</sub>	14 <sup>1</sup> / <sub>8</sub>	3 <sup>8</sup> x 3 <sup>8</sup> x 2 <sup>5</sup> / <sub>8</sub>	9.53 x 9.53 x 67	6 <sup>1</sup> / <sub>2</sub>	4	1 <sup>3</sup> / <sub>16</sub>	16	21 <sup>1</sup> / <sub>4</sub>	1-8UNC	213	DAH
18	21	16	13 <sup>3</sup> / <sub>4</sub>	8 <sup>5</sup> / <sub>32</sub>	4 <sup>1</sup> / <sub>2</sub>	4 <sup>1</sup> / <sub>16</sub>	N/A	1 <sup>7</sup> / <sub>8</sub>	15 <sup>5</sup> / <sub>16</sub>	15 <sup>15</sup> / <sub>16</sub>	1 <sup>1</sup> / <sub>2</sub> x 3 <sup>8</sup> x 4 <sup>1</sup> / <sub>16</sub>	12.70 x 9.53 x 105	6 <sup>1</sup> / <sub>2</sub>	4	1 <sup>3</sup> / <sub>16</sub>	16	22 <sup>3</sup> / <sub>4</sub>	1 <sup>1</sup> / <sub>8</sub> -8UN	350	DAJ
20	23	17 <sup>7</sup> / <sub>16</sub>	15 <sup>3</sup> / <sub>16</sub>	8 <sup>7</sup> / <sub>32</sub>	5	4 <sup>3</sup> / <sub>16</sub>	N/A	2 <sup>1</sup> / <sub>4</sub>	17 <sup>5</sup> / <sub>16</sub>	17 <sup>11</sup> / <sub>16</sub>	1 <sup>1</sup> / <sub>2</sub> x 3 <sup>8</sup> x 4	12.70 x 9.53 x 102	6 <sup>1</sup> / <sub>2</sub>	4	1 <sup>3</sup> / <sub>16</sub>	20	25	1 <sup>1</sup> / <sub>8</sub> -8UN	458	DAK
24	27 <sup>1</sup> / <sub>4</sub>	19 <sup>11</sup> / <sub>16</sub>	17 <sup>7</sup> / <sub>16</sub>	8 <sup>7</sup> / <sub>32</sub>	6 <sup>1</sup> / <sub>16</sub>	4 <sup>1</sup> / <sub>4</sub>	2 <sup>1</sup> / <sub>4</sub>	2 <sup>1</sup> / <sub>2</sub>	20 <sup>5</sup> / <sub>8</sub>	21 <sup>1</sup> / <sub>16</sub>	1 <sup>1</sup> / <sub>2</sub> x 3 <sup>8</sup> x 4	12.70 x 9.53 x 102	6 <sup>1</sup> / <sub>2</sub>	4	1 <sup>3</sup> / <sub>16</sub>	20	29 <sup>1</sup> / <sub>2</sub>	1 <sup>1</sup> / <sub>4</sub> -8UN	704	DAK

\* E.N.P. discs require larger upper shaft connection diameters on NPS 6 and NPS 10 valve sizes for UHMWPE seat trims.  
N/A = not applicable

### SERIES 37, ASME CLASS 300, LUG STYLE, DIMENSIONS (inches)

Size NPS												Top plate drilling				Tapped lug data			Weight lbs.	Mount- ing code
	A	B	C	D	E	F	G	H	Q1	Q2	DD or keyway (inch)	(mm)	PCD	No. holes	Holes dia.	No. holes	PCD	Tap		
2	4 <sup>15</sup> / <sub>32</sub>	6	3 <sup>31</sup> / <sub>32</sub>	4 <sup>5</sup> / <sub>32</sub>	2 <sup>3</sup> / <sub>8</sub>	1 <sup>1</sup> / <sub>4</sub>	N/A	7 <sup>1</sup> / <sub>16</sub>	1 <sup>3</sup> / <sub>8</sub>	1 <sup>7</sup> / <sub>8</sub>	3 <sup>8</sup> / <sub>16</sub>	9.53	3 <sup>1</sup> / <sub>4</sub>	4	7 <sup>1</sup> / <sub>16</sub>	8	5	5 <sup>8</sup> -11UNC	13	BAB
2 <sup>1</sup> / <sub>2</sub>	4 <sup>13</sup> / <sub>16</sub>	6	4 <sup>11</sup> / <sub>32</sub>	4 <sup>5</sup> / <sub>32</sub>	1 <sup>7</sup> / <sub>8</sub>	1 <sup>1</sup> / <sub>4</sub>	N/A	7 <sup>1</sup> / <sub>16</sub>	2 <sup>3</sup> / <sub>16</sub>	2 <sup>1</sup> / <sub>4</sub>	3 <sup>8</sup> / <sub>16</sub>	9.53	3 <sup>1</sup> / <sub>4</sub>	4	7 <sup>1</sup> / <sub>16</sub>	8	5 <sup>7</sup> / <sub>8</sub>	3 <sup>4</sup> -10UNC	16	BAB
3	5 <sup>5</sup> / <sub>16</sub>	6 <sup>5</sup> / <sub>8</sub>	4 <sup>21</sup> / <sub>32</sub>	4 <sup>5</sup> / <sub>32</sub>	1 <sup>7</sup> / <sub>8</sub>	1 <sup>1</sup> / <sub>4</sub>	N/A	5 <sup>8</sup> / <sub>16</sub>	2 <sup>1</sup> / <sub>8</sub>	2 <sup>5</sup> / <sub>8</sub>	7 <sup>1</sup> / <sub>16</sub>	11.11	3 <sup>1</sup> / <sub>4</sub>	4	7 <sup>1</sup> / <sub>16</sub>	8	6 <sup>5</sup> / <sub>8</sub>	3 <sup>4</sup> -10UNC	18	BAC
4	6 <sup>15</sup> / <sub>32</sub>	7 <sup>1</sup> / <sub>2</sub>	5 <sup>1</sup> / <sub>4</sub>	4 <sup>5</sup> / <sub>32</sub>	2 <sup>1</sup> / <sub>8</sub>	1 <sup>1</sup> / <sub>4</sub>	N/A	3 <sup>4</sup> / <sub>16</sub>	3 <sup>3</sup> / <sub>16</sub>	3 <sup>5</sup> / <sub>8</sub>	1 <sup>1</sup> / <sub>2</sub>	12.70	3 <sup>1</sup> / <sub>4</sub>	4	7 <sup>1</sup> / <sub>16</sub>	8	7 <sup>7</sup> / <sub>8</sub>	3 <sup>4</sup> -10UNC	25	BAD
5	7 <sup>5</sup> / <sub>8</sub>	7 <sup>7</sup> / <sub>16</sub>	5 <sup>3</sup> / <sub>4</sub>	4 <sup>5</sup> / <sub>32</sub>	2 <sup>5</sup> / <sub>16</sub>	1 <sup>1</sup> / <sub>4</sub>	N/A	3 <sup>4</sup> / <sub>16</sub>	4 <sup>5</sup> / <sub>16</sub>	4 <sup>3</sup> / <sub>4</sub>	1 <sup>1</sup> / <sub>2</sub>	12.70	3 <sup>1</sup> / <sub>4</sub>	4	7 <sup>1</sup> / <sub>16</sub>	8	9 <sup>1</sup> / <sub>4</sub>	3 <sup>4</sup> -10UNC	34	BAD
6	8 <sup>7</sup> / <sub>8</sub>	8 <sup>3</sup> / <sub>4</sub>	6 <sup>7</sup> / <sub>8</sub>	6 <sup>1</sup> / <sub>16</sub>	2 <sup>5</sup> / <sub>16</sub>	1 <sup>1</sup> / <sub>4</sub>	N/A	7 <sup>8</sup> / <sub>16</sub>	5 <sup>1</sup> / <sub>4</sub>	5 <sup>7</sup> / <sub>16</sub>	5 <sup>8</sup> / <sub>16</sub>	15.88	5	4	7 <sup>1</sup> / <sub>16</sub>	12	10 <sup>5</sup> / <sub>8</sub>	3 <sup>4</sup> -10UNC	45	CAE
8	11 <sup>5</sup> / <sub>32</sub>	10 <sup>1</sup> / <sub>8</sub>	8 <sup>5</sup> / <sub>16</sub>	6 <sup>1</sup> / <sub>16</sub>	2 <sup>7</sup> / <sub>8</sub>	2	N/A	1 <sup>1</sup> / <sub>8</sub>	6 <sup>3</sup> / <sub>4</sub>	7 <sup>3</sup> / <sub>8</sub>	1 <sup>1</sup> / <sub>4</sub> x 1 <sup>1</sup> / <sub>4</sub> x 1 <sup>5</sup> / <sub>8</sub>	6.35 x 6.35 x 41	5	4	7 <sup>1</sup> / <sub>16</sub>	12	13	7 <sup>8</sup> -9UNC	80	CAF
10	12 <sup>3</sup> / <sub>4</sub>	11 <sup>3</sup> / <sub>8</sub>	9 <sup>5</sup> / <sub>8</sub>	6 <sup>1</sup> / <sub>16</sub>	3 <sup>1</sup> / <sub>4</sub>	3	N/A	1 <sup>3</sup> / <sub>8</sub>	8 <sup>13</sup> / <sub>16</sub>	9 <sup>9</sup> / <sub>16</sub>	5 <sup>1</sup> / <sub>16</sub> x 5 <sup>1</sup> / <sub>16</sub> x 2 <sup>5</sup> / <sub>8</sub>	7.94 x 7.94 x 67	5	4	7 <sup>1</sup> / <sub>16</sub>	16	15 <sup>1</sup> / <sub>4</sub>	1-8UNC	120	CAG
12	15	13	11 <sup>27</sup> / <sub>32</sub>	8 <sup>5</sup> / <sub>32</sub>	3 <sup>5</sup> / <sub>8</sub>	3	1 <sup>3</sup> / <sub>8</sub>	1 <sup>1</sup> / <sub>2</sub>	10 <sup>5</sup> / <sub>8</sub>	11 <sup>3</sup> / <sub>16</sub>	5 <sup>1</sup> / <sub>16</sub> x 5 <sup>1</sup> / <sub>16</sub> x 2 <sup>5</sup> / <sub>8</sub>	7.94 x 7.94 x 67	6 <sup>1</sup> / <sub>2</sub>	4	1 <sup>3</sup> / <sub>16</sub>	16	17 <sup>3</sup> / <sub>4</sub>	1 <sup>1</sup> / <sub>8</sub> -8UN	179	DAG
14	16 <sup>1</sup> / <sub>4</sub>	14 <sup>3</sup> / <sub>4</sub>	12 <sup>21</sup> / <sub>32</sub>	8 <sup>5</sup> / <sub>32</sub>	4 <sup>5</sup> / <sub>8</sub>	4 <sup>1</sup> / <sub>4</sub>	N/A	1 <sup>7</sup> / <sub>8</sub>	11 <sup>13</sup> / <sub>16</sub>	11 <sup>15</sup> / <sub>16</sub>	1 <sup>1</sup> / <sub>2</sub> x 3 <sup>8</sup> x 4 <sup>1</sup> / <sub>16</sub>	12.70 x 9.53 x 105	6 <sup>1</sup> / <sub>2</sub>	4	1 <sup>3</sup> / <sub>16</sub>	20	20 <sup>1</sup> / <sub>4</sub>	1 <sup>1</sup> / <sub>8</sub> -8UN	293	DAJ
16	18 <sup>1</sup> / <sub>2</sub>	16 <sup>1</sup> / <sub>16</sub>	13 <sup>27</sup> / <sub>32</sub>	8 <sup>5</sup> / <sub>32</sub>	5 <sup>1</sup> / <sub>4</sub>	4 <sup>1</sup> / <sub>8</sub>	N/A	2 <sup>1</sup> / <sub>4</sub>	13 <sup>13</sup> / <sub>16</sub>	13 <sup>11</sup> / <sub>16</sub>	1 <sup>1</sup> / <sub>2</sub> x 3 <sup>8</sup> x 4	12.70 x 9.53 x 102	6 <sup>1</sup> / <sub>2</sub>	4	1 <sup>3</sup> / <sub>16</sub>	20	22 <sup>1</sup> / <sub>2</sub>	1 <sup>1</sup> / <sub>4</sub> -8UN	390	DAK
18	21	17	15 <sup>1</sup> / <sub>32</sub>	8 <sup>5</sup> / <sub>32</sub>	5 <sup>7</sup> / <sub>8</sub>	4 <sup>7</sup> / <sub>32</sub>	N/A	2 <sup>1</sup> / <sub>2</sub>	15 <sup>7</sup> / <sub>16</sub>	15 <sup>1</sup> / <sub>2</sub>	5 <sup>8</sup> x 5 <sup>8</sup> x 4	15.88 x 15.88 x 102	6 <sup>1</sup> / <sub>2</sub>	4	1 <sup>3</sup> / <sub>16</sub>	24	24 <sup>3</sup> / <sub>4</sub>	1 <sup>1</sup> / <sub>4</sub> -8UN	524	DBA
20	23	20 <sup>3</sup> / <sub>16</sub>	16 <sup>11</sup> / <sub>32</sub>	7 <sup>1</sup> / <sub>2</sub>	6 <sup>1</sup> / <sub>4</sub>	6 <sup>1</sup> / <sub>2</sub>	N/A	2 <sup>3</sup> / <sub>4</sub>	17 <sup>1</sup> / <sub>4</sub>	17 <sup>3</sup> / <sub>8</sub>	5 <sup>8</sup> x 5 <sup>8</sup> x 6 <sup>3</sup> / <sub>8</sub>	15.88 x 15.88 x 162	8	4	1 <sup>3</sup> / <sub>16</sub>	24	27	1 <sup>1</sup> / <sub>4</sub> -8UN	657	LAX
24	27 <sup>1</sup> / <sub>4</sub>	23 <sup>3</sup> / <sub>8</sub>	19 <sup>3</sup> / <sub>32</sub>	9 <sup>1</sup> / <sub>2</sub>	7 <sup>1</sup> / <sub>8</sub>	6 <sup>13</sup> / <sub>16</sub>	N/A	3 <sup>1</sup> / <sub>2</sub>	20 <sup>11</sup> / <sub>16</sub>	20 <sup>13</sup> / <sub>16</sub>	7 <sup>8</sup> x 7 <sup>8</sup> x 5 <sup>1</sup> / <sub>16</sub>	22.23 x 22.23 x 144	9 <sup>3</sup> / <sub>4</sub>	4	1 <sup>1</sup> / <sub>16</sub>	24	32	1 <sup>1</sup> / <sub>2</sub> -8UN	1076	MAY

N/A = not applicable

# KEYSTONE SERIES 36 AND 37 K-LOK HIGH PERFORMANCE BUTTERFLY VALVES

## IMPERIAL DATA

### DIMENSIONS - DOUBLE FLANGE STYLE

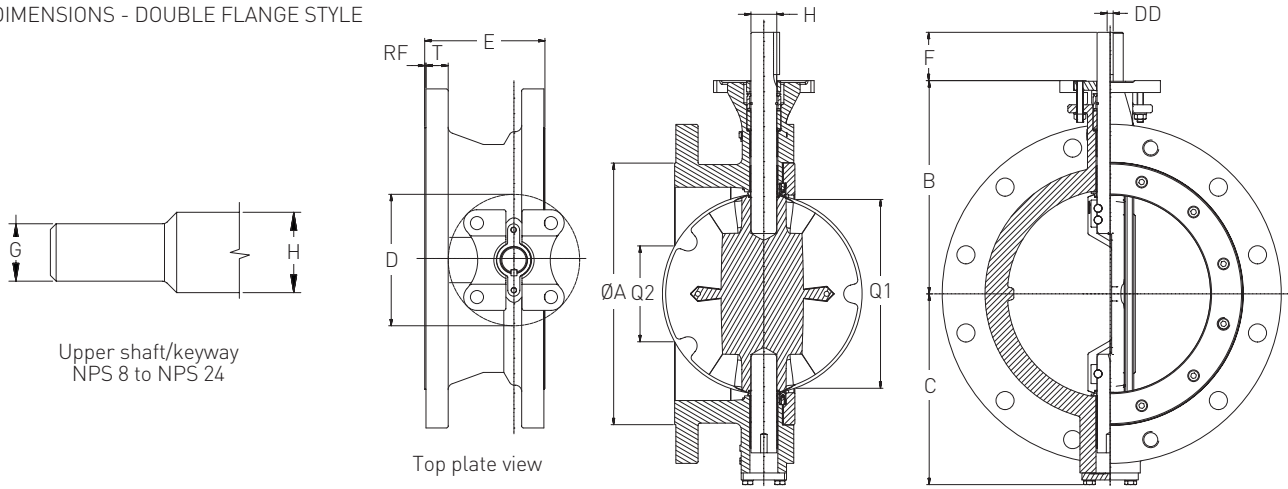

Upper shaft/keyway  
NPS 8 to NPS 24

Top plate view

### SERIES 36F, ASME CLASS 150, DOUBLE FLANGED STYLE, DIMENSIONS (inches)

Size NPS	A	B	C	D	E	F	G	H	Q1	Q2	T	RF
3	5.00	6 <sup>5</sup> / <sub>8</sub>	5 <sup>31</sup> / <sub>32</sub>	4.15	4.50	1 <sup>1</sup> / <sub>4</sub>	N/A	5 <sup>1</sup> / <sub>8</sub>	2.13	N/A	0.75	0.06
4	6.19	7 <sup>1</sup> / <sub>2</sub>	5 <sup>1</sup> / <sub>4</sub>	4.15	5.00	1 <sup>1</sup> / <sub>4</sub>	N/A	3 <sup>3</sup> / <sub>4</sub>	3.23	N/A	0.94	0.06
6	8.50	8 <sup>3</sup> / <sub>4</sub>	6 <sup>5</sup> / <sub>16</sub>	6.07	5.50	1 <sup>1</sup> / <sub>4</sub>	3 <sup>3</sup> / <sub>4</sub>	7 <sup>1</sup> / <sub>8</sub>	5.24	N/A	1.00	0.06
6*	8.50	8 <sup>3</sup> / <sub>4</sub>	6 <sup>5</sup> / <sub>16</sub>	6.07	5.50	1 <sup>1</sup> / <sub>4</sub>	N/A	7 <sup>1</sup> / <sub>8</sub>	5.24	N/A	1.00	0.06
8	10.62	10 <sup>1</sup> / <sub>8</sub>	8 <sup>9</sup> / <sub>16</sub>	6.07	6.00	2	N/A	1 <sup>1</sup> / <sub>8</sub>	7.06	N/A	1.12	0.06
10	12.75	11 <sup>3</sup> / <sub>8</sub>	9 <sup>9</sup> / <sub>8</sub>	6.07	6.50	2	1 <sup>1</sup> / <sub>8</sub>	1 <sup>3</sup> / <sub>8</sub>	9.13	79.00	1.18	0.06
10*	12.75	11 <sup>3</sup> / <sub>8</sub>	9 <sup>9</sup> / <sub>8</sub>	6.07	6.50	3	N/A	1 <sup>3</sup> / <sub>8</sub>	9.13	79.00	1.18	0.06
12	15.00	13	10 <sup>19</sup> / <sub>32</sub>	8.17	7.00	3	1 <sup>3</sup> / <sub>8</sub>	1 <sup>1</sup> / <sub>2</sub>	10.91	4.84	1.24	0.06
14	16.25	13 <sup>1</sup> / <sub>4</sub>	11 <sup>27</sup> / <sub>32</sub>	8.17	7.50	3	N/A	1 <sup>5</sup> / <sub>8</sub>	11.93	5.98	1.38	0.06
16	18.50	14 <sup>1</sup> / <sub>2</sub>	12 <sup>31</sup> / <sub>32</sub>	8.17	8.50	3	1 <sup>5</sup> / <sub>8</sub>	1 <sup>3</sup> / <sub>4</sub>	13.70	6.25	1.44	0.06
18	21.00	16	13 <sup>3</sup> / <sub>4</sub>	8.17	8.75	4 <sup>1</sup> / <sub>16</sub>	N/A	1 <sup>7</sup> / <sub>8</sub>	15.51	10.67	1.56	0.06
20	23.00	17 <sup>7</sup> / <sub>16</sub>	15 <sup>3</sup> / <sub>16</sub>	8.22	9.00	4 <sup>5</sup> / <sub>16</sub>	N/A	2 <sup>1</sup> / <sub>4</sub>	17.32	13.12	1.69	0.06
24	27.25	19 <sup>11</sup> / <sub>16</sub>	17 <sup>9</sup> / <sub>16</sub>	8.22	10.50	4 <sup>1</sup> / <sub>4</sub>	2 <sup>1</sup> / <sub>4</sub>	2 <sup>1</sup> / <sub>2</sub>	20.79	15.71	1.87	0.06

### SERIES 36F, ASME, CLASS 150, DOUBLE FLANGED STYLE, DIMENSIONS (inches [CONTINUED])

Size NPS	Top plate drilling					Flange drilling data				Mount- ing code
	DD or Keyway		No. PCD	Holes holes	Holes dia.	Number of bolts	Diameter of bolt holes	Diameter of bolt circle	Diameter of bolts (imperial)	
(inch)	(mm)									
3	7 <sup>1</sup> / <sub>16</sub>	11.11	3 <sup>1</sup> / <sub>4</sub>	4	7 <sup>1</sup> / <sub>16</sub>	4	3 <sup>3</sup> / <sub>4</sub>	6.00	5 <sup>1</sup> / <sub>8</sub> - 11UNC	BAC
4	1 <sup>1</sup> / <sub>2</sub>	12.70	3 <sup>1</sup> / <sub>4</sub>	4	7 <sup>1</sup> / <sub>16</sub>	8	3 <sup>3</sup> / <sub>4</sub>	7.50	5 <sup>1</sup> / <sub>8</sub> - 11UNC	BAD
6	1 <sup>1</sup> / <sub>2</sub>	12.70	5	4	9 <sup>1</sup> / <sub>16</sub>	8	7 <sup>1</sup> / <sub>8</sub>	9.50	3 <sup>3</sup> / <sub>4</sub> - 10UNC	CAD
6*	9 <sup>1</sup> / <sub>8</sub>	15.88	5	4	9 <sup>1</sup> / <sub>16</sub>	8	7 <sup>1</sup> / <sub>8</sub>	9.50	3 <sup>3</sup> / <sub>4</sub> - 10UNC	CAE
8	1 <sup>1</sup> / <sub>4</sub> x 1 <sup>1</sup> / <sub>4</sub> x 1 <sup>1</sup> / <sub>8</sub>	6.35 x 6.35 x 41	5	4	9 <sup>1</sup> / <sub>16</sub>	8	7 <sup>1</sup> / <sub>8</sub>	11.75	3 <sup>3</sup> / <sub>4</sub> - 10UNC	CAF
10	1 <sup>1</sup> / <sub>4</sub> x 1 <sup>1</sup> / <sub>4</sub> x 1 <sup>1</sup> / <sub>8</sub>	6.35 x 6.35 x 41	5	4	9 <sup>1</sup> / <sub>16</sub>	12	1	14.25	7 <sup>1</sup> / <sub>8</sub> - 9UNC	CAF
10*	5 <sup>1</sup> / <sub>16</sub> x 5 <sup>1</sup> / <sub>16</sub> x 2 <sup>5</sup> / <sub>8</sub>	7.94 x 7.94 x 67	5	4	9 <sup>1</sup> / <sub>16</sub>	12	1	14.25	7 <sup>1</sup> / <sub>8</sub> - 9UNC	CAG
12	5 <sup>1</sup> / <sub>16</sub> x 5 <sup>1</sup> / <sub>16</sub> x 2 <sup>5</sup> / <sub>8</sub>	7.94 x 7.94 x 67	6 <sup>1</sup> / <sub>2</sub>	4	13 <sup>1</sup> / <sub>16</sub>	12	1	17.00	7 <sup>1</sup> / <sub>8</sub> - 9UNC	DAG
14	3 <sup>3</sup> / <sub>8</sub> x 3 <sup>3</sup> / <sub>8</sub> x 2 <sup>5</sup> / <sub>8</sub>	9.53 x 9.53 x 67	6 <sup>1</sup> / <sub>2</sub>	4	13 <sup>1</sup> / <sub>16</sub>	12	1 <sup>1</sup> / <sub>8</sub>	18.75	1 - 8UNC	DAH
16	3 <sup>3</sup> / <sub>8</sub> x 3 <sup>3</sup> / <sub>8</sub> x 2 <sup>5</sup> / <sub>8</sub>	9.53 x 9.53 x 67	6 <sup>1</sup> / <sub>2</sub>	4	13 <sup>1</sup> / <sub>16</sub>	16	1 <sup>1</sup> / <sub>8</sub>	21.25	1 - 8UNC	DAH
18	1 <sup>1</sup> / <sub>2</sub> x 3 <sup>3</sup> / <sub>8</sub> x 4 <sup>1</sup> / <sub>8</sub>	12.70 x 9.53 x 105	6 <sup>1</sup> / <sub>2</sub>	4	13 <sup>1</sup> / <sub>16</sub>	16	1 <sup>1</sup> / <sub>4</sub>	22.75	1 <sup>1</sup> / <sub>8</sub> - 8UN	DAJ
20	1 <sup>1</sup> / <sub>2</sub> x 3 <sup>3</sup> / <sub>8</sub> x 4	12.70 x 9.53 x 102	6 <sup>1</sup> / <sub>2</sub>	4	13 <sup>1</sup> / <sub>16</sub>	20	1 <sup>1</sup> / <sub>4</sub>	25.00	1 <sup>1</sup> / <sub>8</sub> - 8UN	DAK
24	1 <sup>1</sup> / <sub>2</sub> x 3 <sup>3</sup> / <sub>8</sub> x 4	12.70 x 9.53 x 102	6 <sup>1</sup> / <sub>2</sub>	4	13 <sup>1</sup> / <sub>16</sub>	20	1 <sup>3</sup> / <sub>8</sub>	29.50	1 <sup>1</sup> / <sub>4</sub> - 8UN	DAK

\* E.N.P. discs require larger upper shaft connection diameters on NPS 6 and NPS 10 valve sizes for UHMWPE seat trims.

N/A = not applicable

# KEYSTONE SERIES 36 AND 37 K-LOK HIGH PERFORMANCE BUTTERFLY VALVES

## IMPERIAL DATA

### DIMENSIONS - DOUBLE FLANGE STYLE

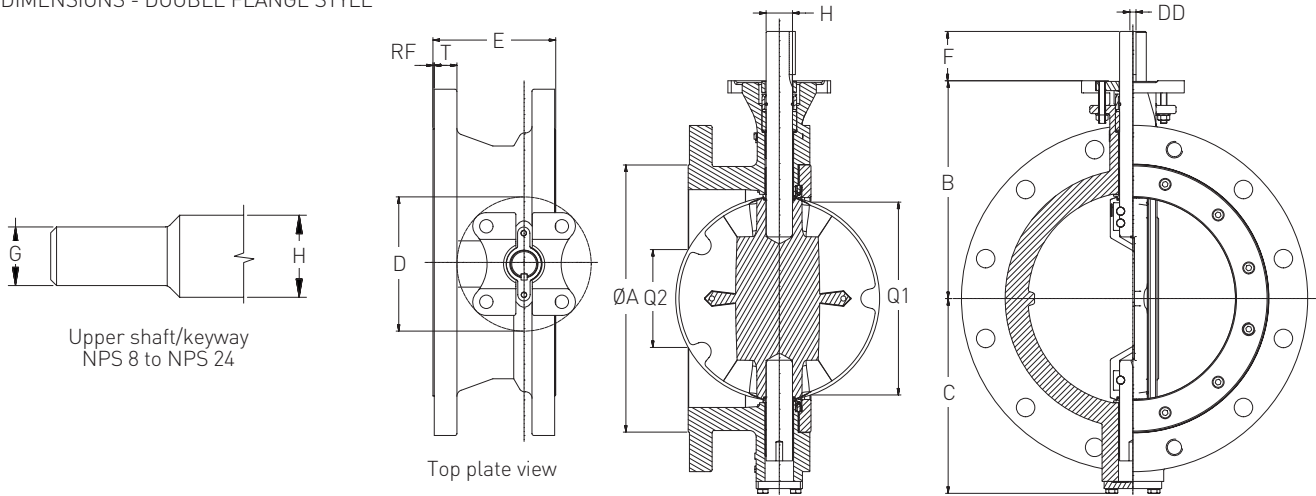

Upper shaft/keyway  
NPS 8 to NPS 24

Top plate view

### SERIES 37F, ASME, CLASS 300, DOUBLE FLANGED STYLE, DIMENSIONS (inches)

Size NPS	A	B	C	D	E	F	G	H	Q1	Q2	T	RF
3	5.00	6 <sup>5</sup> / <sub>8</sub>	4 <sup>21</sup> / <sub>32</sub>	4.15	4.50	1 <sup>1</sup> / <sub>4</sub>	N/A	<sup>5</sup> / <sub>8</sub>	2.13	N/A	1.12	0.06
4	6.19	7 <sup>1</sup> / <sub>2</sub>	5 <sup>1</sup> / <sub>4</sub>	4.15	5.00	1 <sup>1</sup> / <sub>4</sub>	N/A	<sup>3</sup> / <sub>4</sub>	3.15	N/A	1.24	0.06
6	8.50	8 <sup>3</sup> / <sub>4</sub>	6 <sup>7</sup> / <sub>8</sub>	6.07	5.50	1 <sup>1</sup> / <sub>4</sub>	N/A	<sup>7</sup> / <sub>8</sub>	5.20	N/A	1.44	0.06
8	10.62	10 <sup>1</sup> / <sub>8</sub>	8 <sup>5</sup> / <sub>16</sub>	6.07	6.00	2	N/A	1 <sup>1</sup> / <sub>8</sub>	6.69	N/A	1.61	0.06
10	12.75	11 <sup>3</sup> / <sub>8</sub>	9 <sup>5</sup> / <sub>8</sub>	6.07	6.50	3	N/A	1 <sup>3</sup> / <sub>8</sub>	8.78	3.11	1.87	0.06
12	15.00	13	11 <sup>3</sup> / <sub>32</sub>	8.17	7.00	3	1 <sup>3</sup> / <sub>8</sub>	1 <sup>1</sup> / <sub>2</sub>	10.59	6.36	2.01	0.06
14	16.25	14 <sup>3</sup> / <sub>8</sub>	12 <sup>21</sup> / <sub>32</sub>	8.17	7.50	4 <sup>1</sup> / <sub>4</sub>	N/A	1 <sup>7</sup> / <sub>8</sub>	11.81	7.24	2.13	0.06
16	18.50	16 <sup>1</sup> / <sub>16</sub>	13 <sup>27</sup> / <sub>32</sub>	8.17	8.50	4 <sup>1</sup> / <sub>8</sub>	N/A	2 <sup>1</sup> / <sub>4</sub>	13.58	8.29	2.24	0.06
18	21.00	17	15 <sup>1</sup> / <sub>32</sub>	8.17	8.75	4 <sup>7</sup> / <sub>32</sub>	N/A	2 <sup>1</sup> / <sub>2</sub>	15.43	11.50	2.38	0.06
20	23.00	20 <sup>3</sup> / <sub>16</sub>	16 <sup>11</sup> / <sub>32</sub>	7.50	9.00	6 <sup>1</sup> / <sub>2</sub>	N/A	2 <sup>3</sup> / <sub>4</sub>	17.20	13.85	2.50	0.06
24	27.25	23 <sup>3</sup> / <sub>8</sub>	19 <sup>3</sup> / <sub>32</sub>	9.50	10.50	6 <sup>13</sup> / <sub>16</sub>	N/A	3 <sup>1</sup> / <sub>2</sub>	20.67	16.62	2.76	0.06

### SERIES 37F, ASME, CLASS 300, DOUBLE FLANGED STYLE, DIMENSIONS (inches [CONTINUED])

Size NPS	Top plate drilling					Flange drilling data				Mounting code
	DD or Keyway (inch) (mm)		PCD	No. holes	Holes dia.	Number of bolts	Diameter of bolt holes	Diameter of bolt circle	Diameter of bolts (imperial)	
3	<sup>7</sup> / <sub>16</sub>	11.11	3 <sup>1</sup> / <sub>4</sub>	4	<sup>7</sup> / <sub>16</sub>	8	<sup>7</sup> / <sub>8</sub>	6.63	<sup>3</sup> / <sub>4</sub> - 10UNC	BAC
4	<sup>1</sup> / <sub>2</sub>	12.70	3 <sup>1</sup> / <sub>4</sub>	4	<sup>7</sup> / <sub>16</sub>	8	<sup>7</sup> / <sub>8</sub>	7.88	<sup>3</sup> / <sub>4</sub> - 10UNC	BAD
6	<sup>5</sup> / <sub>8</sub>	15.88	5	4	<sup>9</sup> / <sub>16</sub>	12	<sup>7</sup> / <sub>8</sub>	10.63	<sup>3</sup> / <sub>4</sub> - 10UNC	CAE
8	1 <sup>1</sup> / <sub>4</sub> x 1 <sup>1</sup> / <sub>4</sub> x 1 <sup>5</sup> / <sub>8</sub>	6.35 x 6.35 x 41	5	4	<sup>9</sup> / <sub>16</sub>	12	1	13.00	<sup>7</sup> / <sub>8</sub> - 9UNC	CAF
10	<sup>5</sup> / <sub>16</sub> x <sup>5</sup> / <sub>16</sub> x 2 <sup>5</sup> / <sub>8</sub>	7.94 x 7.94 x 67	5	4	<sup>9</sup> / <sub>16</sub>	16	1 <sup>1</sup> / <sub>8</sub>	15.25	1 - 8UNC	CAG
12	<sup>5</sup> / <sub>16</sub> x <sup>5</sup> / <sub>16</sub> x 2 <sup>5</sup> / <sub>8</sub>	7.94 x 7.94 x 67	6 <sup>1</sup> / <sub>2</sub>	4	<sup>13</sup> / <sub>16</sub>	16	1 <sup>1</sup> / <sub>4</sub>	17.75	1 <sup>1</sup> / <sub>8</sub> - 8UN	DAG
14	<sup>1</sup> / <sub>2</sub> x <sup>3</sup> / <sub>8</sub> x 4 <sup>1</sup> / <sub>8</sub>	12.70 x 9.53 x 105	6 <sup>1</sup> / <sub>2</sub>	4	<sup>13</sup> / <sub>16</sub>	20	1 <sup>1</sup> / <sub>4</sub>	20.25	1 <sup>1</sup> / <sub>8</sub> - 8UN	DAJ
16	<sup>1</sup> / <sub>2</sub> x <sup>3</sup> / <sub>8</sub> x 4	12.70 x 9.53 x 102	6 <sup>1</sup> / <sub>2</sub>	4	<sup>13</sup> / <sub>16</sub>	20	1 <sup>3</sup> / <sub>8</sub>	22.50	1 <sup>1</sup> / <sub>4</sub> - 8UN	DAK
18	<sup>5</sup> / <sub>8</sub> x <sup>5</sup> / <sub>8</sub> x 4	15.88 x 15.88 x 102	6 <sup>1</sup> / <sub>2</sub>	4	<sup>13</sup> / <sub>16</sub>	24	1 <sup>3</sup> / <sub>8</sub>	24.75	1 <sup>1</sup> / <sub>4</sub> - 8UN	DBA
20	<sup>5</sup> / <sub>8</sub> x <sup>5</sup> / <sub>8</sub> x 6 <sup>3</sup> / <sub>8</sub>	15.88 x 15.88 x 162	8	4	<sup>13</sup> / <sub>16</sub>	24	1 <sup>3</sup> / <sub>8</sub>	27.00	1 <sup>1</sup> / <sub>4</sub> - 8UN	LAX
24	<sup>7</sup> / <sub>8</sub> x <sup>7</sup> / <sub>8</sub> x 5 <sup>11</sup> / <sub>16</sub>	22.23 x 22.23 x 144	9 <sup>3</sup> / <sub>4</sub>	4	1 <sup>1</sup> / <sub>16</sub>	24	1 <sup>5</sup> / <sub>8</sub>	32.00	1 <sup>1</sup> / <sub>2</sub> - 8UN	MAY

N/A = not applicable

# KEYSTONE SERIES 36 AND 37 K-LOK HIGH PERFORMANCE BUTTERFLY VALVES

## RECOMMENDED FLANGE BOLT LENGTHS

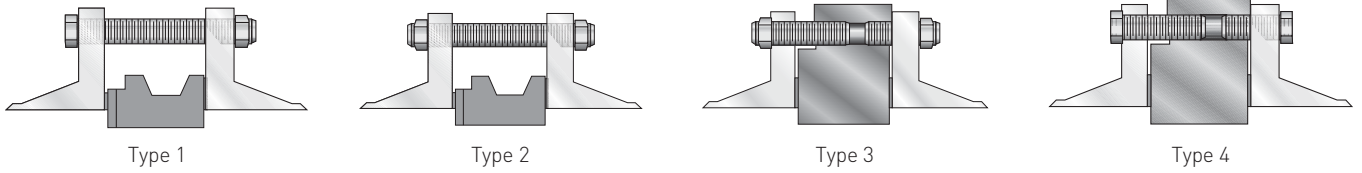

## SERIES 36 ASME CLASS 150 (mm)

### WAFER STYLE

Size DN	NPS	Qty	Type 1 (flange bolt) (HEX head)		Type 2 (threaded rod) (all thread)	
			Qty		Qty	
50	2	4	5/8 - 11UNC x 127	4	5/8 - 11UNC x 146	
65	2½	4	5/8 - 11UNC x 117	4	5/8 - 11UNC x 143	
80	3	4	5/8 - 11UNC x 127	4	5/8 - 11UNC x 143	
100	4	8	5/8 - 11UNC x 127	8	5/8 - 11UNC x 149	
125	5	8	¾ - 10UNC x 133	8	¾ - 10UNC x 159	
150	6	8	¾ - 10UNC x 137	8	¾ - 10UNC x 162	
200	8	8	¾ - 10UNC x 149	8	¾ - 10UNC x 175	
250	10	12	7/8 - 9UNC x 165	12	7/8 - 9UNC x 194	
300	12	12	7/8 - 9UNC x 178	12	7/8 - 9UNC x 203	
350	14	12	1 - 8UNC x 197	12	1 - 8UNC x 229	
400	16	16	1 - 8UNC x 216	16	1 - 8UNC x 244	
450	18	16	1½ - 8UN x 241	16	1½ - 8UN x 270	
500	20	16	1½ - 8UN x 254	16	1½ - 8UN x 289	
		4	1½ - 8UN x 89	8	1½ - 8UN x 124	
600	24	4	1½ - 8UN x 83			
		16	1¼ - 8UN x 292	16	1¼ - 8UN x 330	
		8	1¼ - 8UN x 121	8	1¼ - 8UN x 162	

### LUG STYLE

Size DN	NPS	Qty	Type 3 (threaded studs) (full thread)		Type 4 (flange bolt) (HEX head)	
			Qty		Qty	
50	2	8	5/8 - 11UNC x 73	8	5/8 - 11UNC x 51	
65	2½	8	5/8 - 11UNC x 67	8	5/8 - 11UNC x 44	
80	3	8	5/8 - 11UNC x 67	8	5/8 - 11UNC x 44	
100	4	16	5/8 - 11UNC x 70	16	5/8 - 11UNC x 51	
125	5	16	¾ - 10UNC x 76	16	¾ - 10UNC x 51	
150	6	8	¾ - 10UNC x 76	8	¾ - 10UNC x 51	
		8	¾ - 10UNC x 83	8	¾ - 10UNC x 57	
200	8	16	¾ - 10UNC x 86	16	¾ - 10UNC x 57	
250	10	24	7/8 - 9UNC x 92	24	7/8 - 9UNC x 64	
300	12	24	7/8 - 9UNC x 98	24	7/8 - 9UNC x 70	
350	14	24	1 - 8UNC x 114	24	1 - 8UNC x 83	
400	16	32	1 - 8UNC x 121	32	1 - 8UNC x 89	
450	18	32	1½ - 8UN x 133	32	1½ - 8UN x 95	
500	20	32	1½ - 8UN x 140	4	1½ - 8UN x 89 (FF)	
		8	1½ - 8UN x 124	4	1½ - 8UN x 83 (BF)	
600	24			32	1½ - 8UN x 102	
		40	1¼ - 8UN x 162	40	1¼ - 8UN x 121	

## SERIES 37 ASME CLASS 300 (mm)

### WAFER STYLE

Size DN	NPS	Qty	Type 1 (flange bolt) (HEX head)		Type 2 (threaded rod) (all thread)	
			Qty		Qty	
50	2	8	5/8 - UNC x 133	8	5/8 - 11UNC x 159	
65	2½	8	¾ - 10UNC x 127	8	¾ - 10UNC x 152	
80	3	8	¾ - 10UNC x 133	8	¾ - 10UNC x 159	
100	4	8	¾ - 11UNC x 146	8	¾ - 11UNC x 171	
125	5	8	¾ - 11UNC x 159	8	¾ - 11UNC x 184	
150	6	12	¾ - 11UNC x 162	12	¾ - 11UNC x 187	
200	8	12	7/8 - 10UNC x 191	12	7/8 - 10UNC x 216	
250	10	12	1 - 8UNC x 216	12	1 - 8UNC x 241	
		8	1 - 8UNC x 76	8	1 - 8UNC x 121	
300	12	16	1½ - 8UN x 235	16	1½ - 8UN x 267	
350	14	16	1½ - 8UN x 267	16	1½ - 8UN x 298	
		8	1½ - 8UN x 83	8	1½ - 8UN x 117	
400	16	16	1¼ - 8UN x 292	16	1¼ - 8UN x 321	
		8	1¼ - 8UN x 89	8	1¼ - 8UN x 127	
		8	1¼ - 8UN x 89	8	1¼ - 8UN x 127	
450	18	20	1¼ - 8UN x 311	20	1¼ - 8UN x 349	
		8	1¼ - 8UN x 95	8	1¼ - 8UN x 133	
500	20	20	1¼ - 8UN x 327	20	1¼ - 8UN x 364	
		8	1¼ - 8UN x 102	8	1¼ - 8UN x 140	
600	24	20	1½ - 8UN x 368	20	1½ - 8UN x 413	
		8	1½ - 8UN x 114	8	1½ - 8UN x 159	

### LUG STYLE

Size DN	NPS	Qty	Type 3 (threaded studs) (all thread)		Type 4 (flange bolt) (HEX head)	
			Qty		Qty	
50	2	16	5/8 - 11UNC x 73	16	5/8 - 11UNC x 51	
65	2½	16	¾ - 10UNC x 76	16	¾ - 10UNC x 51	
80	3	16	¾ - 10UNC x 76	16	¾ - 10UNC x 51	
100	4	16	¾ - 10UNC x 83	16	¾ - 10UNC x 57	
125	5	16	¾ - 10UNC x 89	16	¾ - 10UNC x 64	
150	6	24	¾ - 10UNC x 92	24	¾ - 10UNC x 64	
200	8	24	7/8 - 9UNC x 105	24	7/8 - 9UNC x 76	
250	10	32	1 - 8UNC x 121	32	1 - 8UNC x 89	
300	12	32	1½ - 8UN x 130	32	1½ - 8UN x 95	
350	14	32	1½ - 8UN x 146	32	1½ - 8UN x 108	
		8	1½ - 8UN x 117	8	1½ - 8UN x 83	
400	16	32	1¼ - 8UN x 159	32	1¼ - 8UN x 111	
		8	1¼ - 8UN x 127	8	1¼ - 8UN x 89	
450	18	40	1¼ - 8UN x 171	40	1¼ - 8UN x 133	
		8	1¼ - 8UN x 133	8	1¼ - 8UN x 95	
500	20	40	1¼ - 8UN x 181	40	1¼ - 8UN x 140	
		8	1¼ - 8UN x 140	8	1¼ - 8UN x 102	
600	24	40	1½ - 8UN x 203	40	1½ - 8UN x 159	
		8	1½ - 8UN x 159	8	1½ - 8UN x 114	

# KEYSTONE SERIES 36 AND 37 K-LOK HIGH PERFORMANCE BUTTERFLY VALVES

## RECOMMENDED FLANGE BOLT LENGTHS

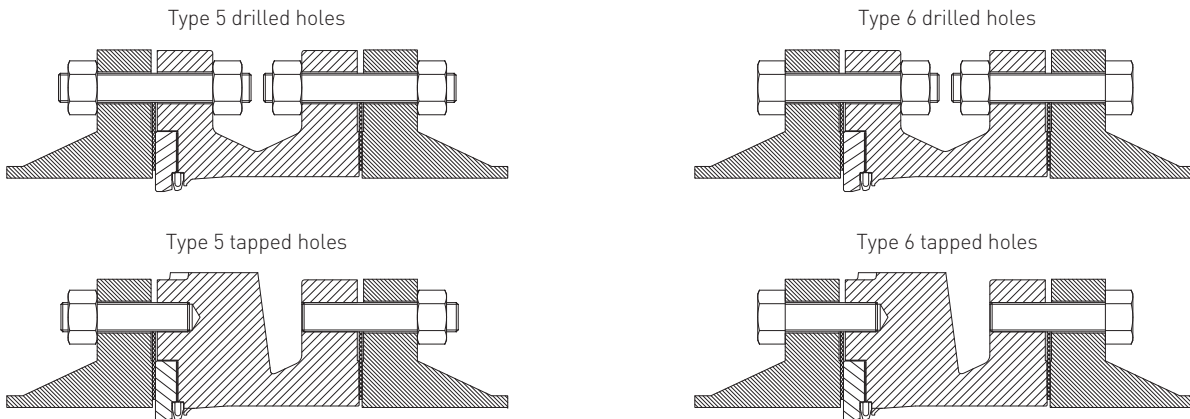

## SERIES 36 ASME CLASS 150 (mm)

### DOUBLE FLANGED STYLE

Size	Type 5 (full threaded rod)				
	Drilled holes		Tapped holes		
DN	NPS	Qty	Stud sizes	Qty	Stud sizes
80	3	4	5/8 - 11UNC - 89	4	5/8 - 11UNC - 70
100	4	8	5/8 - 11UNC - 95	8	5/8 - 11UNC - 76
150	6	8	3/4 - 10UNC - 105	8	3/4 - 10UNC - 83
200	8	12	3/4 - 10UNC - 111	4	3/4 - 10UNC - 89
250	10	20	7/8 - 9UNC - 121	4	7/8 - 9UNC - 95
300	12	20	7/8 - 9UNC - 124	4	7/8 - 9UNC - 89
350	14	20	1 - 8UNC - 140	4	1 - 8UNC - 98
400	16	28	1 - 8UNC - 143	4	1 - 8UNC - 105
450	18	28	1 1/8 - 8UN - 156	4	1 1/8 - 8UN - 121
500	20	36	1 1/8 - 8UN - 162	4	1 1/8 - 8UN - 114
600	24	36	1 1/4 - 8UN - 178	4	1 1/4 - 8UN - 124

### DOUBLE FLANGED STYLE

Size	Type 6 (hex head)				
	Drilled holes		Tapped holes		
DN	NPS	Qty	Bolt sizes	Qty	Bolt sizes
80	3	4	5/8 - 11UNC - 70	4	5/8 - 11UNC - 48
100	4	8	5/8 - 11UNC - 76	8	5/8 - 11UNC - 54
150	6	8	3/4 - 10UNC - 83	8	3/4 - 10UNC - 57
200	8	12	3/4 - 10UNC - 89	4	3/4 - 10UNC - 64
250	10	20	7/8 - 9UNC - 95	4	7/8 - 9UNC - 67
300	12	20	7/8 - 9UNC - 98	4	7/8 - 9UNC - 60
350	14	20	1 - 8UNC - 108	4	1 - 8UNC - 67
400	16	28	1 - 8UNC - 111	4	1 - 8UNC - 73
450	18	28	1 1/8 - 8UN - 121	4	1 1/8 - 8UN - 86
500	20	36	1 1/8 - 8UN - 127	4	1 1/8 - 8UN - 79
600	24	36	1 1/4 - 8UN - 140	4	1 1/4 - 8UN - 86

## SERIES 37 ASME CLASS 300 (mm)

### DOUBLE FLANGED STYLE

Size	Type 5 (full threaded rod)				
	Drilled holes		Tapped holes		
DN	NPS	Qty	Bolt sizes	Qty	Bolt sizes
80	3	8	3/4 - 10UNC - 111	8	3/4 - 10UNC - 89
100	4	8	3/4 - 10UNC - 117	8	3/4 - 10UNC - 95
150	6	20	3/4 - 10UNC - 127	4	3/4 - 10UNC - 105
200	8	20	7/8 - 9UNC - 143	4	7/8 - 9UNC - 114
250	10	24	1 - 8UNC - 162	8	1 - 8UNC - 111
300	12	24	1 1/8 - 8UN - 175	8	1 1/8 - 8UN - 121
350	14	32	1 1/8 - 8UN - 184	8	1 1/8 - 8UN - 127
400	16	32	1 1/4 - 8UN - 197	8	1 1/4 - 8UN - 137
450	18	40	1 1/4 - 8UN - 203	8	1 1/4 - 8UN - 140
500	20	40	1 1/4 - 8UN - 210	8	1 1/4 - 8UN - 140
600	24	40	1 1/2 - 8UN - 235	8	1 1/2 - 8UN - 159

### DOUBLE FLANGED STYLE

Size	Type 6 (hex head)				
	Drilled holes		Tapped holes		
DN	NPS	Qty	Bolt sizes	Qty	Bolt sizes
80	3	8	3/4 - 10UNC - 86	8	3/4 - 10UNC - 64
100	4	8	3/4 - 10UNC - 92	8	3/4 - 10UNC - 70
150	6	20	3/4 - 10UNC - 102	4	3/4 - 10UNC - 79
200	8	20	7/8 - 9UNC - 114	4	7/8 - 9UNC - 86
250	10	24	1 - 8UNC - 130	8	1 - 8UNC - 79
300	12	24	1 1/8 - 8UN - 140	8	1 1/8 - 8UN - 86
350	14	32	1 1/8 - 8UN - 149	8	1 1/8 - 8UN - 89
400	16	32	1 1/4 - 8UN - 159	8	1 1/4 - 8UN - 98
450	18	40	1 1/4 - 8UN - 165	8	1 1/4 - 8UN - 102
500	20	40	1 1/4 - 8UN - 171	8	1 1/4 - 8UN - 102
600	24	40	1 1/2 - 8UN - 191	8	1 1/2 - 8UN - 114



# KEYSTONE SERIES 36 AND 37 K-LOK HIGH PERFORMANCE BUTTERFLY VALVES

## RECOMMENDED FLANGE BOLT LENGTHS

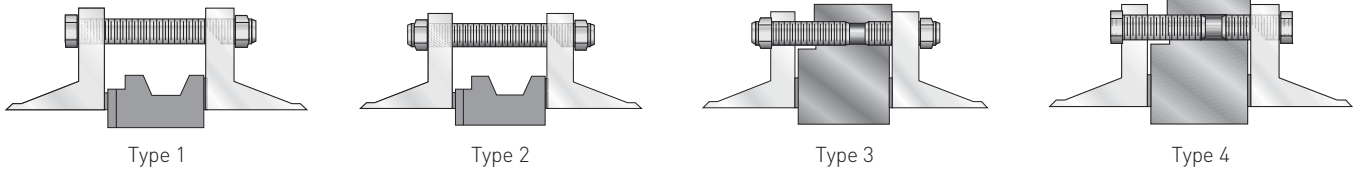

### SERIES 36 ASME CLASS 150 (inches)

#### WAFER STYLE

Size DN	NPS	Qty	Type 1 (flange bolt) (HEX head)		Type 2 (threaded rod) (all thread)	
			Qty		Qty	
50	2	4	5/8 - 11UNC x 5	4	5/8 - 11UNC x 5 3/4	
65	2 1/2	4	5/8 - 11UNC x 4 5/8	4	5/8 - 11UNC x 5 5/8	
80	3	4	5/8 - 11UNC x 5	4	5/8 - 11UNC x 5 5/8	
100	4	8	5/8 - 11UNC x 5	8	5/8 - 11UNC x 5 7/8	
125	5	8	3/4 - 10UNC x 5 1/4	8	3/4 - 10UNC x 6 1/4	
150	6	8	3/4 - 10UNC x 5 3/8	8	3/4 - 10UNC x 6 3/8	
200	8	8	3/4 - 10UNC x 5 7/8	8	3/4 - 10UNC x 6 7/8	
250	10	12	7/8 - 9UNC x 6 1/2	12	7/8 - 9UNC x 7 5/8	
300	12	12	7/8 - 9UNC x 7	12	7/8 - 9UNC x 8	
350	14	12	1 - 8UNC x 7 3/4	12	1 - 8UNC x 9	
400	16	16	1 - 8UNC x 8 1/2	16	1 - 8UNC x 9 5/8	
450	18	16	1 1/8 - 8UN x 9 1/2	16	1 1/8 - 8UN x 10 5/8	
500	20	16	1 1/8 - 8UN x 10	16	1 1/8 - 8UN x 11 3/8	
		4	1 1/8 - 8UN x 3 1/2	8	1 1/8 - 8UN x 4 7/8	
		4	1 1/8 - 8UN x 3 3/4			
600	24	16	1 1/4 - 8UN x 11 1/2	16	1 1/4 - 8UN x 13	
		8	1 1/4 - 8UN x 4 3/4	8	1 1/4 - 8UN x 6 3/8	

#### LUG STYLE

Size DN	NPS	Qty	Type 3 (threaded studs) (full thread)		Type 4 (flange bolt) (HEX head)	
			Qty		Qty	
50	2	8	5/8 - 11UNC x 2 7/8	8	5/8 - 11UNC x 2	
65	2 1/2	8	5/8 - 11UNC x 2 5/8	8	5/8 - 11UNC x 1 3/4	
80	3	8	5/8 - 11UNC x 2 5/8	8	5/8 - 11UNC x 1 3/4	
100	4	16	5/8 - 11UNC x 2 3/4	16	5/8 - 11UNC x 2	
125	5	16	3/4 - 10UNC x 3	16	3/4 - 10UNC x 2	
150	6	8	3/4 - 10UNC x 3	8	3/4 - 10UNC x 2	
		8	3/4 - 10UNC x 3 1/4	8	3/4 - 10UNC x 2 1/4	
200	8	16	3/4 - 10UNC x 3 3/8	16	3/4 - 10UNC x 2 1/4	
250	10	24	7/8 - 9UNC x 3 3/8	24	7/8 - 9UNC x 2 1/2	
300	12	24	7/8 - 9UNC x 3 1/8	24	7/8 - 9UNC x 2 3/4	
350	14	24	1 - 8UNC x 4 1/2	24	1 - 8UNC x 3 1/4	
400	16	32	1 - 8UNC x 4 3/4	32	1 - 8UNC x 3 1/2	
450	18	32	1 1/8 - 8UN x 5 1/4	32	1 1/8 - 8UN x 3 3/4	
500	20	32	1 1/8 - 8UN x 5 1/2	4	1 1/8 - 8UN x 3 1/2 (FF)	
		8	1 1/8 - 8UN x 4 7/8	4	1 1/8 - 8UN x 3 1/4 (BF)	
				32	1 1/8 - 8UN x 4	
600	24	40	1 1/4 - 8UN x 6 3/8	40	1 1/4 - 8UN x 4 3/4	

### SERIES 37 ASME CLASS 300 (inches)

#### WAFER STYLE

Size DN	NPS	Qty	Type 1 (flange bolt) (HEX head)		Type 2 (threaded rod) (all thread)	
			Qty		Qty	
50	2	8	5/8 - UNC x 5 1/4	8	5/8 - 11UNC x 6 1/4	
65	2 1/2	8	3/4 - 10UNC x 5	8	3/4 - 10UNC x 6	
80	3	8	3/4 - 10UNC x 5 1/4	8	3/4 - 10UNC x 6 1/4	
100	4	8	3/4 - 11UNC x 5 3/4	8	3/4 - 11UNC x 6 3/4	
125	5	8	3/4 - 11UNC x 6 1/4	8	3/4 - 11UNC x 7 1/4	
150	6	12	3/4 - 11UNC x 6 3/8	12	3/4 - 11UNC x 7 3/8	
200	8	12	7/8 - 10UNC x 7 1/2	12	7/8 - 10UNC x 8 1/2	
250	10	12	1 - 8UNC x 8 1/2	12	1 - 8UNC x 9 1/2	
		8	1 - 8UNC x 3	8	1 - 8UNC x 4 3/4	
300	12	16	1 1/8 - 8UN x 9 1/4	16	1 1/8 - 8UN x 10 1/2	
350	14	16	1 1/8 - 8UN x 10 1/2	16	1 1/8 - 8UN x 11 3/4	
		8	1 1/8 - 8UN x 3 3/4	8	1 1/8 - 8UN x 4 5/8	
400	16	16	1 1/4 - 8UN x 11 1/2	16	1 1/4 - 8UN x 12 5/8	
		8	1 1/4 - 8UN x 3 1/2	8	1 1/4 - 8UN x 5	
450	18	20	1 1/4 - 8UN x 12 1/4	20	1 1/4 - 8UN x 13 3/4	
		8	1 1/4 - 8UN x 3 3/4	8	1 1/4 - 8UN x 5 1/4	
500	20	20	1 1/4 - 8UN x 12 7/8	20	1 1/4 - 8UN x 14 3/8	
		8	1 1/4 - 8UN x 4	8	1 1/4 - 8UN x 5 1/2	
600	24	20	1 1/2 - 8UN x 14 1/2	20	1 1/2 - 8UN x 16 1/4	
		8	1 1/2 - 8UN x 4 1/2	8	1 1/2 - 8UN x 6 1/4	

#### LUG STYLE

Size DN	NPS	Qty	Type 3 (threaded studs) (all thread)		Type 4 (flange bolt) (HEX head)	
			Qty		Qty	
50	2	16	5/8 - 11UNC x 2 7/8	16	5/8 - 11UNC x 2	
65	2 1/2	16	3/4 - 10UNC x 3	16	3/4 - 10UNC x 2	
80	3	16	3/4 - 10UNC x 3	16	3/4 - 10UNC x 2	
100	4	16	3/4 - 10UNC x 3 1/4	16	3/4 - 10UNC x 2 1/4	
125	5	16	3/4 - 10UNC x 3 1/2	16	3/4 - 10UNC x 2 1/2	
150	6	24	3/4 - 10UNC x 3 5/8	24	3/4 - 10UNC x 2 1/2	
200	8	24	7/8 - 9UNC x 4 1/8	24	7/8 - 9UNC x 3	
250	10	32	1 - 8UNC x 4 3/4	32	1 - 8UNC x 3 1/2	
300	12	32	1 1/8 - 8UN x 5 1/8	32	1 1/8 - 8UN x 3 3/4	
350	14	32	1 1/8 - 8UN x 5 3/4	32	1 1/8 - 8UN x 4 1/4	
		8	1 1/8 - 8UN x 4 5/8	8	1 1/8 - 8UN x 3 3/4	
400	16	32	1 1/4 - 8UN x 6 1/4	32	1 1/4 - 8UN x 4 3/8	
		8	1 1/4 - 8UN x 5	8	1 1/4 - 8UN x 3 1/2	
450	18	40	1 1/4 - 8UN x 6 3/4	40	1 1/4 - 8UN x 5 1/4	
		8	1 1/4 - 8UN x 5 1/4	8	1 1/4 - 8UN x 3 3/4	
500	20	40	1 1/4 - 8UN x 7 1/8	40	1 1/4 - 8UN x 5 1/2	
		8	1 1/4 - 8UN x 5 1/2	8	1 1/4 - 8UN x 4	
600	24	40	1 1/2 - 8UN x 8	40	1 1/2 - 8UN x 6 1/4	
		8	1 1/2 - 8UN x 6 1/4	8	1 1/2 - 8UN x 4 1/2	

# KEYSTONE SERIES 36 AND 37 K-LOK HIGH PERFORMANCE BUTTERFLY VALVES

## RECOMMENDED FLANGE BOLT LENGTHS

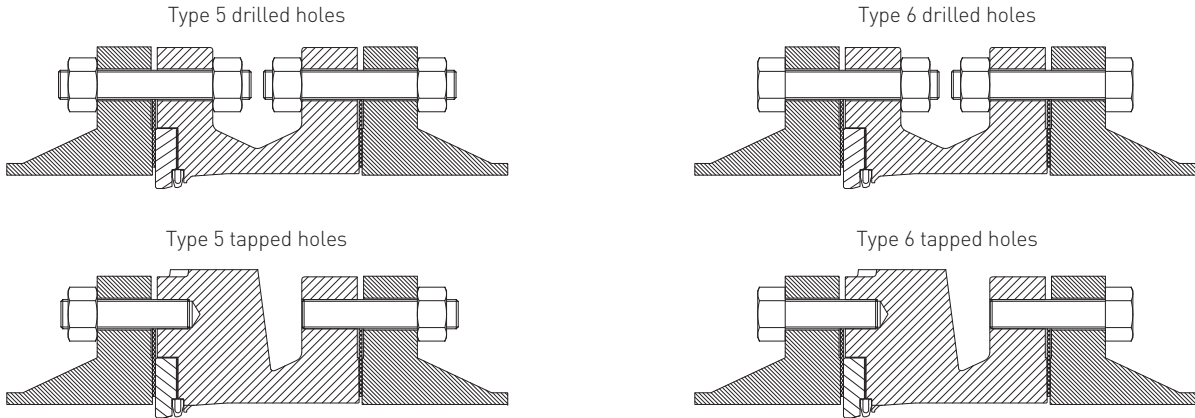

## SERIES 36 ASME CLASS 150 (inches)

### DOUBLE FLANGED STYLE

Size	Type 5 (full threaded rod)				
	DN	NPS	Drilled holes Qty	Tapped holes Qty	Stud sizes
80	3	4	5/8 - 11UNC - 3 1/2	4	5/8 - 11UNC - 2 3/4
100	4	8	5/8 - 11UNC - 3 3/4	8	5/8 - 11UNC - 3
150	6	8	3/4 - 10UNC - 4 1/2	8	3/4 - 10UNC - 3 1/4
200	8	12	3/4 - 10UNC - 4 3/8	4	3/4 - 10UNC - 3 1/2
250	10	20	7/8 - 9UNC - 4 3/4	4	7/8 - 9UNC - 3 3/4
300	12	20	7/8 - 9UNC - 4 7/8	4	7/8 - 9UNC - 3 1/2
350	14	20	1 - 8UNC - 5 1/2	4	1 - 8UNC - 3 7/8
400	16	28	1 - 8UNC - 5 5/8	4	1 - 8UNC - 4 1/8
450	18	28	1 1/8 - 8UN - 6 1/8	4	1 1/8 - 8UN - 4 3/4
500	20	36	1 1/8 - 8UN - 6 3/8	4	1 1/8 - 8UN - 4 1/2
600	24	36	1 1/4 - 8UN - 7	4	1 1/4 - 8UN - 4 7/8

### DOUBLE FLANGED STYLE

Size	Type 6 (hex head)				
	DN	NPS	Drilled holes Qty	Tapped holes Qty	Bolt sizes
80	3	4	5/8 - 11UNC - 2 3/4	4	5/8 - 11UNC - 1 7/8
100	4	8	5/8 - 11UNC - 3	8	5/8 - 11UNC - 2 1/8
150	6	8	3/4 - 10UNC - 3 1/4	8	3/4 - 10UNC - 2 1/4
200	8	12	3/4 - 10UNC - 3 1/2	4	3/4 - 10UNC - 2 1/2
250	10	20	7/8 - 9UNC - 3 3/4	4	7/8 - 9UNC - 2 5/8
300	12	20	7/8 - 9UNC - 3 7/8	4	7/8 - 9UNC - 2 3/8
350	14	20	1 - 8UNC - 4 1/4	4	1 - 8UNC - 2 5/8
400	16	28	1 - 8UNC - 4 3/8	4	1 - 8UNC - 2 7/8
450	18	28	1 1/8 - 8UN - 4 3/4	4	1 1/8 - 8UN - 3 3/8
500	20	36	1 1/8 - 8UN - 5	4	1 1/8 - 8UN - 3 3/8
600	24	36	1 1/4 - 8UN - 5 1/2	4	1 1/4 - 8UN - 3 3/8

## SERIES 37 ASME CLASS 300 (inches)

### DOUBLE FLANGED STYLE

Size	Type 5 (full threaded rod)				
	DN	NPS	Drilled holes Qty	Tapped holes Qty	Bolt sizes
80	3	8	3/4 - 10UNC - 4 3/8	8	3/4 - 10UNC - 3 1/2
100	4	8	3/4 - 10UNC - 4 5/8	8	3/4 - 10UNC - 3 3/4
150	6	20	3/4 - 10UNC - 5	4	3/4 - 10UNC - 4 1/8
200	8	20	7/8 - 9UNC - 5 5/8	4	7/8 - 9UNC - 4 1/2
250	10	24	1 - 8UNC - 6 3/8	8	1 - 8UNC - 4 3/8
300	12	24	1 1/8 - 8UN - 6 7/8	8	1 1/8 - 8UN - 4 3/4
350	14	32	1 1/8 - 8UN - 7 1/4	8	1 1/8 - 8UN - 5
400	16	32	1 1/4 - 8UN - 7 3/4	8	1 1/4 - 8UN - 5 3/8
450	18	40	1 1/4 - 8UN - 8	8	1 1/4 - 8UN - 5 1/2
500	20	40	1 1/4 - 8UN - 8 1/4	8	1 1/4 - 8UN - 5 1/2
600	24	40	1 1/2 - 8UN - 9 1/4	8	1 1/2 - 8UN - 6 1/4

### DOUBLE FLANGED STYLE

Size	Type 6 (hex head)				
	DN	NPS	Drilled holes Qty	Tapped holes Qty	Bolt sizes
80	3	8	3/4 - 10UNC - 3 3/8	8	3/4 - 10UNC - 2 1/2
100	4	8	3/4 - 10UNC - 3 5/8	8	3/4 - 10UNC - 2 3/4
150	6	20	3/4 - 10UNC - 4	4	3/4 - 10UNC - 3 1/8
200	8	20	7/8 - 9UNC - 4 1/2	4	7/8 - 9UNC - 3 3/8
250	10	24	1 - 8UNC - 5 1/8	8	1 - 8UNC - 3 3/8
300	12	24	1 1/8 - 8UN - 5 1/2	8	1 1/8 - 8UN - 3 3/8
350	14	32	1 1/8 - 8UN - 5 5/8	8	1 1/8 - 8UN - 3 1/2
400	16	32	1 1/4 - 8UN - 6 1/4	8	1 1/4 - 8UN - 3 3/8
450	18	40	1 1/4 - 8UN - 6 1/2	8	1 1/4 - 8UN - 4
500	20	40	1 1/4 - 8UN - 6 3/4	8	1 1/4 - 8UN - 4
600	24	40	1 1/2 - 8UN - 7 1/2	8	1 1/2 - 8UN - 4 1/2

# KEYSTONE SERIES 36 AND 37 K-LOK HIGH PERFORMANCE BUTTERFLY VALVES

## METRIC DATA

### EXTENSION BRACKETS FOR VARIOUS TEMPERATURES

Pipeline fluid temperature	Required extension lengths mm				
	Handle	Gear	Std. F89	High temp. F89	Standard F777
-73°C - 190°C	-	-	-	-	-
191°C - 238°C	100	-	-	-	100
239°C - 293°C	150	100	100	-	100
293°C - 343°C	150	100	100	-	100
343°C - 385°C	150	150	150	100	150
386°C - 440°C	200	200	200	150	200
441°C - 496°C	250	203	203	150	200
496°C - 538°C	250	250	250	200	250

### NOTES

- Surrounding air temperature is assumed to be 21°C. For every degree over 38°C of the surrounding air, deduct 2 degrees from the maximum temperature ranges shown under the Pipeline fluid temperature column. (Example: 52°C external temperature reduces maximum temperature values under the Pipeline fluid temperature column to 163, 210, 265, 315, etc.)
- Valves may be insulated or uninsulated.
- Brackets may be open rectangular tubes or the standard closed Keystone tubular shaft extensions.
- All actuators have a maximum service temperature (outside atmosphere). These temperature limitations apply regardless of K-LOK extension lengths.

### VACUUM RATING

The combination of interference fit seats and bi-directional packing makes the K-LOK especially well suited for vacuum service.

Standard K-LOK high performance valves are rated to an absolute pressure of  $1.016 \times 10^{-3}$  mm Hg. Higher vacuum applications are available.

### K<sub>v</sub> VALUES VS. TRAVEL POSITION

Size DN	Angle of opening								ASME 150 90°	ASME 300 90°
	10°	20°	30°	40°	50°	60°	70°	80°		
50	5	9	16	29	44	67	91	116	141	138
65	5	9	16	29	46	69	96	128	151	147
80	7	10	21	37	58	86	120	160	190	185
100	14	20	38	69	112	167	232	310	366	356
125	26	38	72	128	209	315	434	580	685	677
150	43	60	112	198	319	474	655	871	1030	983
200	72	101	216	377	599	907	1290	1725	2103	1983
250	124	174	391	650	1021	1570	2251	3052	3913	3735
300	179	262	584	906	1401	2384	3308	4590	5961	5689
350	222	310	644	1022	1646	2690	3807	5366	7155	6827
400	265	372	692	1226	1973	3115	4526	6491	8654	8258
450	322	472	966	1611	2577	4082	5800	8486	10741	10249
500	399	586	1198	1996	3457	5323	7581	10909	13301	12689
600	560	854	1790	3278	5224	7836	11465	15918	18671	17813

### NOTES

K<sub>v</sub> is the volume of water in m<sup>3</sup>/h that will pass through a valve with a pressure drop of 1 bar at 20°C.

# KEYSTONE SERIES 36 AND 37 K-LOK HIGH PERFORMANCE BUTTERFLY VALVES

## IMPERIAL DATA

### EXTENSION BRACKETS FOR VARIOUS TEMPERATURES

Pipeline fluid temperature	Required extension lengths inches				
	Handle	Gear	Std. F89	High temp. F89	Standard F777
-100°F - 375°F	-	-	-	-	-
376°F - 460°F	4	-	-	-	4
461°F - 560°F	6	4	4	-	4
561°F - 650°F	6	4	4	-	4
651°F - 725°F	6	6	6	4	6
726°F - 825°F	8	8	8	6	8
826°F - 925°F	10	8	8	6	8
926°F - 1000°F	10	10	10	8	10

### NOTES

1. Surrounding air temperature is assumed to be 70°F. For every degree over 100°F of the surrounding air, deduct 2 degrees from the maximum temperature ranges shown under the Pipeline fluid temperature column. (Example: 125°F) external temperature reduces maximum temperature values under the Pipeline fluid temperature column to 163, 210, 265, 315, etc.)
2. Valves may be insulated or uninsulated.
3. Brackets may be open rectangular tubes or the standard closed Keystone tubular shaft extensions.
4. All actuators have a maximum service temperature (outside atmosphere). These temperature limitations apply regardless of K-LOK extension lengths.

### VACUUM RATING

The combination of interference fit seats and bi-directional packing makes the K-LOK especially well suited for vacuum service.

Standard K-LOK high performance valves are rated to an absolute pressure of  $1.016 \times 10^{-3}$  mm Hg. Higher vacuum applications are available.

### C<sub>v</sub> VALUES VS. TRAVEL POSITION

Size NPS	Angle of opening								ASME 150 90°	ASME 300 90°
	10°	20°	30°	40°	50°	60°	70°	80°		
2	6	10	19	34	51	78	105	134	163	160
2½	6	10	19	34	53	80	111	148	175	170
3	8	12	24	43	67	100	139	186	220	215
4	16	13	44	80	130	194	269	360	425	413
5	30	44	83	149	242	366	504	673	795	785
6	50	70	130	230	370	550	760	1010	1195	1140
8	83	117	251	437	695	1052	1496	2001	2440	2300
10	144	202	454	754	1185	1821	2611	3541	4540	4333
12	208	304	678	1051	1625	2766	3838	5325	6915	6600
14	257	360	747	1186	1909	3121	4416	6225	8300	7920
16	308	432	803	1422	2289	3614	5251	7530	10040	9580
18	373	548	1121	1869	2990	4735	6728	9845	12460	11890
20	463	680	1390	2315	4010	6175	8795	12655	15430	14720
24	650	991	2076	3803	6060	9091	13301	18466	21660	20665

### NOTES

C<sub>v</sub> is the volume of water in US GPM that will pass through a valve with a pressure drop of 1 psi at 60°F.

# KEYSTONE SERIES 36 AND 37 K-LOK HIGH PERFORMANCE BUTTERFLY VALVES

## SEATING AND UN-SEATING TORQUE

Seating and un-seating torques are a function of the size of the valve and the shutoff pressure of the system.

Specific torque ratings can be found in the seating/un-seating chart at the intersection of the 'size' row and the 'shutoff pressure' column.

Torques listed are for PTFE and RTFE seated valves. For different seat materials, specific multipliers are to be used as stated.

All torques listed are for normal service conditions (i.e. operating frequency is a minimum of once per month; disc corrosion is expected to be mild or minor, the media is a clean gas, liquid or steam, and is non-abrasive) and chemical effects upon the seat are minor.

### PTFE AND RTFE BI-DIRECTIONAL SEATING AND UN-SEATING TORQUE VALUES (Metric)

Size DN	Mounting code		Seating and un-seating torque (Nm)					
	ASME 150	ASME 300	System shutoff pressure (bar)					
			10	14	20	28	35	50
50	BAB	BAB	25	32	43	52	59	66
65	BAB	BAB	25	32	43	52	59	66
80	BAC	BAC	28	36	49	59	67	73
100	BAD	BAD	54	68	93	112	127	140
125	BAD	BAD	105	127	153	177	198	215
150	CAD/CAE*	CAE	155	181	209	243	270	328
200	CAF	CAF	233	263	362	454	550	759
250	CAF/CAG*	CAG	377	412	531	706	842	1113
300	DAG	DAG	519	593	723	922	1095	1462
350	DAH	DAJ	763	854	1034	1294	1503	1944
400	DAH	DAK	1057	1181	1424	1695	1978	2509
450	DAJ	DBA	1345	1503	1785	2204	2475	3221
500	DAK	LAX	1763	1978	2373	2848	3243	4084
600	DAK	MAY	2452	2863	3458	4170	4757	6102

### PTFE AND RTFE BI-DIRECTIONAL SEATING AND UN-SEATING TORQUE VALUES (Imperial)

Size NPS	Mounting code		Seating and un-seating torque (lbs in)					
	ASME 150	ASME 300	System shutoff pressure (psig)					
			150	200	285	400	500	740
2	BAB	BAB	220	280	380	460	520	580
2½	BAB	BAB	220	280	380	460	520	580
3	BAC	BAC	250	320	430	520	590	650
4	BAD	BAD	475	600	820	995	1120	1235
5	BAD	BAD	925	1125	1350	1570	1750	1900
6	CAD/CAE*	CAE	1370	1600	1850	2150	2390	2900
8	CAF	CAF	2060	2330	3200	4020	4870	6720
10	CAF/CAG*	CAG	3340	3650	4700	6250	7450	9850
12	DAG	DAG	4590	5250	6400	8160	9690	12940
14	DAH	DAJ	6750	7560	9150	11450	13300	17200
16	DAH	DAK	9350	10450	12600	15000	17500	22200
18	DAJ	DBA	11900	13300	15800	19500	21900	28500
20	DAK	LAX	15600	17500	21000	25200	28700	36140
24	DAK	MAY	21700	25340	30600	36900	42100	54000

\* CAE and CAG mounting codes apply for shaft mounting of UHMWPE seats.

## NOTES

- Torques are applicable only to PTFE and RTFE seats in noncorrosive or non-abrasive services such as water.
- For other seat materials, select the torque applicable for the maximum differential pressure and multiply by the following factor:  
 EPDM/NBR/Fluoroelastomer (FKM): x 1.4  
 UHMWPE (clean service): x 1.3
- For corrosive, abrasive or other services than water, multiply by the following factor:  
 High solids slurry: x 1.5  
 Dry gas: x 2.0  
 Dry powders: x 2.7  
 Liquids other than water: x 1.2  
 Lubricating fluids: x 0.8  
 For services that combine unfriendly conditions such as extreme temperatures and high solids, or corrosive with high temperatures, contact your sales representative.

# KEYSTONE SERIES 36 AND 37 K-LOK HIGH PERFORMANCE BUTTERFLY VALVES

## METRIC DATA

### PRESSURE/TEMPERATURE RATINGS FOR BODIES, DISCS AND SEATS

Pressure (bar)	Temperature (°C)															
	-40*	-29	-18	38	82	93	121	149	204	232	260	316	371	425	482	538
<b>ASME Class 150 body (Series 36)</b>																
Carbon steel	N/A	19.6	19.6	19.6	18.2	17.9	16.9	15.8	13.7	12.7	11.7	9.6	7.6	5.5	N/A	N/A
Stainless steel	19.0	19	19	19	17	16.5	15.6	14.8	13.6	12.7	11.7	9.6	7.6	5.5	3.4	1.4
<b>ASME Class 300 body (Series 37)</b>																
Carbon steel	N/A	51.1	51.1	51.1	47.9	47.1	46	45.1	44.8	43.1	41.5	39.1	36.6	28.8	N/A	N/A
Stainless steel	49.6	49.6	49.6	49.6	44.3	43	40.4	38.1	35.5	34.2	33	31.2	30	29.1	28.6	25.2
<b>ASME Class 150 disc</b>																
Stainless steel	19.0	19	19	19	17	16.5	15.6	14.8	13.6	12.7	11.7	9.6	7.6	5.5	3.4	1.4
Monel	15.9	15.9	15.9	15.9	14.4	14	13.4	12.9	12.5	12.2	11.7	9.6	7.6	5.5	N/A	N/A
<b>ASME Class 300 disc</b>																
Stainless steel	49.6	49.6	49.6	49.6	44.3	43	40.4	38.1	35.5	34.2	33	31.2	30	29.1	28.6	25.2
Monel	41.4	41.4	41.4	41.4	37.4	36.5	35	33.7	32.7	32.6	32.6	32.6	32.4	31.6	N/A	N/A
<b>K-LOK seats</b>																
	NOTE: Seats ratings are independent from Body Ratings															
Teflon (TFE)	51.1	51.1	51.1	51.1	41.1	39	31	22.4	3.4	N/A	N/A	N/A	N/A	N/A	N/A	N/A
Reinforced TFE (RTFE)	51.1	51.1	51.1	51.1	48.3	46.9	37.9	31	15.5	6.9	3.4	N/A	N/A	N/A	N/A	N/A
UHMWPE	51.1	51.1	51.1	51.1	39.6	38.3	N/A	N/A	N/A	N/A	N/A	N/A	N/A	N/A	N/A	N/A
NBR	N/A	N/A	51.1	51.1	43.1	N/A	N/A	N/A	N/A	N/A	N/A	N/A	N/A	N/A	N/A	N/A
EPDM	51.1	51.1	51.1	51.1	47.9	47.1	37.9	N/A	N/A	N/A	N/A	N/A	N/A	N/A	N/A	N/A

### NOTES

\* -29°C is the limit for the scope of ASME B16.34

### PRESSURE/TEMPERATURE RATINGS FOR SEAT MATERIALS

#### ELASTOMER SEATS

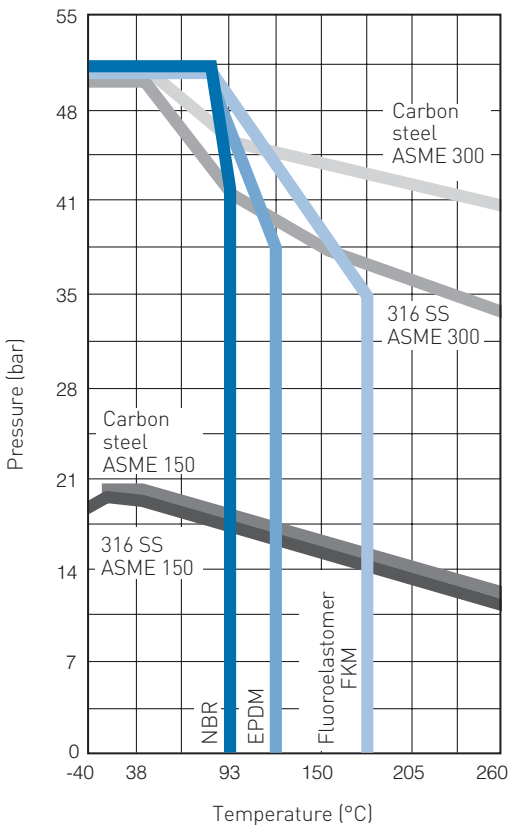

#### POLYMER SEATS

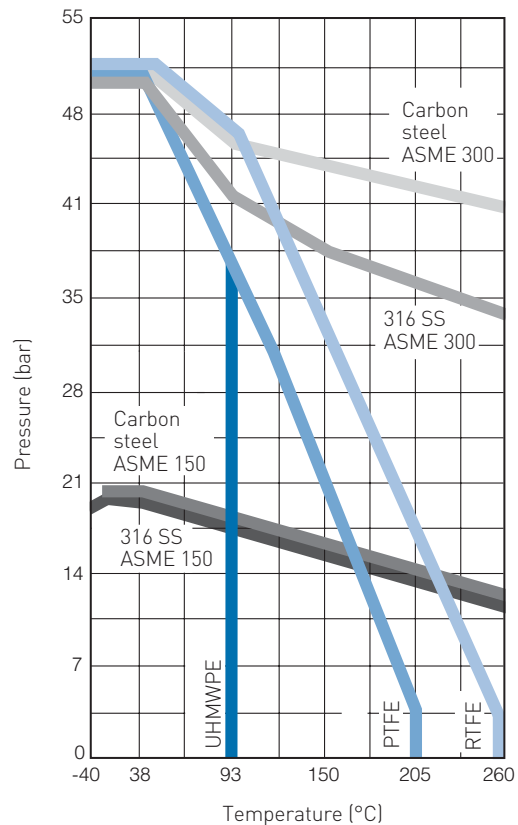

# KEYSTONE SERIES 36 AND 37 K-LOK HIGH PERFORMANCE BUTTERFLY VALVES

## IMPERIAL DATA

### PRESSURE/TEMPERATURE RATINGS FOR BODIES, DISCS AND SEATS

Pressure (bar)	Temperature (°F)															
	-40*	-20	0	100	180	200	250	300	400	450	500	600	700	800	900	1000
<b>ASME Class 150 body (Series 36)</b>																
Carbon steel	N/A	285	285	285	265	260	245	230	200	185	170	140	110	80	NA	NA
Stainless steel	275	275	275	275	243	235	225	215	195	183	170	140	110	80	50	20
<b>ASME Class 300 body (Series 37)</b>																
Carbon steel	N/A	740	740	740	692	680	668	655	635	620	605	570	530	NA	NA	NA
Stainless steel	720	720	720	720	640	620	590	560	515	498	480	450	435	420	415	365
<b>ASME Class 150 disc</b>																
Stainless steel	275	275	275	275	243	235	225	215	195	183	170	140	110	80	50	20
Monel	230	230	230	230	206	200	195	190	180	175	170	140	110	80	NA	NA
<b>ASME Class 300 disc</b>																
Stainless steel	720	720	720	720	640	620	590	560	515	498	480	450	435	420	415	365
Monel	600	600	600	600	540	525	508	490	475	475	475	475	470	460	N/A	N/A
<b>K-LOK seats</b>																
	NOTE: Seats ratings are independent of Body Ratings															
Teflon (TFE)	740	740	740	740	600	565	450	325	50	N/A	N/A	N/A	N/A	N/A	N/A	N/A
Reinforced TFE (RTFE)	740	740	740	740	692	680	550	450	225	100	50	N/A	N/A	N/A	N/A	N/A
UHMWPE	740	740	740	740	575	555	N/A	N/A	N/A	N/A	N/A	N/A	N/A	N/A	N/A	N/A
NBR	740	740	740	625	N/A	N/A	N/A	N/A	N/A	N/A	N/A	N/A	N/A	N/A	N/A	N/A
EPDM	740	740	740	740	692	680	550	N/A	N/A	N/A	N/A	N/A	N/A	N/A	N/A	N/A

### NOTES

\* -20°F is the limit for the scope of ASME B16.34

### PRESSURE/TEMPERATURE RATINGS FOR SEAT MATERIALS

#### ELASTOMER SEATS

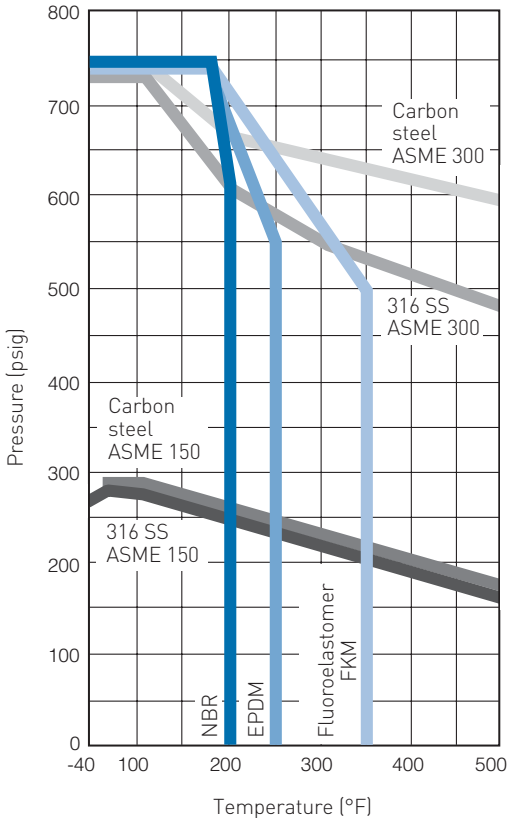

#### POLYMER SEATS

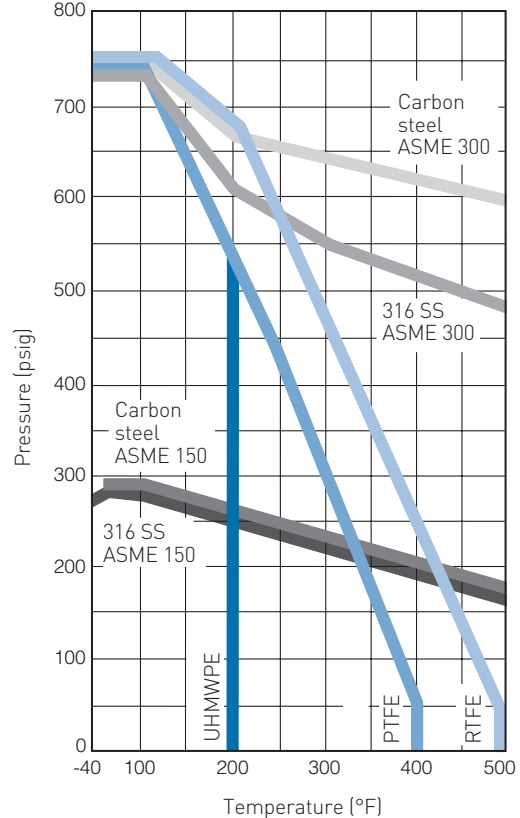

# KEYSTONE SERIES 36 AND 37 K-LOK HIGH PERFORMANCE BUTTERFLY VALVES

## SELECTION GUIDE

Example:	100	36	2	C	S	S	1	T	S	G	0	N
DN 100 (NPS 4) 150 ASME lug style carbon steel body, SS disc, 17-4 PH SS shaft, RTFE seat, bare shaft, NACE												
<b>100 362 CSS1TSG 0 N</b>												
<b>Size DN (NPS)</b>												
<b>50 (2)</b>	<b>125 (5)</b>	<b>300 (12)</b>	<b>500 (20)</b>									
<b>65 (2.5)</b>	<b>150 (6)</b>	<b>350 (14)</b>	<b>600 (24)</b>									
<b>80 (3)</b>	<b>200 (8)</b>	<b>400 (16)</b>										
<b>100 (4)</b>	<b>250 (10)</b>	<b>450 (18)</b>										
<b>Series</b>												
<b>36</b>	150 ASME											
<b>37</b>	300 ASME											
<b>Body style</b>												
<b>0</b>	Wafer											
<b>2</b>	Lug <sup>(1)</sup>											
<b>F</b>	Double flanged <sup>(1)</sup>											
<b>Body material</b>												
<b>C</b>	Carbon steel			<b>D</b>	Duplex 2205		<b>E</b>	Duplex 2507				
<b>S</b>	316 stainless steel			<b>X</b>	Other							
<b>Disc material</b>												
<b>S</b>	316 stainless steel			<b>D</b>	Duplex 2205		<b>F</b>	Duplex 2507				
<b>E</b>	316/SS/ENP			<b>X</b>	Other							
<b>Shaft</b>												
<b>S</b>	17-4 PH SS			<b>M</b>	K-500 Monel®		<b>D</b>	Duplex 2205		<b>E</b>	Duplex 2507	
<b>P</b>	316 stainless steel <sup>(2)</sup>			<b>N</b>	Nitronic® 50		<b>X</b>	Other				
<b>Seat material</b>												
<b>1</b>	RTFE/SS			<b>6</b>	UHMWPE <sup>(3)</sup> /Phenolic		<b>9</b>	Fluoroelastomer (FKM)				
<b>2</b>	RTFE/Phenolic			<b>7</b>	NBR		<b>X</b>	Other				
<b>3</b>	PTFE/SS			<b>8</b>	EPDM							
<b>Packing material</b>												
<b>T</b>	PTFE											
<b>G</b>	Graphite											
<b>Bearings</b>												
<b>S</b>	SS/TFE/BRZ			<b>U</b>	SS/Nitrided							
<b>R</b>	RTFE/composite											
<b>Body gaskets<sup>(4)</sup></b>												
<b>G</b>	Graphite (standard)			<b>P</b>	PTFE							
<b>F</b>	Fiber (optional)			<b>N</b>	None							
<b>Actuation</b>												
<b>0</b>	None			<b>2</b>	Gear		<b>4</b>	Pneumatic DA		<b>6</b>	Electric	
<b>1</b>	10 pos handle			<b>3</b>	Chainwheel		<b>5</b>	Pneumatic SR				
<b>Special</b>												
<b>N</b>	NACE			<b>C</b>	Oxygen clean		<b>NSF</b>	NSF/ANSI standard 61 tagging		<b>X</b>	Other	
<b>L</b>	Chlorine cleaning			<b>P</b>	PED/CE		<b>B7</b>	B7 bolting				

## NOTES

1. All lug and double flange valves have bolted seat retainers for full rated bi-directional dead end service.
2. 316 SS shafts are de-rated in some sizes and pressures. Consult factory.
3. UHMWPE seats must use ENP coated disc.
4. Standard body gasket is graphite. Fiber is provided for special applications. Consult factory.





Neither Emerson, Emerson Automation Solutions, nor any of their affiliated entities assumes responsibility for the selection, use or maintenance of any product. Responsibility for proper selection, use, and maintenance of any product remains solely with the purchaser and end user.

Keystone is a mark owned by one of the companies in the Emerson Automation Solutions business unit of Emerson Electric Co. Emerson Automation Solutions, Emerson and the Emerson logo are trademarks and service marks of Emerson Electric Co. All other marks are the property of their respective owners.

The contents of this publication are presented for informational purposes only, and while every effort has been made to ensure their accuracy, they are not to be construed as warranties or guarantees, express or implied, regarding the products or services described herein or their use or applicability. All sales are governed by our terms and conditions, which are available upon request. We reserve the right to modify or improve the designs or specifications of such products at any time without notice.

[Emerson.com/FinalControl](https://www.emerson.com/FinalControl)

---