



Reliable Valve Automation is Critical to Delayed Coker Efficiency

Benny Deters,
Calabrian Corporation

and

Ross Wolkart,
Emerson Process Management

The Process

A Refinery's delayed coking unit is not new technology, but is the most common process to upgrade the residual hydrocarbons remaining after upstream processing to remove water and soluble salts in the crude desalter; production of gasoline, diesel, jet fuel and atmospheric reduced crude through atmospheric distillation; and the production of heavy vacuum gas oil (HVGO) during vacuum distillation. The vacuum reduced crude remaining after these three stages becomes the principal feedstock for the next process stage – delayed coking.

The residual liquid product is pumped into the bottom of a fractionation column where it mixes with recycle vapors to become preheated. The mixture then enters a tube furnace and heats to approximately 900°F (480°C) outlet temperature. As the product enters the bottom of a coking drum from the furnace, thermal cracking occurs and the lighter gas oil is vaporized with steam injection and separated, flowing back to the

fractionators. The heavier, porous solids, the petroleum coke, remain in the vertically suspended drum, a mammoth cylindrical structure often as much as 30 feet diameter and 80–100 feet in length. The coke builds up inside the coking drum over a period of 10–12 hours to a pre-determined level, when the flow is switched from the furnace to a reserve drum through a three-way automated ball valve. The operating drum then goes off line, is steamed to lower the coke's hydrocarbon content, water quenched to reduce the drum temperature, and prepared to have its coke removed by high pressure water drilling and cutting methods during a 4–6 hour window. Once the coke is cut from the drum, it is transported for use as a fuel source in coal-fired power plants or further calcined in an adjacent operation to remove additional impurities and ultimately be used in higher end applications and fuels sources for steel making and anodes in aluminum production. The process repeats itself as the decoked drum is washed, closed and preheated to again accept product after the reserve drum fills.

While refinery operations are continuous, the delayed coker is a batch process, producing its end product in an active drum while the other is offline. The timing of coke production and

drum decoking is critical to the operation of the refinery. It provides finite storage of the petroleum coke. If there are mechanical breakdowns that impede the product flow through the drums, repairs or replacements need to be made within the decoking time window or else the entire refinery production could be backed up and necessitate an unscheduled shutdown, resulting in production losses of \$1 million per day or more.

Conditions in the Coker

Operations in any refinery's delayed coking unit are extremely severe, perhaps the harshest of any refinery operation. Inlet temperatures of the residual oil flowing from the fractionator through the transfer line into the coke drum exceed 800°F (425° C) at low pressures of 10–15 psig. As the operating drum fills with coke, torques on the valves wetted parts tend to increase, putting additional stress on the transfer line ball valve and added operational torque on the multi-turn electric valve actuator. During the coke removal process, there is extreme vibration. The high pressure water lines used to drill out and cut the coke from the drum internals create pressures to 4,000 psi. The steam and quench water piping is susceptible to rapid expansion and temperature fluctuations of condensate and/or

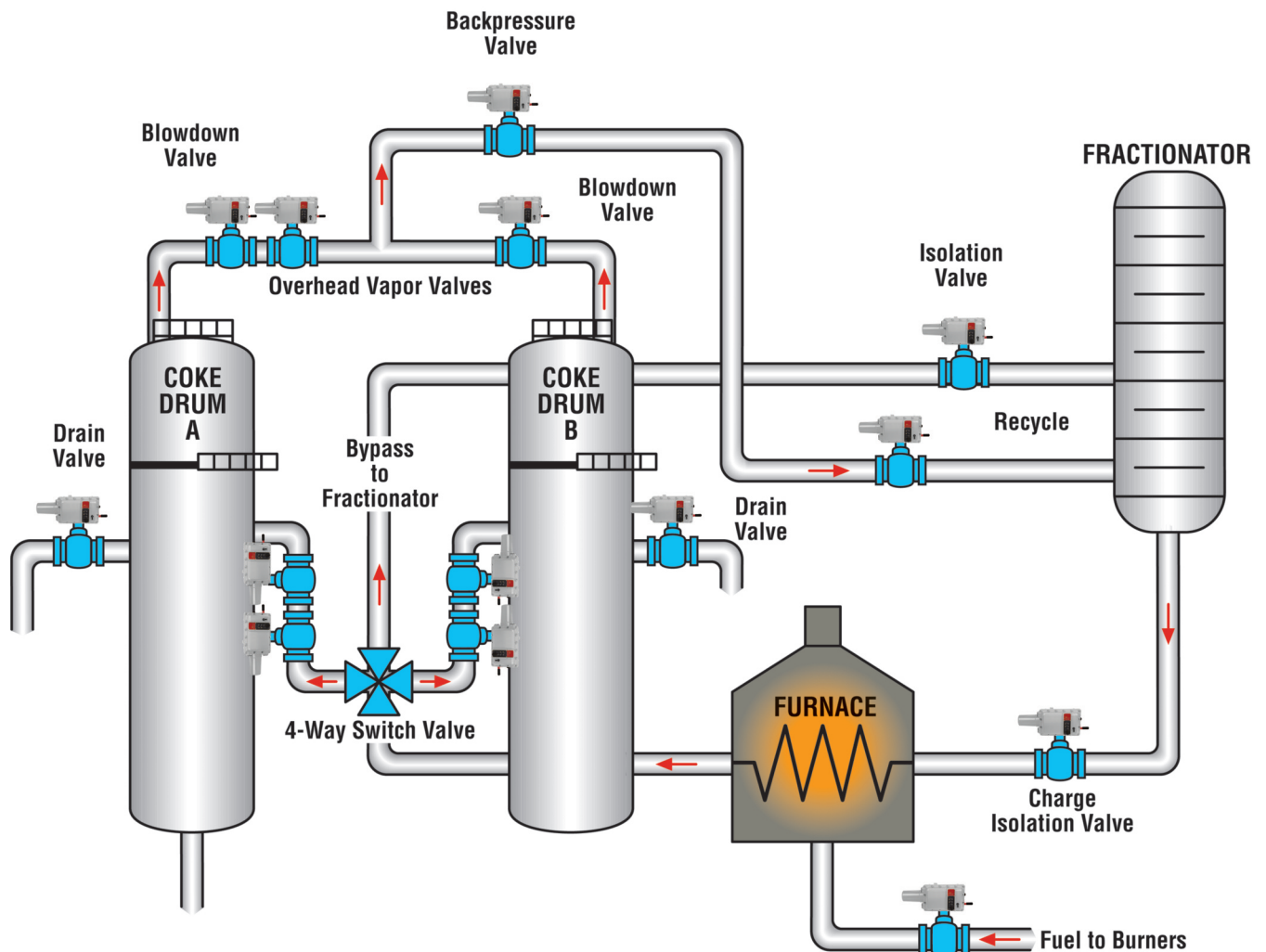

water, producing an often violent water hammer effect. Corrosion is present as the coke's traces of sulfur combine with the unit's wash down water. During the wash down phase, a significant amount of abrasive airborne dust is created, covering all surfaces within the drum and its immediate surrounds. The coke dust not only creates challenges for corrosion protection, but builds up in crevices, impeding instrument functionality. In addition to the harsh conditions, the area for equipment maintenance is confined, hot and potentially dangerous.

The impact on valves and actuators

Typically, there are 8 to 10 valves for each drum in the coking process on multiple service including recirculation, switching, quenching, wash down, steam hydrocarbon stripping and drum reheating steam. They are controlling piping that transports steam, water, slurry, hydrocarbons and product. The severe conditions of the coker operation often have a detrimental effect on these valves and the actuators operating them. Making it more critical is the fact that the valves must work on a schedule of sequential strokes to divert process in a precisely timed event.

Controlled by a programmable logic command, the valve's sequential event must be executed by an actuator consistently and reliably. They each have safety interlocks restricting their opening and closing through limit switches to maintain process control. An inoperable valve actuator must be reinstated quickly so that the system can continue functioning. If actuators fail, the valves have to be opened or closed manually, a strenuous and time consuming process for the unit operator, yet a necessity to keep the coking/decoking process in sequence and on schedule.

Automated valve performance and Mean Time Between Failure (MTBF) are constant and costly problems for the refinery. While valves are not as susceptible to failure and can generally be serviced during periodically scheduled

shutdowns, actuators have been prone to early failure or considerable repair.

During my refining career, I have experienced coker actuator failure almost immediately after installation and normal life expectancy between two months to a year. Actuator failure could be attributed to a variety of conditions. Water hammer and vibration effects have broken internal electrical connections and dislodged microprocessor components. Motors have become disconnected from the actuator housing through vibration and, when inspected, were found to be precariously hanging from their wires. Coke dust fines have penetrated the actuator housing, causing inoperability of electronic components, or caused on/off pushbuttons to become clogged and non-working. Corrosive elements have eroded aluminum actuator housings, wiring and even its external handwheel, the sole operational backup. Maintenance costs were excessive, with callout and overtime maintenance charges and even a full-time manufacturer's representative troubleshooter whose sole function was to keep the valves operating as scheduled or timely repaired.

A Successful Solution

The search for a robust actuator solution to provide extended service life resulted in testing and selecting a modification of an established design that had provided exceptional service in other demanding applications. While not the newest iteration of technology, it had been engineered to provide the necessary

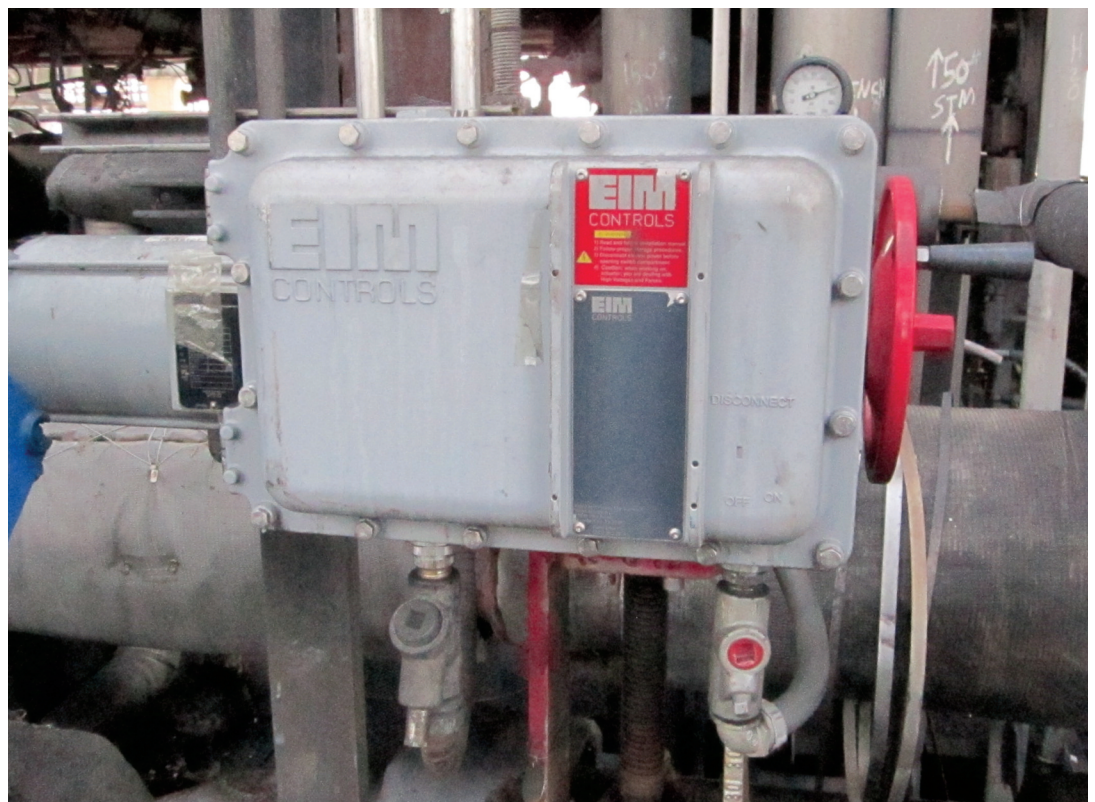

features for success in this demanding application. The selected unit used industrial grade epoxy coatings on all external surfaces as standard construction to provide excellent corrosion resistance. Also standard was its marine grade aluminum enclosure with stainless steel captured bolting. Unlike many newer and more sophisticated actuator designs, this solution had no microprocessor components. Rather it had incorporated reliable circuit boards with no termination wiring and compact internal limit switches and relays that could withstand the high temperature all actuators are exposed to in a delayed coking unit. The actuator could be remotely managed from a special hardwired push button panel unaffected by the dust, yet within sight of the actuator in order to verify proper operation. Internal control components were smaller, compact and lightweight to resist self-destruction from inertia and momentum generated from vibration and water hammer effects. Its linear drive train and gearbox assembly were configured to withstand high torque and thrust loads while maintaining alignment.

Sizing safety factors were also a consideration. For reliable operation, any actuator should be sized to provide a true 2X safety factor, accounting for the variable torques needed as the process progresses, piping expands and contracts, requiring higher torques not included in published new valve torque values. The overall actuator footprint and weight was sufficient for operation in tight spaces and accommodating a variety of valve installation positions.

The selected actuators, once tested and installed provided the refineries immediate relief from failure. They have now been in continuous service for more than six years in one Refinery and more than three years in another. There have been virtually no failures and maintenance can be completed during scheduled plant shutdowns.

Summary

The importance of valves and their electric actuators that control the operation in a delayed coker cannot be understated. As a batch process, the coker becomes the potential bottleneck in an otherwise continuous refining operation. If the critical coke drum filling, drum switching and decoking schedule gets significantly interrupted, it could impact the entire refinery throughput, costing the company millions of dollars/day in lost production. The valve actuator, seemingly a very small item in the total process, has a significant importance and a great impact on the delayed coking operation. Premature failure can lead to extra costs for operator overtime, additional manpower for manual valve operation, replacement costs and potential refinery downtime, not to mention the safety aspects of manual operation. A robust solution is a field-proven ductile iron-housed, powder-coated actuator with remote operation. Its compact physical size and weight, unique internal electric circuitry configuration and modified hard wire operation has provided refineries with considerable cost savings and has averted potential production curtailment.

Authors

***Benny Deters** is the Director of Manufacturing at Calabrian Corporation, a specialty chemical manufacturer in Port Neches, Texas. He is an electrical engineering graduate from McNeese State University. He has more than 25 years management experience in delayed coking and plant operations.*

***Ross Wolkart** is EIM gas and pneumatic product manager at Emerson Process Management Valve Automation. He is a graduate of Southeastern Louisiana University and has been the company's refining and pipeline application specialist, with more than 16 years sales and service experience and an expertise in delayed coking operations.*