

AMS ASSET MONITOR – HEAT EXCHANGER ADVISOR

Identify non-optimal operation caused by fouling, leakage or heat duty errors

Often described as the workhorse of the process industry, the shell and tube heat exchanger is an immensely versatile unit, able to handle a wide range of process applications and conditions. Whether you are looking to cool, heat, vaporize or condense, the shell and tube can meet your needs.

Maintaining the health and performance of this asset could be critical to maintaining your production schedule!

The AMS Asset Monitor is an edge analytics device that delivers the benefits of continuous monitoring to more plant assets and far less installation expense.

QUICK, EASY DEPLOYMENT AND USE

- Small footprint size that is easy to mount.
- Field-located close to the heat exchanger for easy and lower-cost wiring.
- Predefined asset templates eliminate costly engineering.
- Easy DIY configuration.
- Built-in web service software interface replaces software, server, and licensing.
- Access asset health with any browser-enabled device from anywhere.

AUTOMATED COLLECTION AND BUILT-IN EDGE ANALYTICS

- Continuous data collection eliminates data gaps between collections.
- Automated analysis provides current asset health 24/7.
- Vibration training and experience not required for diagnosis.

INTERFACE DATA TO OTHER SYSTEMS AND ANALYTICS

- Acts as Modbus TCP/IP Slave and OPC UA Server.
- Connects to AMS Optics Platform, Historians, PLC, DCS, and Data Lakes.

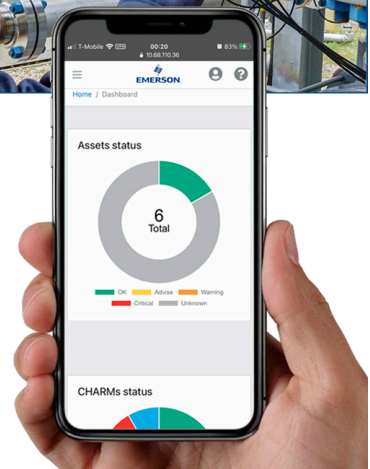
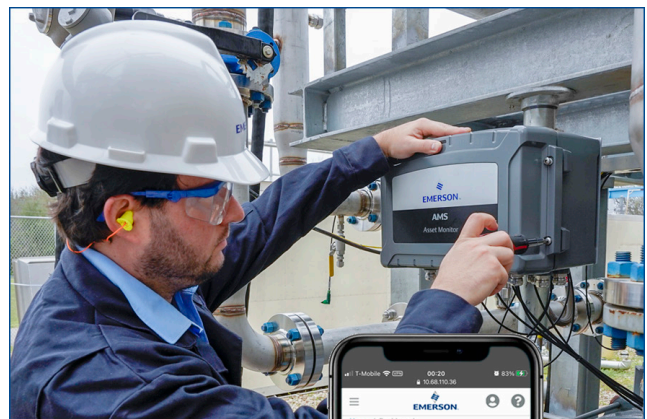
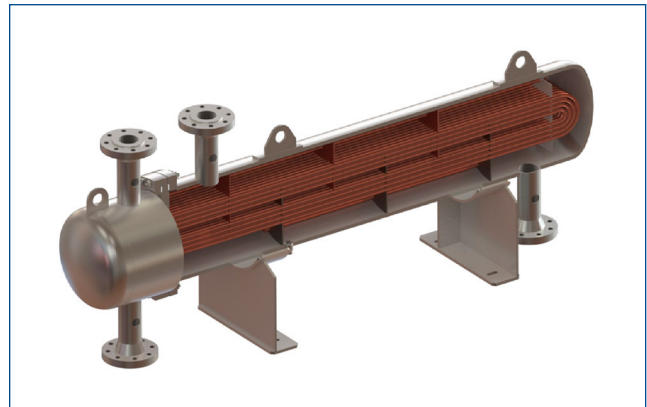

INTEGRATION WITH EMERSON'S DELTAV™ DCS

- Supports the new Module Type Packages (MTP) for DeltaV™, facilitating integration and communication between operations and field assets.
- Uses the same **Characterization Modules (CHARMs)** as DeltaV Remote for click-in-place technology.
- Similar housing to the DeltaV junction box for ruggedness and familiar installation.

AMS ASSET MONITOR – HEAT EXCHANGER ADVISOR

Intuitive Dashboard for Common Issues

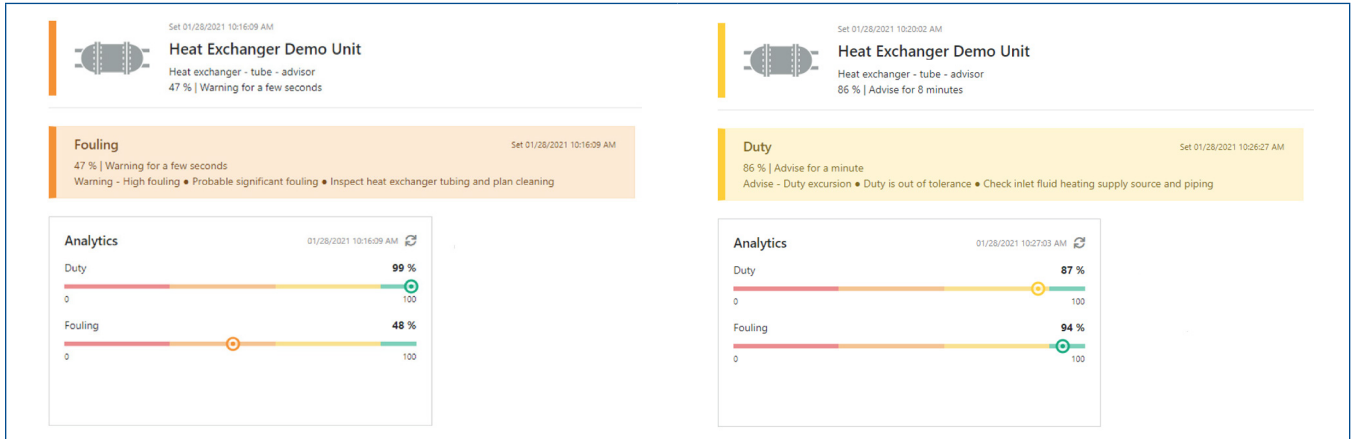

Typical heat exchanger issues include:

- Fouling, or the build-up of unwanted material on one or both sides of the asset. This increases wall thickness and impacts the effectiveness of heat transfer.
- Leaking as a result of a mechanical or welding break in the surface, or gasket failure. This can have environmental, safety and operational implications.
- Heat duty errors caused by inaccurate measurements or instrumentation failure.

Easy configuration includes:

1. Manual entry of general and asset-specific parameters such as:
 - Max Side Flow
 - Side Heat Capacity
 - Heat of Vaporization
 - Vapour Fraction Outlet
 - Vapour Fraction Inlet
 - Clean Exchanger Coefficient
 - Heat Transfer Area
2. Source Mapping for CHARMS.
3. External data points, such as mass flow.

HE1b
Type: Heat exchanger - tube - advisor Modified: 21.12.2020 10:16:59 Modified by: admin, admin

Source mapping
Map available sources to the measurement locations (MLs). The selection will determine Measurement alerts and Analytics.

ML	ID	Description	Source
1	HMFL	Hot side flow	CHM1-11 (CHM1-11) ✓
2	HMITMP	Hot side inlet temperature	CHM1-03 (CHM1-03) ✓
3	HHDP	Hot side dP	Hot side DP ✓
4	HHOTMP	Hot side outlet temperature	CHM1-10 (CHM1-10) ✓
5	HCFL	Cold side flow	Cold side flow ✓
6	HCTMP	Cold side inlet temperature	Cold side inlet temperature ✓
7	HCDP	Cold side dP	Cold side DP ✓
8	HCOOTMP	Cold side outlet temperature	Cold side outlet temperature ✓